

10010046

Received SEC

JAN 19 2010

Washington, DC 20549



A Tradition of Quality Since 1850

ANNUAL REPORT 2009

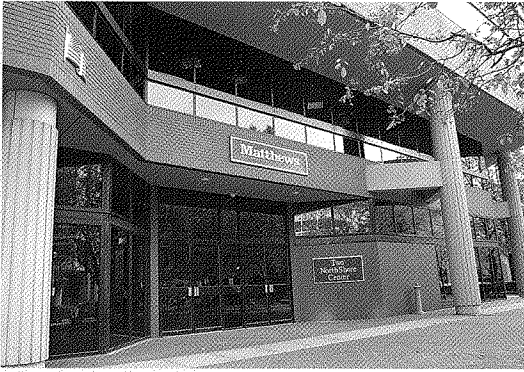

Matthews International Corporation

is comprised of two business groups,

Memorialization and Brand Solutions.

Through internal growth and strategic acquisitions, the Company has expanded its presence around the world, employing approximately 4,500 people worldwide.

International flags on front cover...

Matthews International Corporation conducts business in the nations represented by the flags printed on the front cover of this report.

From top to bottom, those nations are:

the United States, Australia, Austria, Canada, China, Denmark, France, Germany, Hong Kong, Italy, Mexico, Poland, Singapore, Spain, Sweden and the United Kingdom.

Corporate Office

Two NorthShore Center
Pittsburgh, Pennsylvania 15212-5851
Phone: (412) 442-8200 • Fax: (412) 442-8290
E-mail: investorrelations@matw.com
Company website: www.matw.com

Annual Meeting

Thursday, February 18, 2010 ~ 6:00 p.m.
Sheraton Station Square Hotel
300 West Station Square Drive
Pittsburgh, Pennsylvania 15219

Form 10-K

A copy of the Matthews International Corporation Annual Report to the Securities and Exchange Commission on Form 10-K is also available to shareholders on the Company's website.

Transfer Agent, Registrar & Dividend Disbursement Agent

Questions regarding stock certificates, replacement of lost certificates, address changes, account consolidation, and lost or misplaced dividends should be addressed to:

Computershare Investor Services LLC
P.O. Box 2388
Chicago, Illinois 60690-2388
Phone: (888) 294-8217 • Fax: (312) 601-4332
Internet: www.computershare.com

Inquiries

Matthews International Corporation welcomes and encourages questions and comments from its shareholders, potential investors, financial professionals, institutional investors and security analysts. Interested parties should contact Steven F. Nicola, Chief Financial Officer, Secretary and Treasurer, by mail or telephone at the Company's Corporate Office.

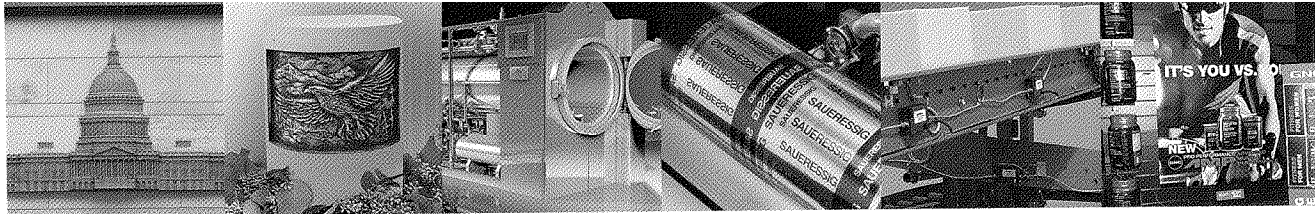

Company Profile

Matthews International Corporation, headquartered in Pittsburgh, Pennsylvania, is a designer, manufacturer and marketer principally of memorialization products and brand solutions. Memorialization products consist primarily of bronze memorials and other memorialization products, caskets and cremation equipment for the cemetery and funeral home industries. Brand solutions include graphics imaging products and services, marking products, and merchandising solutions. The Company's products and services include cast bronze memorials and other memorialization products; caskets; cast and etched architectural products; cremation equipment and cremation-related products; mausoleums; brand management,

printing plates and cylinders, pre-press services and imaging services for the primary packaging and corrugated industries; marking and coding equipment and consumables, and industrial automation products for identifying, tracking and conveying various consumer and industrial products, components and packaging containers; and merchandising display systems and marketing and design services.

Detailed financial information relating to business segments and to domestic and international operations is presented in Note 16 (Segment Information) to the Consolidated Financial Statements.

SEC Mail Processing
Section

JAN 19 2010

Financial Highlights
Washington, DC
110

Dollar amounts in thousands, except share data

	2009	2008	2007
Operating Results			
Sales	\$780,908	\$818,623	\$749,352
Operating profit	101,011	132,952	111,824
Income before income taxes	88,543	121,572	103,716
Net income	57,732	79,484	64,726
Per Common Share			
Diluted earnings per share	\$1.90	\$2.55	\$2.04
Dividends	.265	.245	.225
Financial Position			
Total assets	\$949,653	\$914,282	\$771,069
Long-term debt, noncurrent	237,530	219,124	142,273
Shareholders' equity	434,218	433,955	426,778

One of the best measures of a good company is its performance under difficult conditions. As we prepare this annual report on our operating results for fiscal 2009, we continue to be in the midst of tough economic times. While some market experts suggest that the U.S. economy is beginning to recover, we expect that such recovery will take some period of time. At present, the unemployment rate continues to be high and consumers remain conservative in their spending. As a result, many of the customers that we serve, both on the Memorialization and Brand Solutions sides of our business, remain conservative in their spending as well.

As shareholders, it is important for you to know that we have not stood still during this recession. As a company, we have historically worked hard to ensure that the cost structures of our businesses

are appropriately aligned with their respective revenue run rates. Because of the impact on sales from this economic downturn, we have taken some very difficult, but necessary actions during the past twelve months. All of our businesses have been affected to some degree by the economy, and all of our businesses have taken actions to mitigate, to the degree practical, its impact on profitability.

Matthews has been in business since 1850, and the success of our Company has been built on the long-term visions of our predecessors. As a public company, we continue to be mindful of the need to meet near-term results objectives, but we will not compromise our ability to develop and achieve our long-term goals.

Although the results for fiscal 2009 were not up to our Company's long-term expectations, it was still a reflection of the hard work and dedication of our

When I was first elected to the Board of Directors in 1981, Matthews was an employee-owned company with around 1,200 employees (650 of which were shareholders) and annual sales of approximately \$62 million. Our operations for the most part were in the United States and Canada. Today, we are a publicly-traded company with 4,500 employees around the world and annual sales of almost \$800 million (36% of which were outside the U.S.). It has been a tremendous experience for me to see this Company grow and to be a part of it.

Matthews has been fortunate to consistently have such a solid group of dedicated employees. Our people have been our greatest asset and have been the foundation of Matthews' success.

We have also been fortunate to have good leaders within Matthews, both past and present, enabling Matthews to adapt and prosper since 1850, even in difficult times like this past year. I am confident that your leaders today are laying the groundwork for continued growth and success. Although I will be retiring from the Board in February 2010, as a shareholder, I remain excited by the Company's initiatives and strategies.



William J. Stallkamp (L), Chairman of the Board of Directors, and Joseph C. Bartolacci, President and Chief Executive Officer

It has been my sincere privilege to be a part of this great organization. I want to take this opportunity to express my appreciation to the shareholders and employees of Matthews for your support during my 28 years as a director of the Company.

William J. Stallkamp
Chairman, Board of Directors

*In order to continue the success that our Company
has achieved over many years, we must continue to evolve.
Our markets are changing and we must adapt.*

employees. In addition to working through the impact of revenue declines caused by the recession, we challenged the management teams of each of our segments to scrutinize the long-term strategies of their businesses to ensure that Matthews continues in the right direction toward achieving its long-term growth objectives.

We also recognize that Matthews is in a period of transition in many of its businesses. In order to continue the success that our Company has achieved over many years, we must continue to evolve. Our markets are changing and we must adapt.

In fiscal 2009, our Memorialization businesses were adversely impacted by the recession as well as a decline in the casketed death rate. With respect to projected death rates in the future, we continue to evaluate the demographics of the U.S. market. Based on this analysis, we expect death rates to remain relatively flat in the near term and increase over the long term. We also expect, however, that the growing cremation trend will likely absorb most of this long-term increase. As a result, we project casketed and in-ground burial death rates to be relatively flat long term as well.

As such, we need to develop long-term strategies and adapt our businesses accordingly. In this regard, it is important that we continue to emphasize and promote memorialization. Almost everybody has a desire to be memorialized, recognized and remembered, whether it is a memorial to pay tribute to a person's life, or a plaque to recognize an accomplishment or an event. It is part of our culture. In addition, we will look for opportunities to expand our presence in the growing cremation market. We believe this market provides growth opportunities for Matthews both in the U.S. and overseas. We also have been evaluating the introduction of new product offerings in the memorialization market.

The recession was also the main factor influencing the fiscal 2009 results of our Brand Solutions businesses. These businesses are more economically sensitive as our

customer base includes consumer products companies, retailers and industrial companies. Looking forward, we expect each of these businesses to improve as the economy recovers. We have taken actions in our U.S. and European operations to reduce our cost of doing business, which should place us in a better position for recovery. In addition, we continue to work on strategies to grow each of these businesses longer-term. These strategies include new product development, expansion of our presence geographically, and broadening our product and service offerings.

Fiscal Year 2010 and Beyond

As I stated earlier, one of the best measures of a good company is its performance under difficult conditions. I believe that the fiscal 2009 performance of Matthews during these tough economic times clearly demonstrates the stability of our Company and the strength of our employees. Excluding unusual items, we posted one of the most profitable years in the Company's history. This could not be accomplished without the hard work and dedication of many people. Further, it is certainly fair to say that, in many respects, the fiscal 2009 efforts and performance of our people may have been the best in the Company's history. I am extremely proud to be a part of this organization and, based on the efforts placed in our strategic planning initiatives, look forward to a successful future.



Joseph C. Bartolacci

President and Chief Executive Officer

- Despite the economic downturn, the Company generated operating cash flow in excess of \$90 million in fiscal 2009.
- During fiscal 2009, we repurchased 796,916 shares of our common stock. The buy-back program is designed to increase shareholder value and add to earnings per share.
- For the quarter ended September 30, 2009, the Board of Directors increased the Company's quarterly cash dividend to \$.07 per share. This was Matthews' fifteenth dividend increase since our initial public offering in July 1994.
- Sales of \$282 million (or 36% of total sales) were generated outside of the United States in fiscal 2009.

Percentage of the Company's Fiscal 2009 Consolidated Sales

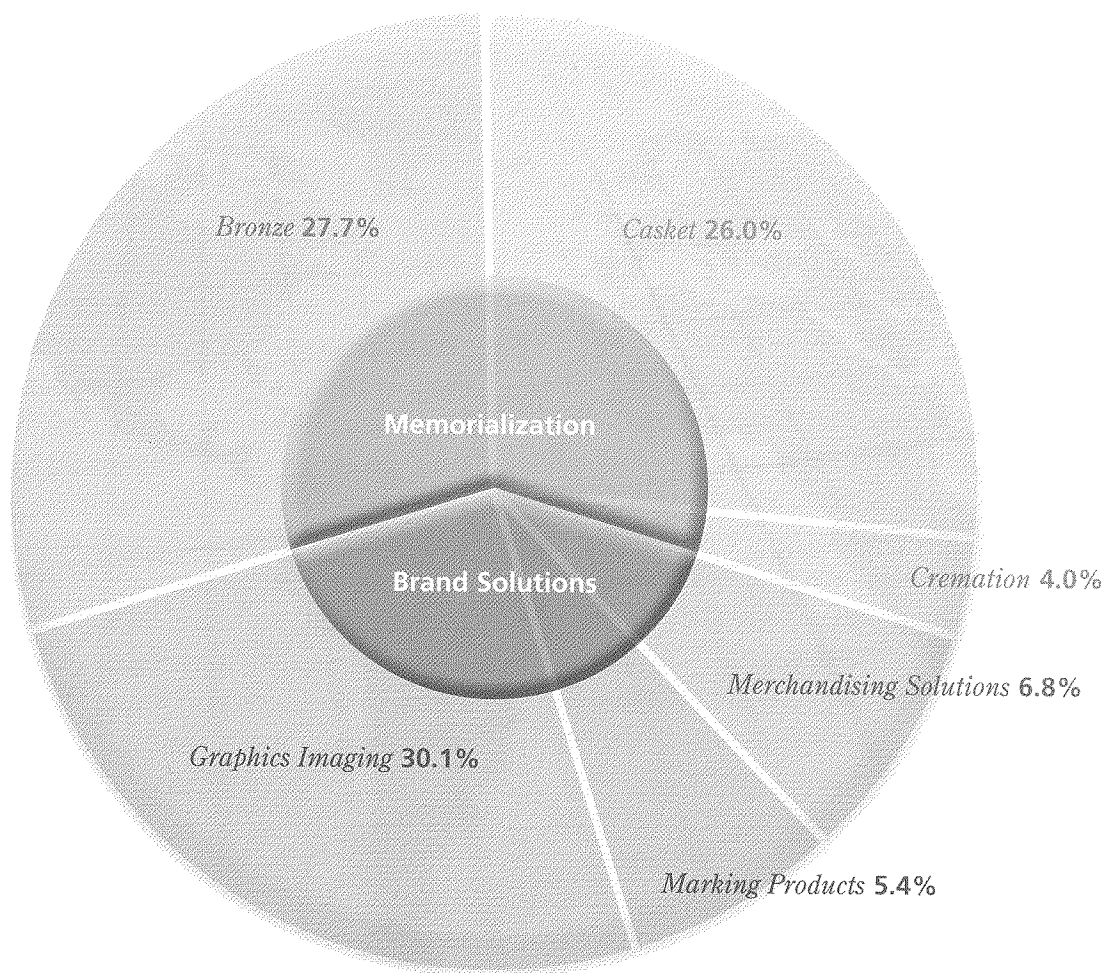

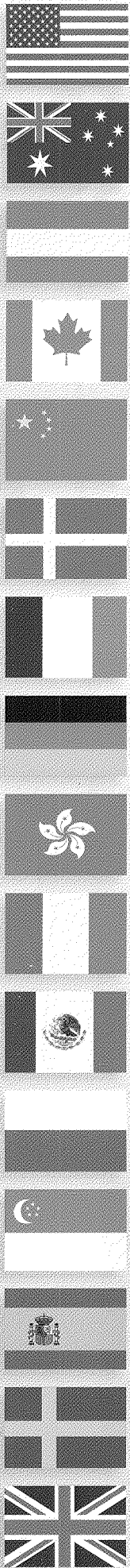

M e m o r i a l i z a t i o n

The three segments of the **Memorialization Group** of Matthews International are:

■ **Bronze** ■ **Casket** and ■ **Cremation**

These segments' products include cast bronze memorials and other memorialization products; caskets; cast and etched architectural products; cremation equipment and cremation-related products; and mausoleums.

Bronze

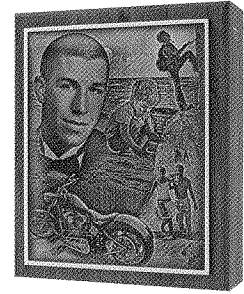

B



A

(A) Capitol Visitor Center Signage – Two 15-foot-long x 7-foot-high sculpted, aluminum castings of the Capitol Building with identifying letters were manufactured for the United States Capitol Building's new visitor center in Washington, D.C.

(B) Remembrance Portraits / Urns – Lasting Memories® Remembrance Portraits, a natural progression from the photographic memory boards often displayed during a funeral service, can also be attached to a wood urn to create a highly personalized tribute.

(C) Flush Bronze Memorials can be personalized with different border styles as well as epitaphs, emblems and sculpted or ceramic portraits. Every Matthews memorial is finished with the Company's patented Diamond Shield® protective coating to preserve the natural beauty of the bronze.

(D) Full Color Family Estates – Matthews' Granite Cremation Estate Bench can now be enhanced with full color memorial tributes and features.

(E) Community Chapel Mausoleum – A two-story mausoleum was constructed by Matthews' Gibraltar Mausoleum Construction Company for Woodruff Memorial Park in Canonsburg, PA. The mausoleum includes over 1000 interior and exterior crypts and a library of 700 niches.

The Bronze segment manufactures and markets products in North America, Europe and Australia used in the cemetery, funeral home and architectural industries. The segment's principal products include cast bronze memorials and other memorialization products used mainly in cemeteries. Memorial products include flush bronze memorials, flower vases, crypt plates and letters, cameo portraits, cremation urns, niche units, cemetery features and statues, community and family mausoleums, and granite monuments and benches. In addition, the segment manufactures and markets cast bronze and aluminum architectural products used to identify or commemorate people, places, events and accomplishments. ■

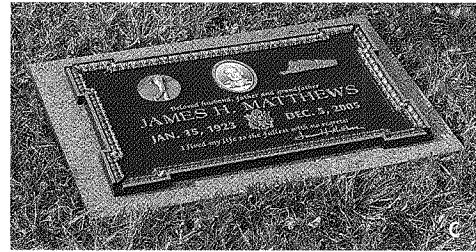

C

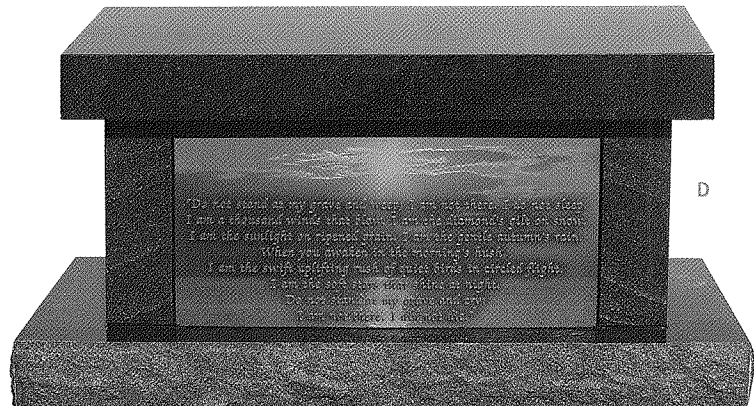

D



E

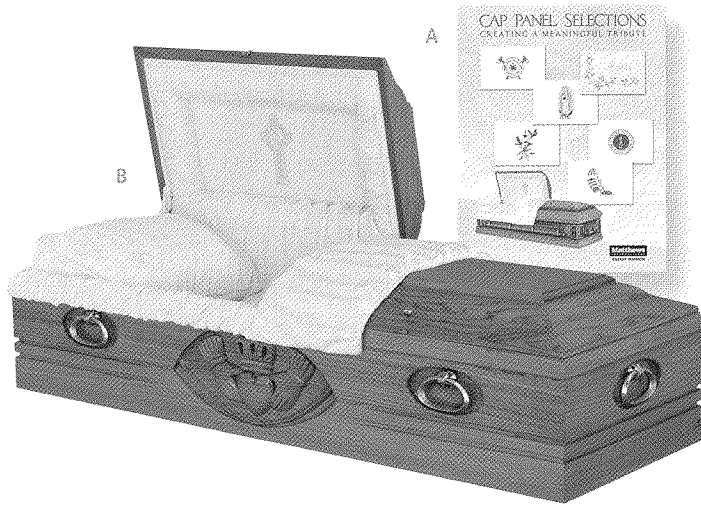

The Casket segment is a leading manufacturer and distributor of caskets in North America, producing a wide variety of wood and metal caskets. It is also a leader in providing assortment planning and merchandising and display products for funeral service businesses. These products assist funeral service professionals in providing value and satisfaction to their client families. ■

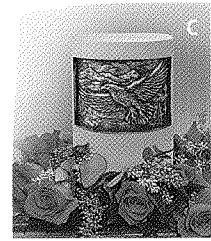

(A) Cap Panel Catalog – A new cap panel catalog was recently introduced, consolidating three panel programs into one while providing funeral homes and families with many classic choices for honoring the memory of a loved one in a personal way.

(B) Shannon Casket – Matthews and Irish-owned Heritage Casket recently formed a business alliance to bring the finest European-made funeral products to American funeral homes and their client families. The Shannon Cherry casket features a Celtic Cross cap panel.

(C) Solitude Urn – A new urn catalog was introduced by the Memorialization Group showcasing a variety of urns, keepsakes and jewelry.

(D) Sierra Casket – The economical 18-gauge steel Sierra casket collection provides high eye appeal in four popular two-tone finish combinations.

(E) Portable Catalog – New for 2009, the Matthews Portable Catalog is a user-friendly catalog on disc that allows a funeral home or family to personalize a “virtual casket” by visualizing many combinations of cap panels and corner art.

(F) IMS® – Matthews, in conjunction with FrontRunner Pro, released version 4.0 of its cutting-edge IMS® (Integrated Management System), adding multiple new features to benefit Funeral Directors and their client families.

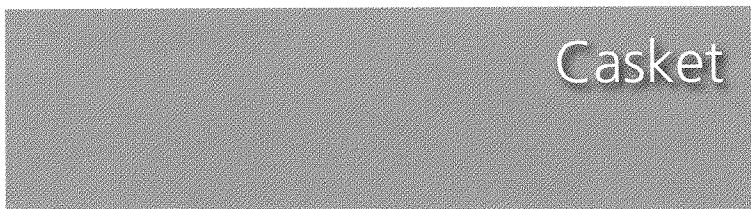
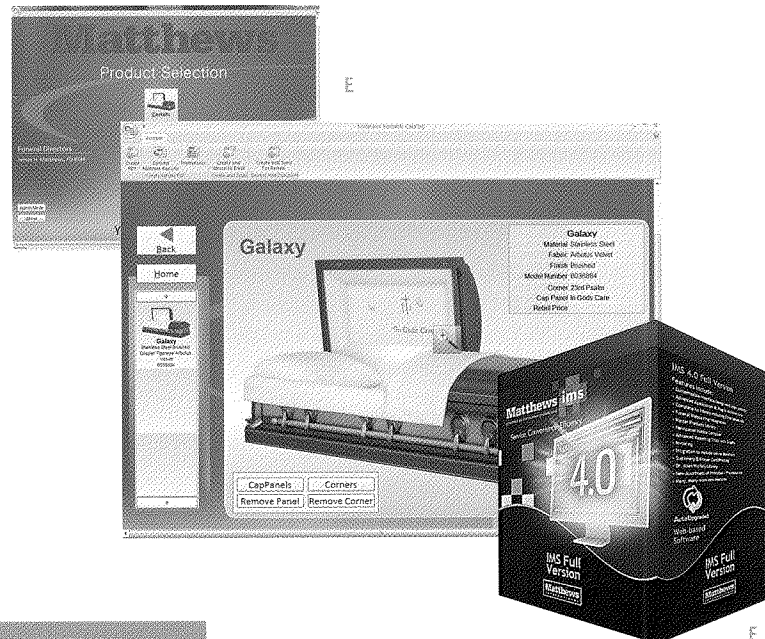

Cremation

The Cremation segment is the leading designer and manufacturer of cremation equipment and cremation-related products in North America. Cremation equipment and products are sold primarily to funeral homes, cemeteries, crematories, animal disposers and veterinarians within North America, Europe, Australia and Asia. The segment also manufactures environmentally-friendly caskets, which are manufactured from wood fibers and corrugated materials covered with cloth, or paper veneer, which gives the appearance of wood. ■

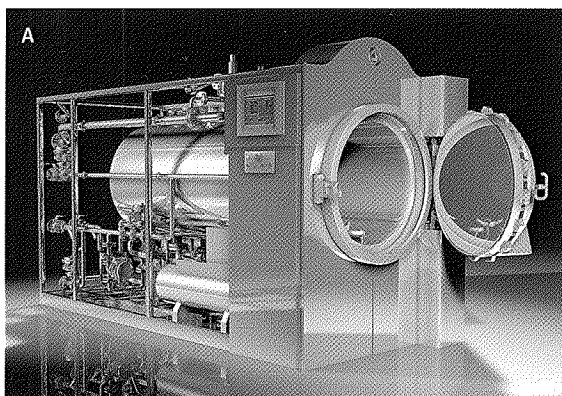

(A) Bio-Cremation is a water-based (versus flame-based) cremation process that significantly reduces emissions from the cremation process. This technology will allow the installation of cremation systems in areas previously not possible, especially the more densely populated areas where cremation demand is growing.



(B) The SecurIDy™ Cremation Tracking System provides cremation facilities with an added level of security and assurance in maintaining proper identification of human remains in their care awaiting cremation processing. The SecurIDy™ system also incorporates an extensive crematory operations management component that captures information and provides client defined reports, forms and certificates.

(C) The CRM6 Cremation System combines the esthetic qualities desired in many new crematories with the highest level of environmental controls and performance required anywhere in the world. These systems are designed and configured to meet existing or new building requirements and local cultural needs.

(D) Emerick Paper Veneer Casket – Cremation caskets continue to evolve into more environmentally friendly designs. This cutting edge design utilizes mostly cardboard substrates with a rich paper veneer to give the appearance of solid wood... a great appearance without the level of carbon emissions that result from cremating traditional wood products.



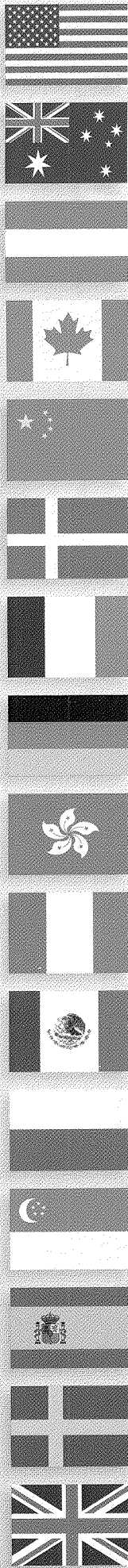

B r a n d S o l u t i o n s

The three segments of the **Brand Solutions Group** of Matthews International are:

■ **Graphics Imaging** ■ **Marking Products**
and ■ **Merchandising Solutions**

These segments' products and services include brand management, printing plates and cylinders, pre-press services and imaging services for the primary packaging and corrugated industries; marking and coding equipment and consumables, and industrial automation products for identifying, tracking and conveying various consumer and industrial products, components and packaging containers; and merchandising display systems and marketing and design services.

Graphics Imaging

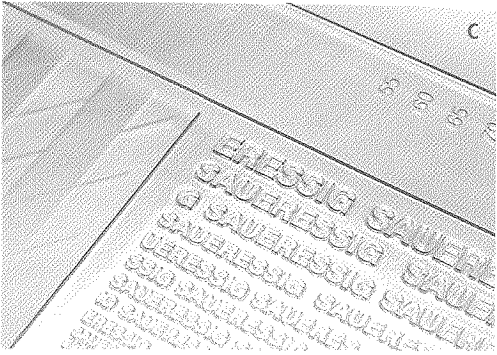
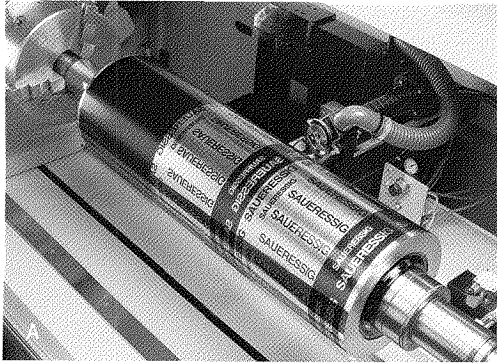

The Graphics Imaging segment provides brand management, pre-press services, printing plates and cylinders, embossing tools and creative design services to the primary packaging and corrugated industries. The segment's principal products and services include brand management, pre-press graphics services, printing plates, gravure cylinders, print process assistance, print production management, digital asset management, content management and package design. These products and services are used by consumer products companies and packaging manufacturers to develop and print packaging graphics that identify and help sell the product in the marketplace. ■

(A) (B) and (C) Saueressig is one of the world's top suppliers of print and embossing technologies. With its years of experience as a link between large-branded companies and printing plants, Saueressig has grown into an innovative system supplier with its SCM Media Service technology. SCM is a multi-company link that enables the creation of digital order files for the total print production process – from the end product manufacturer, to the advertising agency, to the cylinder manufacturer and finally, to the printer.

(D) Matthews provides printing plates for corrugated packaging and point of sale displays for Scotts, a leading global maker and marketer of horticultural and turf products.

(E) Martinson Coffee relied on the Matthews creative design team for a brand redesign in which a new logo and branding concept was created in order to rejuvenate the product while retaining a sense of history.

(F) Colgate-Palmolive is a leading consumer products company selling its products in over 200 countries and territories around the world. Matthews partners with Colgate on global initiatives in order to achieve consistent brand execution across multiple geographies, cultures and languages.

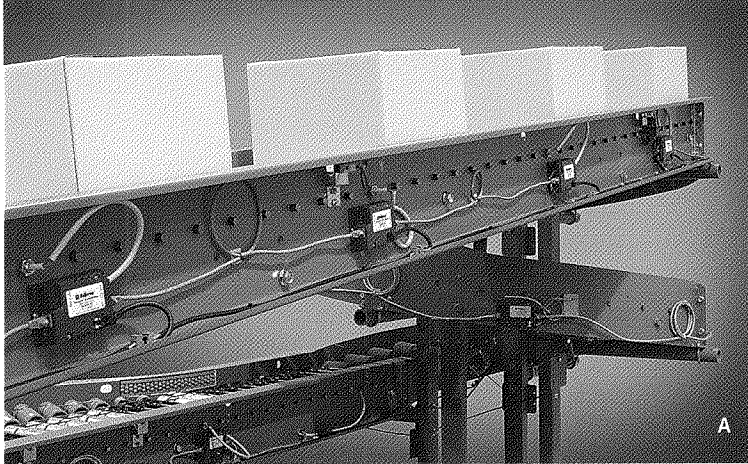

The Marking Products segment designs, manufactures and distributes a wide range of marking and coding products and related consumables, as well as industrial automation products. The Company's products are used by manufacturers and suppliers to identify, track and convey their products and packaging. Marking technologies include contact and ink-jet printing using a wide range of specialty inks, as well as indenting and etching processes. Marking solutions can be a stand-alone operation or integrated directly into the manufacturing process at high speeds with extreme accuracy. ■

(A) Conveyor Controls – Hojeron continues to be a market leader in automated conveyor and specialty network controls for the oilfield and homeland security industries. The Hojeron Microroller® motorized roller and ZoneLink® product lines offer exceptional energy savings, reduced maintenance cost and quiet, safe operation of conveyors.

(B) Matthews Print Heads are constructed of rugged enclosures for maximum durability in the most challenging environments. Matthews 8000 series print heads feature precision jeweled nozzles set in stainless steel face plates, providing higher resolution at faster line speeds.

(C) Laser Marking and Coding Systems – Matthews sells world-leading industrial CO₂ and Fiber-YAG laser marking and coding systems. Lasers

produce visible codes and graphic logos on manufactured goods and food product packaging by changing the properties of the material or by inscribing its surface.

(D) The ProPoint™ P31 indenting marking system uses a computer controlled carbide stylus tip to permanently mark variable information onto metal and plastic parts. The 10.4" color touch screen makes for easy message file creation and editing.

(E) Ink-jet Printers – The newest printer in the continuous ink-jet family is the CX16. It is the most affordable CIJ printer on the market, ideal for small character printing of variable information onto a multitude of products in the food and beverage, electronics, pharmaceutical, building products, automotive and cosmetics industries.

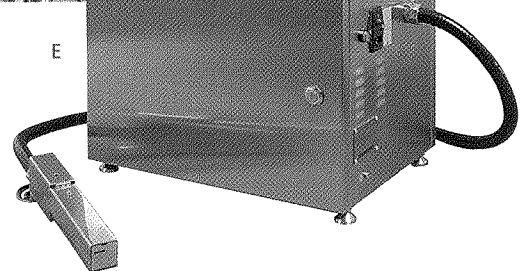
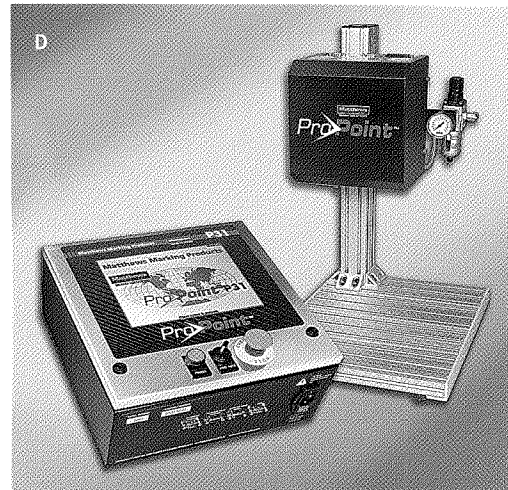
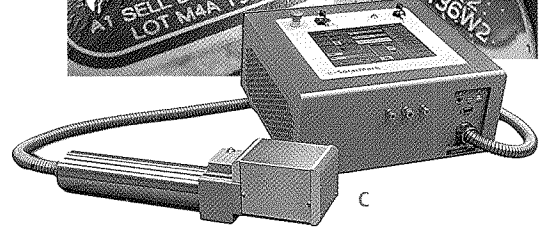
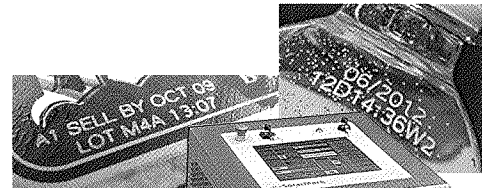
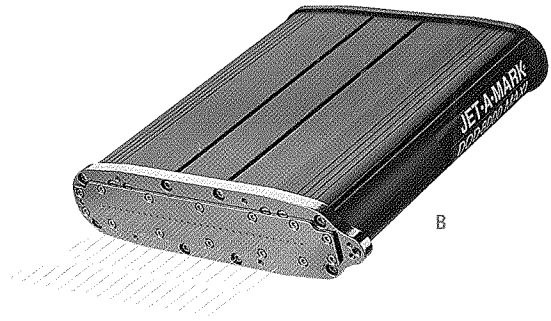

Marking Products

Merchandising Solutions

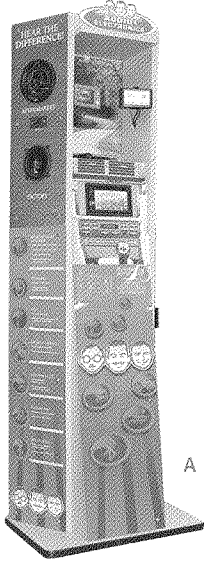

The Merchandising Solutions segment is an industry leader in providing value-added comprehensive merchandising solutions to consumer product marketers and retailers in industries such as electronics, technology, entertainment, food and beverage, apparel, footwear, home improvement, petroleum, appliances and flooring. The segment designs, engineers, manufactures and installs merchandising and display systems, and also provides creative merchandising and marketing solutions services. ■

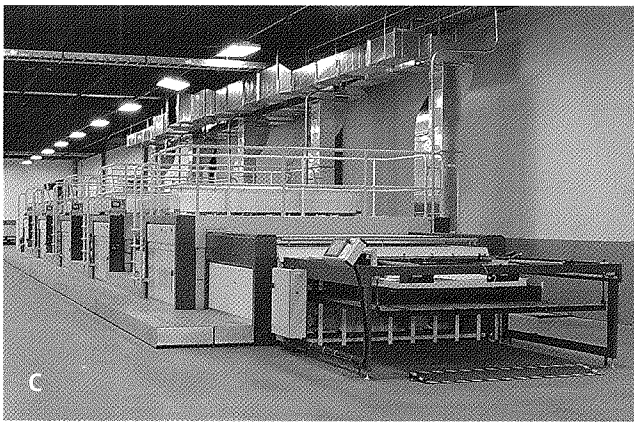

(A) Pep Boys – Matthews collaborated with the Pep Boys design team to design, engineer, produce and ship 20 Mobile Electronics Free Standing Displays as an initial test.

(B) GNC – GNC's major project launches in 2009 included AMP, Wellbeing and The Big Health Guide, with Matthews supporting the design, engineering, printing and shipping of each launch.

(C) Thieme 5 Station In-Line Press – Matthews stays on the cutting edge of large format screen printing technology to meet the needs of world-class brands and retailers.

(D) www.idtwww.com – The segment's new website combines contemporary design with clear and direct communications, setting the tone for the Company's culture and its connection with world-class brands and retailers.

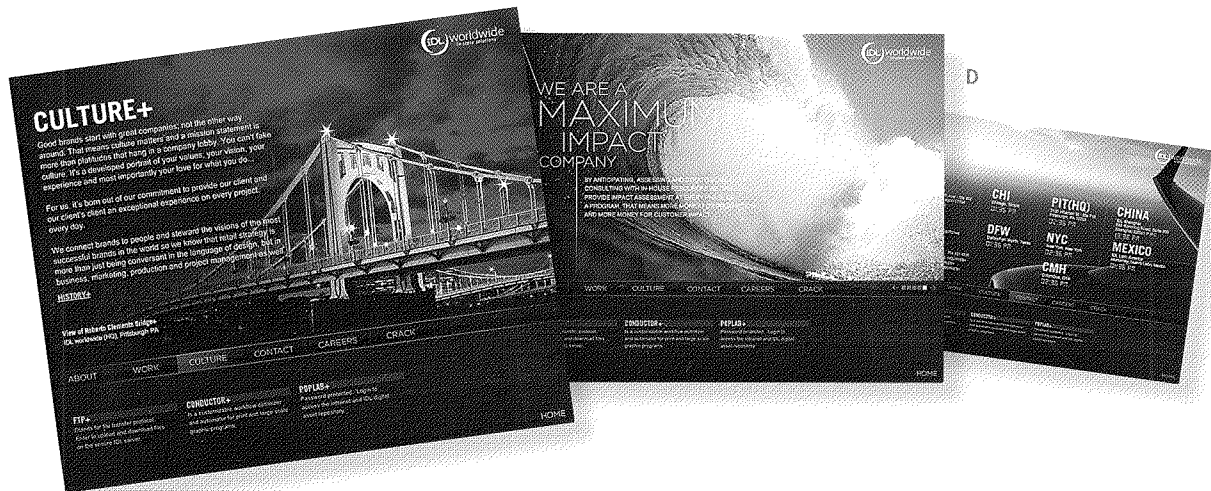

UNITED STATES
SECURITIES AND EXCHANGE COMMISSION
Washington, D.C. 20549

FORM 10-K

ANNUAL REPORT PURSUANT TO SECTION 13 OR 15(d) OF THE
SECURITIES EXCHANGE ACT OF 1934

For the fiscal year ended September 30, 2009
Commission File Number 0-09115

MATTHEWS INTERNATIONAL CORPORATION

(Exact name of registrant as specified in its charter)

COMMONWEALTH OF PENNSYLVANIA

(State or other jurisdiction of
incorporation or organization)

25-0644320

(I.R.S. Employer
Identification No.)

TWO NORTHSORE CENTER, PITTSBURGH, PA

(Address of principal executive offices)

15212-5851

(Zip Code)

Registrant's telephone number, including area code

(412) 442-8200

Securities registered pursuant to Section 12(b) of the Act:

<u>Title of each class</u>	<u>Name of each exchange on which registered</u>
Class A Common Stock, \$1.00 par value	NASDAQ Global Select Market System

Securities registered pursuant to Section 12(g) of the Act: None

Indicate by check mark if the registrant is a well-known seasoned issuer, as defined in Rule 405 of the Securities Act.

Yes No

Indicate by check mark if the registrant is not required to file reports pursuant to Section 13 or Section 15(d) of the Act.

Yes No

Indicate by check mark whether the registrant (1) has filed all reports required to be filed by Section 13 or 15(d) of the Securities Exchange Act of 1934 during the preceding 12 months (or for such shorter period that the registrant was required to file such reports), and (2) has been subject to such filing requirements for the past 90 days.

Indicate by check mark if disclosure of delinquent filers pursuant to Item 405a of Regulation S-K is not contained herein, and will not be contained, to the best of registrant's knowledge, in definitive proxy or information statements incorporated by reference in Part III of this Form 10-K or any amendment to this Form 10-K.

Indicate by check mark whether the registrant has submitted electronically and posted on its corporate Web site, if any, every Interactive Data File required to be submitted and posted pursuant to Rule 405 of Regulation S-T during the preceding 12 months (or for such shorter period that the registrant was required to submit and post such files). Yes No

Indicate by check mark whether the registrant is a large accelerated filer, an accelerated filer, a non-accelerated filer or a smaller reporting company. See definition of "large accelerated filer", "accelerated filer", and "smaller reporting company" in Rule 12b-2 of the Exchange Act.

Large accelerated filer Accelerated filer Non-accelerated filer Smaller reporting company

Indicate by check mark whether the registrant is a shell company (as defined in Rule 12b-2 of the Exchange Act). Yes No

The aggregate market value of the Class A Common Stock outstanding and held by non-affiliates of the registrant, based upon the closing sale price of the Class A Common Stock on the NASDAQ Global Select Market System on March 31, 2009, the last business day of the registrant's most recently completed second fiscal quarter, was approximately \$867 million.

As of October 31, 2009, shares of common stock outstanding were: Class A Common Stock 30,331,268 shares

Documents incorporated by reference: Specified portions of the Proxy Statement for the 2010 Annual Meeting of Shareholders are incorporated by reference into Part III of this Report.

The index to exhibits is on pages 74-76.

PART I

CAUTIONARY STATEMENT REGARDING FORWARD-LOOKING INFORMATION:

Any forward-looking statements contained in this Annual Report on Form 10-K (specifically those contained in Item 1, "Business", Item 1A, "Risk Factors" and Item 7, "Management's Discussion and Analysis of Financial Condition and Results of Operations") are included in this report pursuant to the "safe harbor" provisions of the Private Securities Litigation Reform Act of 1995. Such forward-looking statements involve known and unknown risks and uncertainties that may cause the Company's actual results in future periods to be materially different from management's expectations. Although Matthews International Corporation ("Matthews" or the "Company") believes that the expectations reflected in such forward-looking statements are reasonable, no assurance can be given that such expectations will prove correct. Factors that could cause the Company's results to differ materially from the results discussed in such forward-looking statements principally include changes in domestic or international economic conditions, changes in foreign currency exchange rates, changes in the cost of materials used in the manufacture of the Company's products, changes in death rates, changes in product demand or pricing as a result of consolidation in the industries in which the Company operates, changes in product demand or pricing as a result of domestic or international competitive pressures, unknown risks in connection with the Company's acquisitions and technological factors beyond the Company's control. In addition, although the Company does not have any customers that would be considered individually significant to consolidated sales, changes in the distribution of the Company's products or the potential loss of one or more of the Company's larger customers are also considered risk factors.

ITEM 1. BUSINESS.

Matthews, founded in 1850 and incorporated in Pennsylvania in 1902, is a designer, manufacturer and marketer principally of memorialization products and brand solutions. Memorialization products consist primarily of bronze memorials and other memorialization products, caskets and cremation equipment for the cemetery and funeral home industries. Brand solutions include graphics imaging products and services, marking products, and merchandising solutions. The Company's products and operations are comprised of six business segments: Bronze, Casket, Cremation, Graphics Imaging, Marking Products and Merchandising Solutions. The Bronze segment is a leading manufacturer of cast bronze memorials and other memorialization products, cast and etched architectural products and is a leading builder of mausoleums in the United States. The Casket segment is a leading casket manufacturer and distributor in North America and produces a wide variety of wood and metal caskets. The Cremation segment is a leading designer and manufacturer of cremation equipment and cremation caskets primarily in North America. The Graphics Imaging segment manufactures and provides brand solutions, printing plates, gravure cylinders, pre-press services and imaging services for the primary packaging and corrugated industries. The Marking Products segment designs, manufactures and distributes a wide range of marking and coding equipment and consumables, and industrial automation products for identifying, tracking and conveying various consumer and industrial products, components and packaging containers. The Merchandising Solutions segment designs and manufactures merchandising displays and systems and provides creative merchandising and marketing solutions services.

At October 31, 2009, the Company and its majority-owned subsidiaries had approximately 4,500 employees. The Company's principal executive offices are located at Two NorthShore Center, Pittsburgh, Pennsylvania 15212, its telephone number is (412) 442-8200 and its internet website is www.matw.com. The Company files all required reports with the Securities and Exchange Commission ("SEC") in accordance with the Exchange Act. These reports are available free of charge on the Company's website as soon as practicable after being filed or furnished to the SEC. The reports filed with the SEC are also available to read and copy at the SEC's Public Reference Room at 100 F Street, N.E., Washington, D.C. 20549 or by contacting the SEC at 1-800-732-0330. All reports filed with the SEC can be found on its website at www.sec.gov.

The following table sets forth reported sales and operating profit for the Company's business segments for the past three fiscal years. Detailed financial information relating to business segments and to domestic and international operations is presented in Note 16 ("Segment Information") to the Consolidated Financial Statements included in Part II of this Annual Report on Form 10-K.

Years Ended September 30,

	2009		2008		2007	
	Amount	Percent	Amount	Percent	Amount	Percent
(Dollars in Thousands)						
Sales to unaffiliated customers:						
Memorialization:						
Bronze	\$215,934	27.7%	\$243,063	29.7%	\$229,850	30.7%
Casket	203,247	26.0	219,792	26.8	210,673	28.1
Cremation	30,909	4.0	26,665	3.3	25,166	3.3
	450,090	57.7	489,520	59.8	465,689	62.1
Brand Solutions:						
Graphics Imaging	234,966	30.1	203,703	24.9	146,049	19.5
Marking Products	42,355	5.4	60,031	7.3	57,450	7.7
Merchandising Solutions	53,497	6.8	65,369	8.0	80,164	10.7
	330,818	42.3	329,103	40.2	283,663	37.9
Total	\$780,908	100.0%	\$818,623	100.0%	\$749,352	100.0%
Operating profit:						
Memorialization:						
Bronze	\$ 57,598	57.0%	\$ 71,576	53.8%	\$ 66,298	59.3%
Casket	17,716	17.5	23,339	17.6	11,801	10.6
Cremation	5,036	5.0	5,474	4.1	3,631	3.2
	80,350	79.5	100,389	75.5	81,730	73.1
Brand Solutions:						
Graphics Imaging	19,217	19.0	18,617	14.0	14,439	12.9
Marking Products	1,500	1.5	9,137	6.9	9,931	8.9
Merchandising Solutions	(56)	—	4,809	3.6	5,724	5.1
	20,661	20.5	32,563	24.5	30,094	26.9
Total	\$101,011	100.0%	\$132,952	100.0%	\$111,824	100.0%

In fiscal 2009, approximately 64% of the Company's sales were made from the United States, and 32%, 2%, 1% and 1% were made from Europe, Canada, Australia and Asia, respectively. For further information on Segments see Note 16, "Segment Information" in Item 8 – "Financial Statements and Supplementary Data" on pages 59 and 60 of this report. Bronze segment products are sold throughout the world with the segment's principal operations located in the United States, Europe, Canada, and Australia. Casket segment products are primarily sold in North America. Cremation segment products and services are sold primarily in North America, Europe, Asia, and Australia. Products and services of the Graphics Imaging segment are sold primarily in Europe, the United States and Asia. The Marking Products segment sells equipment and consumables directly to industrial consumers and distributors in the United States and internationally through the Company's subsidiaries in Canada, Sweden and China, and through other foreign distributors. Matthews owns a minority interest in Marking Products distributors in Asia, Australia and Europe. Merchandising Solutions segment products and services are sold principally in the United States.

MEMORIALIZATION PRODUCTS AND MARKETS:

Bronze:

The Bronze segment manufactures and markets products used primarily in the cemetery and funeral home industries. The segment's products, which are sold principally in the United States, Europe, Canada and Australia, include cast bronze memorials and other memorialization products used primarily in cemeteries. The segment also manufactures and markets cast and etched architectural products that are produced from bronze, aluminum and other metals, which are used to identify or commemorate people, places, events and accomplishments.

Memorial products, which comprise the majority of the Bronze segment's sales, include flush bronze memorials, flower vases, crypt plates and letters, cremation urns, niche units, cemetery features and statues, along with other related products and services. Flush bronze memorials are bronze plaques which contain personal information about a deceased individual such as name, birth date, death date and emblems. These memorials are used in cemeteries as an alternative to upright and flush granite monuments. The memorials are even or "flush" with the ground and therefore are preferred by many cemeteries for easier mowing and general maintenance. In order to provide products for the granite memorial and mausoleum markets, the Company's other memorial products include community and family mausoleums, granite monuments and benches, bronze plaques, letters, emblems, vases, lights and photoceramics that can be affixed to granite monuments, mausoleums, crypts and flush memorials. Matthews is a leading builder of mausoleums within North America. Principal customers for memorial products are cemeteries and memorial parks, which in turn sell the Company's products to the consumer.

Customers of the Bronze segment can also purchase memorials and vases on a "pre-need" basis. The "pre-need" concept permits families to arrange for these purchases in advance of their actual need. Upon request, the Company will manufacture the memorial to the customer's specifications (e.g., name and birth date) and place it in storage for future delivery. All memorials in storage have been paid in full with title conveyed to each pre-need purchaser.

The Bronze segment manufactures a full line of memorial products for cremation, including urns in a variety of sizes, styles and shapes. The segment also manufactures bronze and granite niche units, which are comprised of numerous compartments used to display cremation urns in mausoleums and churches. In addition, the Company also markets turnkey cremation gardens, which include the design and all related products for a cremation memorial garden.

Architectural products include cast bronze and aluminum plaques, etchings and letters that are used to recognize, commemorate and identify people, places, events and accomplishments. The Company's plaques are frequently used to identify the name of a building or the names of companies or individuals located within a building. Such products are also used to commemorate events or accomplishments, such as military service or financial donations. The principal markets for the segment's architectural products are corporations, fraternal organizations, contractors, churches, hospitals, schools and government agencies. These products are sold to and distributed through a network of independent dealers including sign suppliers, awards and recognition companies, and trophy dealers.

Raw materials used by the Bronze segment consist principally of bronze and aluminum ingot, sheet metal, coating materials, photopolymers and construction materials and are generally available in adequate supply. Ingot is obtained from various North American, European and Australian smelters.

Competition from other bronze memorialization product manufacturers is on the basis of reputation, product quality, delivery, price and design availability. The Company also competes with upright granite monument and flush granite memorial providers. The Company believes that its superior quality, broad product lines, innovative designs, delivery capability, customer responsiveness, experienced personnel and consumer-oriented merchandising systems are competitive advantages in its markets. Competition in the mausoleum construction industry includes various construction companies throughout North America and is on the basis of design, quality and price. Competitors in the architectural market are numerous and include companies that manufacture cast and painted signs, plastic materials, sand-blasted wood and other fabricated products.

Casket:

The Casket segment is a leading manufacturer and distributor of caskets in North America. The segment produces two types of caskets: metal and wood. Caskets can be customized with many different options such as color, interior design, handles and trim in order to accommodate specific religious, ethnic or other personal preferences.

Metal caskets are made from various gauges of cold-rolled steel, stainless steel, copper and bronze. Metal caskets are generally categorized by whether the casket is non-gasketed or gasketed, and by material (i.e., bronze, copper, or steel) and in the case of steel, by the gauge (thickness) of the metal.

The segment's wood caskets are manufactured from nine different species of wood, as well as from veneer. The species of wood used are poplar, pine, ash, oak, pecan, maple, cherry, walnut and mahogany. The Casket segment is a leading manufacturer of all-wood constructed caskets, which are manufactured using pegged and dowelled construction, and include no metal parts. All-wood constructed caskets are preferred by certain religious groups.

The segment also produces casket components. Casket components include stamped metal parts, metal locking mechanisms for gasketed metal caskets, adjustable beds, interior panels and plastic ornamental hardware for the exterior of the casket. Metal casket parts are produced by stamping cold-rolled steel, stainless steel, copper and bronze sheets into casket body parts. Locking mechanisms and adjustable beds are produced by stamping and assembling a variety of steel parts. Certain ornamental hardware styles are produced from injection molded plastic. The segment purchases from sawmills and lumber distributors various species of uncured wood, which it dries and cures. The cured wood is processed into casket components.

Additionally, the segment provides assortment planning and merchandising and display products to funeral service businesses. These products assist funeral service professionals in providing value and satisfaction to their client families.

The primary materials required for casket manufacturing are cold-rolled steel and lumber. The segment also purchases copper, bronze, stainless steel, cloth, ornamental hardware and coating materials. Purchase orders or supply agreements are typically negotiated with large, integrated steel producers that have demonstrated timely delivery, high quality material and competitive prices. Lumber is purchased from a number of sawmills and lumber distributors. The Company purchases most of its lumber from sawmills within 150 miles of its wood casket manufacturing facility in York, Pennsylvania.

The segment markets its casket products in the United States through a combination of Company-owned and independent casket distribution facilities. The Company operates approximately 45 distribution centers in the United States. Over 75% of the segment's casket products are currently sold through Company-owned distribution centers.

The casket business is highly competitive. The segment competes with other manufacturers on the basis of product quality, price, service, design availability and breadth of product line. The segment provides a line of casket products that it believes is as comprehensive as any of its major competitors. There are a large number of casket industry participants operating in North America, and the industry has recently seen a few new foreign casket manufacturers, primarily from China, enter the North American market. The Casket segment and its two largest competitors account for a substantial portion of the finished caskets produced and sold in North America.

Historically, the segment's operations have experienced seasonal variations. Generally, casket sales are higher in the second quarter and lower in the fourth quarter of each fiscal year. These fluctuations are due in part to the seasonal variance in the death rate, with a greater number of deaths generally occurring in cold weather months.

Cremation:

The Cremation segment has four major groups of products and services: cremation equipment, cremation caskets, equipment service and repair, and supplies and urns.

The Cremation segment is the leading designer and manufacturer of cremation equipment, serving North America, Europe, Australia and Asia. Cremation equipment includes systems for cremation of humans and animals, as well as equipment for processing the cremated remains and other related equipment such as handling equipment (tables, cooler racks, vacuums). Cremation equipment and products are sold primarily to funeral homes, cemeteries, crematories, animal disposers and veterinarians within North America, Europe, Australia and Asia.

Cremation casket products consist primarily of three types of caskets: cloth-covered wood, cloth-covered corrugated material and paper veneer-covered particleboard and corrugated material. These products are generally used in cremation and are marketed principally in the United States through independent distributors and company-owned distribution centers operated by the Company's Casket segment.

Service and repair consists of maintenance work performed on various makes and models of cremation equipment. This work can be as simple as routine maintenance offered at-need or through annual service contracts, or as complex as complete on-site reconstruction. The principal markets for these services are the owners and operators of cremation equipment. These services are marketed principally in North America through Company sales representatives.

Supplies and urns are consumable items associated with cremation operations. Supplies distributed by the segment include operator safety equipment, identification discs and combustible roller tubes. Urns distributed by the segment include products ranging from plastic containers to bronze urns for cremated remains. These products are marketed primarily in North America.

Raw materials used by the Cremation segment consist principally of structural steel, sheet metal, electrical components, cloth, wood, particleboard, corrugated materials, paper veneer and masonry materials and are generally available in adequate supply from numerous suppliers.

The Company competes with several manufacturers in the cremation equipment market principally on the basis of product quality and price. The Cremation segment and its three largest competitors account for a substantial portion of the U.S. cremation equipment market. The cremation casket business is highly competitive. The segment competes with other cremation casket manufacturers on the basis of product quality, price and design availability. Although there are a large number of casket industry participants, the Cremation segment and its two largest competitors account for a substantial portion of the cremation caskets sold in the United States.

Historically, the segment's cremation casket operations have experienced seasonal variations. These fluctuations are due in part to the seasonal variance in the death rate, with a greater number of deaths generally occurring in cold weather months.

BRAND SOLUTIONS PRODUCTS AND MARKETS:

Graphics Imaging:

The Graphics Imaging segment provides brand management, pre-press services, printing plates and cylinders, embossing tools, and creative design services principally to the primary packaging and corrugated industries. The primary packaging industry consists of manufacturers of printed packaging materials such as boxes, flexible packaging, folding cartons and bags commonly seen at retailers of consumer goods. The corrugated packaging industry consists of manufacturers of printed corrugated containers. Other major industries served include the wallpaper, flooring, automotive, and textile industries.

The principal products and services of this segment include brand management, pre-press graphics services, printing plates, gravure cylinders, steel bases, embossing tools, special purpose machinery, engineering assistance, print process assistance, print production management, digital asset management, content management, and package design. These products and services are used by brand owners and packaging manufacturers to develop and print packaging graphics that identify and help sell the product in the marketplace. Other packaging graphics can include nutritional information, directions for product use, consumer warning statements and UPC codes. The primary packaging manufacturer produces printed packaging from paper, film, foil and other composite materials used to display, protect and market the product. The corrugated packaging manufacturer produces printed containers from corrugated sheets. Using the Company's products, these sheets are printed and die cut to make finished containers.

The segment offers a wide array of value-added services and products. These include print process and print production management services; print engineering consultation; pre-press preparation, which includes computer-generated art, film and proofs; plate mounting accessories and various press aids; and rotary and flat cutting dies used to cut out intricately designed containers and point-of-purchase displays. The segment also provides creative digital graphics services to brand owners and packaging markets.

The Company works closely with manufacturers to provide the proper printing forms and tooling used to print the packaging to the user's specifications. The segment's printing plate products are made principally from photopolymer resin and sheet materials. Upon customer request, plates can be pre-mounted press-ready in a variety of configurations that maximize print quality and minimize press set-up time. Gravure cylinders, manufactured from steel, copper and chrome, can be custom engineered for multiple print processes.

The Graphics Imaging segment customer base consists primarily of brand owners and packaging industry converters. Brand owners are generally large, well-known consumer products companies and retailers with a national or global presence. These types of companies tend to purchase their graphics needs directly and supply the printing forms, or the electronic files to make the printing plates and gravure cylinders, to the packaging printer for their products. The Graphics Imaging segment serves customers primarily in Europe, the United States and Asia. In Europe, the segment has its principal operations in Germany, the United Kingdom, Poland and Austria.

Major raw materials for this segment's products include photopolymers, copper, steel, film and graphic art supplies. All such materials are presently available in adequate supply from various industry sources.

The Graphics Imaging segment is one of several manufacturers of printing plates and cylinders and providers of pre-press services with an international presence. The segment competes in a fragmented industry consisting of a few multi-plant regional printing form suppliers and a large number of local single-facility companies located across Europe and the United States. The combination of the Company's Graphics Imaging business in Europe, the United States and Asia is an important part of Matthews' strategy to become a worldwide leader in the graphics industry and service multinational customers on a global basis. Competition is on the basis of product quality, timeliness of delivery, price and value-added services. The Company differentiates itself from the competition by consistently meeting customer demands, its ability to service customers nationally and globally, and its ability to provide value-added services.

Marking Products:

The Marking Products segment designs, manufactures and distributes a wide range of marking and coding products and related consumables, as well as industrial automation products. The Company's products are used by manufacturers and suppliers to identify, track and convey their products and packaging. Marking products can range from a simple hand stamp to microprocessor-based ink-jet printing systems. Coding systems often integrate into the customer's manufacturing, inventory tracking and conveyance control systems. The Company manufactures and markets products and systems that employ the following marking methods to meet customer needs: contact printing, indenting, etching and ink-jet printing. Customers will often use a combination of these methods in order to achieve an appropriate mark. These methods apply product information required for identification and traceability as well as to facilitate inventory and quality control, regulatory compliance and brand name communication.

The segment's industrial automation products are based upon embedded control architecture to create innovative custom solutions which can be "productized." Industries that products are created for include oil exploration, material handling and security scanning. The material handling industry customers include the largest automated assembly and mail sorting companies in the United States.

A significant portion of the revenue of the Marking Products segment is attributable to the sale of consumables and replacement parts in connection with the marking, coding and tracking hardware sold by the Company. The Company develops inks, rubber and steel consumables in harmony with the marking equipment in which they are used, which is critical to assure ongoing equipment reliability and mark quality. Many marking equipment customers also use the Company's inks, solvents and cleaners.

The principal customers for the Company's marking products are consumer goods manufacturers, including food and beverage processors, producers of pharmaceuticals, and manufacturers of durable goods and building products. The Company also serves a wide variety of industrial markets, including metal fabricators, manufacturers of woven and non-woven fabrics, plastic, rubber and automotive products.

A portion of the segment's sales are outside the United States and are distributed through the Company's subsidiaries in Canada, Sweden and China in addition to other international distributors. Matthews owns a minority interest in distributors in Asia, Australia and Europe.

The marking products industry is diverse, with companies either offering limited product lines for well-defined specialty markets, or similar to the Company, offering a broad product line and competing in various product markets and countries. In the United States, the Company has manufactured and sold marking products and related consumable items since 1850.

Major raw materials for this segment's products include precision components, electronics, printing components, tool steels, rubber and chemicals, all of which are presently available in adequate supply from various sources.

Competition for marking products is based on product performance, integration into the manufacturing process, service and price. The Company normally competes with specialty companies in specific brand marking solutions and traceability applications. The Company believes that, in general, it offers the broadest line of marking products to address a wide variety of marking applications.

Merchandising Solutions:

The Merchandising Solutions segment provides merchandising and printing solutions for manufacturers and retailers. The segment designs, manufactures and installs merchandising and display systems, and also provides creative merchandising and marketing solutions services.

The majority of the segment's sales are derived from the design, engineering, manufacturing and installation of merchandising and display systems. These systems include permanent and temporary displays, custom store fixtures, brand concept shops, interactive kiosks, custom packaging, and screen and digitally printed promotional signage. Design and engineering services include concept and model development, graphics design and prototyping. Merchandising and display systems are manufactured to specifications developed by the segment in conjunction with the customer. These products are marketed and sold primarily in the United States.

The segment operates in a fragmented industry consisting primarily of a number of small, locally operated companies. Industry competition is intense and the segment competes on the basis of reliability, creativity and providing a broad array of merchandising products and services. The segment is unique in its ability to provide in-depth marketing and merchandising services as well as design, engineering and manufacturing capabilities. These capabilities allow the segment to deliver complete turnkey merchandising solutions quickly and cost effectively.

Major raw materials for the segment's products include wood, particleboard, corrugated materials, structural steel, plastic, laminates, inks, film and graphic art supplies. All of these raw materials are presently available in adequate supply from various sources.

PATENTS, TRADEMARKS AND LICENSES:

The Company holds a number of domestic and foreign patents and trademarks. However, the Company believes the loss of any or a significant number of patents or trademarks would not have a material impact on consolidated operations or revenues.

BACKLOG:

Because the nature of the Company's Bronze, Graphics Imaging and Merchandising Solutions businesses are primarily custom products made to order with short lead times, backlogs are not generally material except for mausoleums. Backlogs vary in a range of approximately one year of sales for mausoleums. Backlogs for the Casket segment and the cremation casket businesses are not material. Cremation equipment sales backlogs vary in a range of eight to ten months of sales. Backlogs generally vary in a range of up to four weeks of sales in the Marking Products segment. The Company's backlog is expected to be substantially filled in fiscal 2010.

REGULATORY MATTERS:

The Company's operations are subject to various federal, state and local laws and regulations relating to the protection of the environment. These laws and regulations impose limitations on the discharge of materials into the environment and require the Company to obtain and operate in compliance with conditions of permits and other government authorizations. As such, the Company has developed environmental, health and safety policies and procedures that include the proper handling, storage and disposal of hazardous materials.

The Company is party to various environmental matters. These include obligations to investigate and mitigate the effects on the environment of the disposal of certain materials at various operating and non-operating sites. The Company is currently performing environmental assessments and remediation at these sites, as appropriate. In addition, prior to its acquisition, The York Group, Inc. was identified, along with others, by the Environmental Protection Agency as a potentially responsible party for remediation of a landfill site in York, Pennsylvania. At this time, the Company has not been joined in any lawsuit or administrative order related to the site or its clean-up.

At September 30, 2009, an accrual of approximately \$7.3 million had been recorded for environmental remediation (of which \$836,000 was classified in other current liabilities), representing management's best estimate of the probable and reasonably estimable costs of the Company's known remediation obligations. The accrual does not consider the effects of inflation and anticipated expenditures are not discounted to their present value. While final resolution of these contingencies could result in costs different than current accruals, management believes the ultimate outcome will not have a significant effect on the Company's consolidated results of operations or financial position.

ITEM 1A. RISK FACTORS.

There are inherent risks and uncertainties associated with the Company's businesses that could adversely affect its operating performance and financial condition. Set forth below are descriptions of those risks and uncertainties that the Company currently believes to be material. Additional risks not currently known or deemed immaterial may also result in adverse effects on the Company.

Changes in Economic Conditions. Generally, changes in domestic and international economic conditions affect the industries in which the Company and its customers and suppliers operate. These changes include changes in the rate of consumption or use of the Company's products due to economic downturns, volatility in currency exchange rates, and changes in raw material prices resulting from supply and/or demand conditions.

Uncertainty about the current unprecedented global economic conditions poses a risk, as consumers and businesses may continue to postpone or cancel spending. Other factors that could influence customer spending include energy costs, conditions in the credit markets, consumer confidence and other factors affecting consumer spending behavior. These and other economic factors could have an effect on demand for the Company's products and services and negatively impact the Company's financial condition and results of operations.

Changes in Foreign Currency Exchange Rates. Manufacturing and sales of a significant portion of the Company's products are outside the United States, and accordingly, the Company holds assets, incurs liabilities, earns revenue and pays expenses in a variety of currencies. The Company's consolidated financial statements are presented in U.S. dollars, and therefore, the Company must translate the reported values of its foreign assets, liabilities, revenue and expenses into U.S. dollars. Increases or decreases in the value of the U.S. dollar compared to foreign currencies may negatively affect the value of these items in the Company's consolidated financial statements, even though their value has not changed in local currency.

Increased Prices for Raw Materials. The Company's profitability is affected by the prices of the raw materials used in the manufacture of its products. These prices may fluctuate based on a number of factors, including changes in supply and demand, domestic and global economic conditions, currency exchange rates, labor costs and fuel-related costs. If suppliers increase the price of critical raw materials, alternative sources of supply, or an alternative material, may not exist. In addition, to the extent that the Company has quoted prices to or has existing contracts with customers, it may be unable to increase the price of its products to offset the increased costs. Significant raw material price increases that cannot be mitigated by selling price increases or productivity improvements will negatively affect the Company's results of operations.

Changes in Mortality and Cremation Rates. Generally, life expectancy in the United States and other countries in which the Company's Memorialization businesses operate has increased steadily for several decades and is expected to continue to do so in the future. The increase in life expectancy is also expected to impact the number of deaths in the future. Additionally, cremations have steadily grown as a percentage of total deaths in the United States since the 1960's, and are expected to continue to increase in the future. The Company expects that these trends will continue in the future, and the result may affect the volume of bronze memorialization products and burial caskets sold in the United States. However, sales of the Company's Cremation segment may benefit from the growth in cremations.

Changes in Product Demand or Pricing. The Company's businesses have and will continue to operate in competitive markets. Changes in product demand or pricing are affected by domestic and foreign competition and an increase in consolidated purchasing by large customers operating in both domestic and global markets. The Memorialization businesses generally operate in markets with ample supply capacity and demand which is correlated to death rates. The Brand Solutions businesses serve global customers that are requiring their suppliers to be global in scope and price competitive. Additionally, in recent years the Company has witnessed an increase in products manufactured offshore, primarily in China, and imported into the Company's U.S. markets. It is expected that these trends will continue and may affect the Company's future results of operations.

Risks in Connection with Acquisitions. The Company has grown in part through acquisitions, and continues to evaluate acquisition opportunities that have the potential to support and strengthen its businesses. There is no assurance however that future acquisition opportunities will arise, or that if they do, that they will be consummated. In addition, acquisitions involve inherent risks that the businesses acquired will not perform in accordance with expectations, or that synergies expected from the integration of the acquisitions will not be achieved as rapidly as expected, if at all. Failure to effectively integrate acquired businesses could prevent the realization of expected rates of return on the acquisition investment and could have a negative effect on the Company's results of operations and financial condition.

Technological Factors Beyond the Company's Control. The Company operates in certain markets in which technological product development contributes to its ability to compete effectively. There can be no assurance that the Company will be able to develop new products, that new products can be manufactured and marketed profitably, or that new products will successfully meet the expectations of customers.

Changes in the Distribution of the Company's Products or the Loss of a Large Customer. Although the Company does not have any customer that is considered individually significant to consolidated sales, it does have contracts with several large customers in both the Memorialization and Brand Solutions businesses. While these contracts provide important access to large purchasers of the Company's products, they can obligate the Company to sell products at contracted prices for extended periods of time which may, in the short-term, limit the Company's ability to increase prices in response to significant raw material price increases or other factors. Additionally, any significant divestiture of business properties or operations by current customers could result in a loss of business if the Company is not able to maintain the business with the subsequent owners of the properties.

ITEM 1B. UNRESOLVED STAFF COMMENTS.

Not Applicable.

ITEM 2. PROPERTIES.

Principal properties of the Company and its majority-owned subsidiaries as of October 31, 2009 were as follows (properties are owned by the Company except as noted):

Location	Description of Property	
Bronze:		
Pittsburgh, PA	Manufacturing / Division Offices	
Kingwood, WV	Manufacturing	
Melbourne, Australia	Manufacturing	(1)
Parma, Italy	Manufacturing / Warehouse	(1)
Searcy, AR	Manufacturing	
Seneca Falls, NY	Manufacturing	
Casket⁽²⁾:		
Monterrey, Mexico	Manufacturing	(1)
Richmond, IN	Manufacturing	(1)
Richmond, IN	Manufacturing / Metal Stamping	
Richmond, IN	Injection Molding	(1)
York, PA	Manufacturing	
Cremation:		
Apopka, FL	Manufacturing / Division Offices	
Richmond, IN	Manufacturing	(1)
Udine, Italy	Manufacturing	(1)
Graphics Imaging:		
Pittsburgh, PA	Manufacturing / Division Offices	
Jülich, Germany	Manufacturing / Division Offices	
Atlanta, GA	Manufacturing	
Beverly, MA	Manufacturing	(1)
Bristol, England	Manufacturing	
Dallas, TX	Manufacturing	(1)
Goslar, Germany	Manufacturing	(1)
Leeds, England	Manufacturing	(1)
Monchengladbach, Germany	Manufacturing	
Munich, Germany	Manufacturing	(1)
Nuremberg, Germany	Manufacturing	(1)
Oakland, CA	Manufacturing	(1)
Poznan, Poland	Manufacturing	
St. Louis, MO	Manufacturing	
Shenzhen, China	Manufacturing	(1)
Vienna, Austria	Manufacturing	(1)
Vreden, Germany	Manufacturing	
Wan Chai, Hong Kong	Manufacturing	(1)
Marking Products:		
Pittsburgh, PA	Manufacturing / Division Offices	
Gothenburg, Sweden	Manufacturing / Distribution	(1)
Tualatin, OR	Manufacturing	(1)
Beijing, China	Manufacturing	(1)

ITEM 2. PROPERTIES (continued)

Merchandising Solutions:

East Butler, PA Manufacturing / Division Offices

Corporate Office:

Pittsburgh, PA General Offices

⁽¹⁾ These properties are leased by the Company under operating lease arrangements. Rent expense incurred by the Company for all leased facilities was approximately \$13.3 million in fiscal 2009.

⁽²⁾ In addition to the properties listed, the Casket division leases warehouse facilities totaling approximately 836,000 square feet in 23 states under operating leases.

All of the owned properties are unencumbered. The Company believes its facilities are generally well suited for their respective uses and are of adequate size and design to provide the operating efficiencies necessary for the Company to be competitive. The Company's facilities provide adequate space for meeting its near-term production requirements and have availability for additional capacity. The Company intends to continue to expand and modernize its facilities as necessary to meet the demand for its products.

ITEM 3. LEGAL PROCEEDINGS.

Matthews is subject to various legal proceedings and claims arising in the ordinary course of business. Management does not expect that the results of any of these legal proceedings will have a material adverse effect on Matthews' financial condition, results of operations or cash flows.

ITEM 4. SUBMISSION OF MATTERS TO A VOTE OF SECURITY HOLDERS.

No matters were submitted to a vote of the Company's security holders during the fourth quarter of fiscal 2009.

OFFICERS AND EXECUTIVE MANAGEMENT OF THE REGISTRANT

The following information is furnished with respect to officers and executive management as of October 31, 2009:

Name	Age	Positions with Registrant
Joseph C. Bartolacci	49	President and Chief Executive Officer
David F. Beck	57	Controller
Jennifer A. Ciccone	42	Vice President, Human Resources
C. Michael Dempe	53	Chief Operating Officer, IDL Worldwide, Inc.
James P. Doyle	58	Group President, Memorialization
Brian J. Dunn	52	Group President, Graphics and Marking Products
Paul C. Jensen	51	President, Marking Products Division
Sean F. Lydon	46	President, Packaging Graphics Division
Steven F. Nicola	49	Chief Financial Officer, Secretary and Treasurer
Paul F. Rahill	52	President, Cremation Division
Franz J. Schwarz	61	President, Graphics Europe
Brian D. Walters	40	Vice President and General Counsel

Joseph C. Bartolacci was appointed President and Chief Executive Officer effective October 1, 2006. He had been President and Chief Operating Officer since September 1, 2005. Mr. Bartolacci was elected to the Board of Directors on November 15, 2005. He had been President, Casket Division since February 2004 and Executive Vice President of Matthews since January 1, 2004. He had been President, Matthews Europe since April 2002. Prior thereto, he was President, Caggiati, S.p.A. (a wholly-owned subsidiary of Matthews International Corporation) and served as General Counsel of Matthews.

David F. Beck was appointed Controller effective September 15, 2003.

Jennifer A. Ciccone was appointed Vice President, Human Resources effective February 19, 2009. Prior thereto, Ms. Ciccone had been Director, Corporate Human Resources since 2006. Ms. Ciccone joined the Company in 1998 and has held various managerial positions within the Company's Human Resources Department.

C. Michael Dempe has served as Chief Operating Officer of IDL Worldwide, Inc. (formerly Cloverleaf Group, Inc.), a wholly-owned subsidiary of Matthews, since July 2004.

James P. Doyle joined the Company as Group President, Memorialization in December 2006. Prior to joining Matthews, he served as President, Kohler Engine Business (a manufacturer of air and liquid-cooled four cycle engines), a division of Kohler Company, from 2004 to 2006..

Brian J. Dunn was appointed Group President, Graphics and Marking Products effective September 1, 2007. Prior thereto, Mr. Dunn had been President, Marking Products Division.

Paul C. Jensen was appointed President, Marking Products Division in November 2008. Prior thereto, Mr. Jensen served as Vice President, Division Technology for the Marking Products Division from March 2007, and served as Vice President of Holjeron Corporation, a wholly-owned subsidiary of Matthews, since July 2004.

Sean F. Lydon was appointed President, Packaging Graphics Division in October 2008. He joined Matthews in July 2008 as an Operations Manager in the Company's Graphics Imaging segment. Prior to joining Matthews, he served as Director, Supply Chain Operations at Sony Electronics from 2001 to 2008.

Steven F. Nicola was appointed Chief Financial Officer, Secretary and Treasurer effective December 1, 2003.

Paul F. Rahill was appointed President, Cremation Division in October 2002.

Franz J. Schwarz was named President, Graphics Europe in May 2006. He had been Managing Director of S+T Reprotechnik GmbH ("S+T GmbH") (formerly Matthews International GmbH), a wholly-owned subsidiary of Matthews International Corporation, since 2000. He was a partial owner of S+T GmbH, a provider of printing plates and print services located in Jülich, Germany, until September 30, 2005. Matthews owns 100% of S+T GmbH.

Brian D. Walters was appointed Vice President and General Counsel effective February 19, 2009. Mr. Walters joined the Company as Legal Counsel in 2005. Prior to joining the Company, Mr. Walters was a partner with Fried, Walters, Zuschlag & Grochmal, a law firm in Pittsburgh, Pennsylvania.

PART II

**ITEM 5. MARKET FOR REGISTRANT'S COMMON EQUITY
AND RELATED STOCKHOLDER MATTERS.**

Market Information:

The authorized common stock of the Company consists of 70,000,000 shares of Class A Common Stock, \$1 par value. The Company's Class A Common Stock is traded on the NASDAQ Global Select Market System under the symbol "MATW". The following table sets forth the high, low and closing prices as reported by NASDAQ for the periods indicated:

		<u>High</u>	<u>Low</u>	<u>Close</u>
Fiscal 2009:				
Quarter ended:	September 30, 2009	\$36.79	\$28.00	\$35.38
	June 30, 2009	32.17	27.11	31.12
	March 31, 2009	40.52	27.67	28.81
	December 31, 2008	51.05	32.30	36.68
Fiscal 2008:				
Quarter ended:	September 30, 2008	\$58.55	\$43.71	\$50.74
	June 30, 2008	52.00	44.92	45.26
	March 31, 2008	50.75	43.28	48.25
	December 31, 2007	49.50	39.93	46.87

The Company has a stock repurchase program, which was initiated in 1996. Under the program, the Company's Board of Directors has authorized the repurchase of a total of 12,500,000 shares of Matthews' common stock, of which 12,279,922 shares have been repurchased as of September 30, 2009. The buy-back program is designed to increase shareholder value, enlarge the Company's holdings of its common stock, and add to earnings per share. Repurchased shares may be retained in treasury, utilized for acquisitions, or reissued to employees or other purchasers, subject to the restrictions of the Company's Restated Articles of Incorporation.

All purchases of the Company's common stock during fiscal 2009 were part of this repurchase program.

The following table shows the monthly fiscal 2009 stock repurchase activity:

Period	Total number of shares purchased	Average price paid per share	Total number of shares purchased as part of a publicly announced plan	Maximum number of shares that may yet be purchased under the plan
October 2008	295,000	\$43.14	295,000	721,994
November 2008	40,266	35.45	40,266	681,728
December 2008	45,000	37.64	45,000	636,728
January 2009	10,000	33.66	10,000	626,728
February 2009	52,500	35.43	52,500	574,228
March 2009	172,500	29.49	172,500	401,728
April 2009	47,500	27.96	47,500	354,228
May 2009	600	29.60	600	353,628
June 2009	93,050	30.62	93,050	260,578
July 2009	—	—	—	260,578
August 2009	500	36.03	500	260,078
September 2009	40,000	35.39	40,000	220,078
Total	796,916	\$36.09	796,916	

Holders:

Based on records available to the Company, the number of registered holders of the Company's common stock was 531 at October 31, 2009.

Dividends:

A quarterly dividend of \$.07 per share was paid for the fourth quarter of fiscal 2009 to shareholders of record on November 2, 2009. The Company paid quarterly dividends of \$.065 per share for the first three quarters of fiscal 2009 and the fourth quarter of fiscal 2008. The Company paid quarterly dividends of \$.06 per share for the first three quarters of fiscal 2008 and the fourth quarter of fiscal 2007. The Company paid quarterly dividends of \$.055 per share for the first three quarters of fiscal 2007.

Cash dividends have been paid on common shares in every year for at least the past forty years. It is the present intention of the Company to continue to pay quarterly cash dividends on its common stock. However, there is no assurance that dividends will be declared and paid as the declaration and payment of dividends is at the discretion of the Board of Directors of the Company and is dependent upon the Company's financial condition, results of operations, cash requirements, future prospects and other factors deemed relevant by the Board.

PERFORMANCE GRAPH

COMPARISON OF FIVE-YEAR CUMULATIVE RETURN *
 AMONG MATTHEWS INTERNATIONAL CORPORATION,
 S&P 500 INDEX, S&P MIDCAP 400 INDEX AND S&P SMALLCAP 600 INDEX **

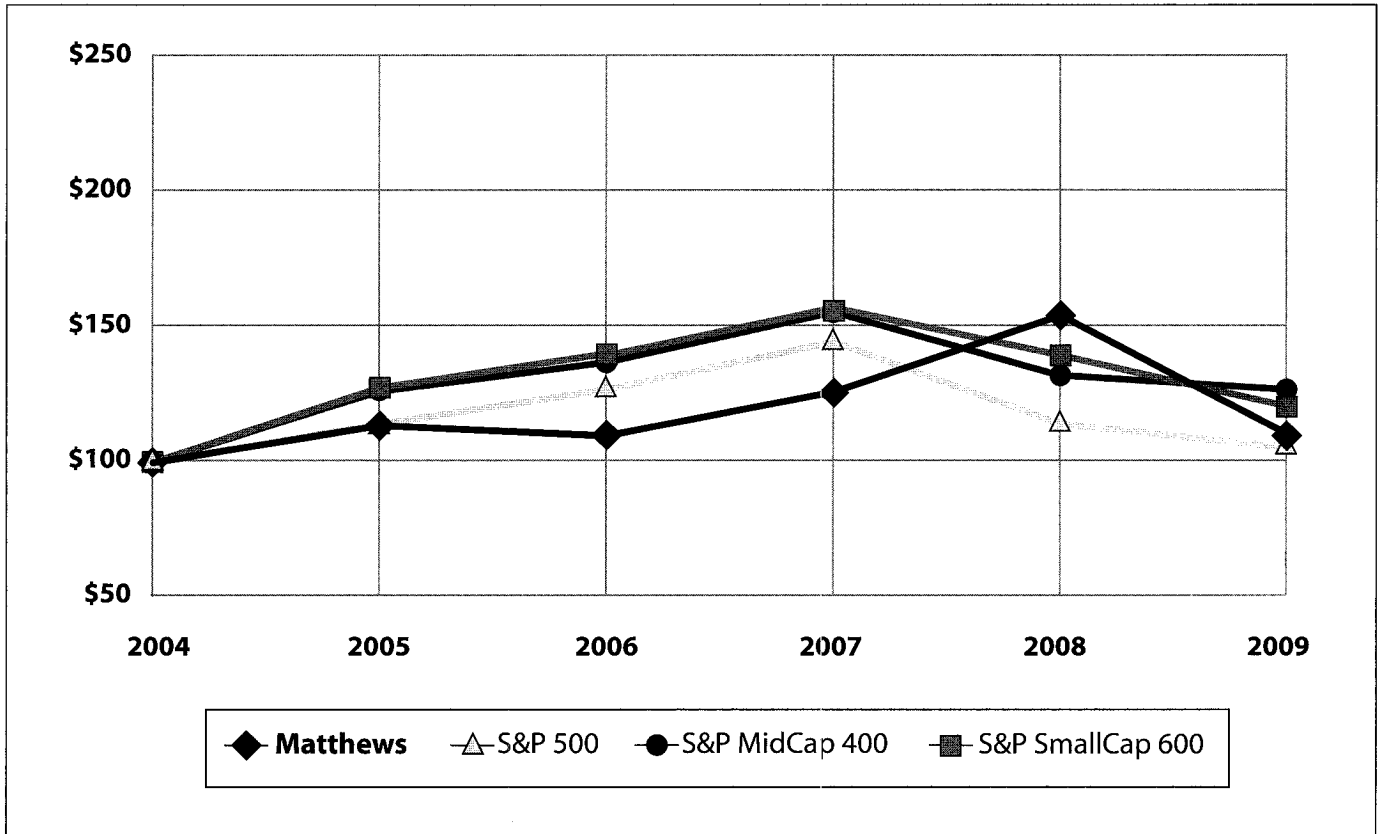

*Total return assumes dividend reinvestment

** Fiscal year ended September 30

Note: Performance graph assumes \$100 invested on October 1, 2004 in Matthews International Corporation Common Stock, Standard & Poor's (S&P) 500 Index, S&P MidCap 400 Index and S&P SmallCap 600 Index. The results are not necessarily indicative of future performance.

ITEM 6. SELECTED FINANCIAL DATA.

	Years Ended September 30,				
	2009 ¹	2008 ²	2007 ³	2006 ⁴	2005
	(Amounts in thousands, except per share data) (Not Covered by Report of Independent Registered Public Accounting Firm)				
Net sales	\$780,908	\$818,623	\$749,352	\$715,891	\$639,822
Gross profit	294,777	322,964	280,457	271,933	223,075
Operating profit	101,011	132,952	111,824	113,884	98,413
Interest expense	12,053	10,405	8,119	6,995	2,966
Income before income taxes	88,543	121,572	103,716	105,408	93,056
Income taxes	30,811	42,088	38,990	38,964	34,985
Net income	\$ 57,732	\$ 79,484	\$ 64,726	\$ 66,444	\$ 58,071
Earnings per common share:					
Basic	\$1.91	\$2.57	\$2.05	\$2.08	\$1.81
Diluted	1.90	2.55	2.04	2.06	1.79
Weighted-average common shares outstanding:					
Basic	30,245	30,928	31,566	31,999	32,116
Diluted	30,435	31,158	31,680	32,252	32,381
Cash dividends per share	\$.265	\$.245	\$.225	\$.205	\$.185
Total assets	\$949,653	\$914,282	\$771,069	\$716,090	\$665,455
Long-term debt, non-current	237,530	219,124	142,273	120,289	118,952

¹ Fiscal 2009 included pre-tax unusual charges of approximately \$16,500, which primarily consisted of severance and other costs related to the consolidation of certain production operations within the Company's Bronze segment, costs related to operational and systems improvements in several of the Company's other businesses, and asset adjustments resulting from current market conditions. In addition, fiscal 2009 earnings included the favorable effect of an adjustment of \$1,255 to income tax expense primarily related to the Company's ability to utilize a European tax loss carryover generated in prior years and changes in the estimated tax accruals for open tax periods.

² Fiscal 2008 included a reduction in income taxes of \$1,882 to reflect the adjustment of net deferred tax liabilities resulting from the enactment of lower statutory income tax rates in certain European countries.

³ Fiscal 2007 included a net pre-tax charge of approximately \$8,765 which consisted primarily of special charges related to the acceleration of earn-out payments in the resolution of employment agreements from the Milso Industries acquisition and pre-tax charges related to severance costs incurred in several of the Company's segments, partially offset by a pre-tax gain on the sale of the marketing consultancy business of the Merchandising Solutions segment and favorable legal settlements, net of related legal costs, in the Casket segment.

⁴ Fiscal 2006 included a net pre-tax gain of \$1,016 which consisted of a pre-tax gain from the sale of a facility, partially offset by a pre-tax charge related to asset impairments and related costs.

ITEM 7. MANAGEMENT'S DISCUSSION AND ANALYSIS OF FINANCIAL CONDITION AND RESULTS OF OPERATIONS.

The following discussion should be read in conjunction with the consolidated financial statements of Matthews International Corporation and related notes thereto. In addition, see "Cautionary Statement Regarding Forward-Looking Information" included in Part I of this Annual Report on Form 10-K.

RESULTS OF OPERATIONS:

The following table sets forth certain income statement data of the Company expressed as a percentage of net sales for the periods indicated and the percentage change in such income statement data from year to year.

	Years Ended September 30,			Percentage Change	
	2009	2008	2007	2009 – 2008	2008 – 2007
Sales	100.0%	100.0%	100.0%	(4.6)%	9.2%
Gross profit	37.7	39.5	37.4	(8.7)	15.2
Operating profit	12.9	16.2	14.9	(24.0)	18.9
Income before taxes	11.3	14.9	13.8	(27.2)	17.2
Net income	7.4	9.7	8.6	(27.4)	22.8

Comparison of Fiscal 2009 and Fiscal 2008:

Sales for the year ended September 30, 2009 were \$780.9 million, compared to \$818.6 million for the year ended September 30, 2008. Excluding the effects of acquisitions, sales declined in each of the Company's segments. The impact of the global recession, an estimated lower domestic casketed death rate compared to a year ago and changes in foreign currency values against the U.S. dollar were the principal factors in the reduction in the Company's consolidated sales. The declines were partially offset by the acquisitions of Saueressig GmbH & Co. KG ("Saueressig"), a manufacturer of gravure printing cylinders, in May 2008 and the acquisition of a small European cremation equipment manufacturer in December 2008. For the year ended September 30, 2009, changes in foreign currency values against the U.S. dollar had an unfavorable impact of approximately \$24.6 million on the Company's consolidated sales compared to the year ended September 30, 2008.

In the Memorialization businesses, Bronze segment sales for fiscal 2009 were \$215.9 million compared to \$243.1 million for fiscal 2008. The decrease primarily reflected a decline in unit volume and decreases in the value of foreign currencies against the U.S. dollar. Sales for the Casket segment were \$203.2 million for fiscal 2009 compared to \$219.8 million for the same period in fiscal 2008. The decrease mainly resulted from lower unit volume and an unfavorable change in product mix. The decline in sales for both the Bronze and Casket segments reflected the impact of the recession on consumer spending, and a decline in the estimated number of casketed deaths compared to the prior year. Sales for the Cremation segment were \$30.9 million for fiscal 2009 compared to \$26.7 million a year ago. The increase principally resulted from the acquisition of a small European cremation equipment manufacturer. In the Company's Brand Solutions businesses, sales for the Graphics Imaging segment in fiscal 2009 were \$235.0 million, compared to \$203.7 million a year ago. The increase resulted from the inclusion of Saueressig for a full year in fiscal 2009, compared to five months in fiscal 2008. Excluding this acquisition, sales were lower in this segment as a result of weak economic conditions and a decrease in the values of foreign currencies against the U.S. dollar. Marking Products segment sales for the year ended September 30, 2009 were \$42.4 million, compared to \$60.0 million for fiscal 2008. The decrease was principally due to lower product demand in the U.S. and foreign markets, reflecting a decline in industrial capital spending and lower sales of consumables. In addition, Marking Products sales were adversely affected by an unfavorable change in the value of foreign currencies against the U.S. dollar. Sales for the Merchandising Solutions segment were \$53.5 million for fiscal 2009, compared to \$65.4 million a year ago. The decrease is attributable to a decline in volume mainly due to project delays or cancellations by customers, also resulting from the downturn in the U.S. economy.

Gross profit for the year ended September 30, 2009 was \$294.8 million, compared to \$323.0 million for fiscal 2008. Consolidated gross profit as a percent of sales decreased to 37.7% for fiscal 2009 from 39.5% for fiscal 2008. The decrease in consolidated gross profit primarily reflected the impact of lower sales, unfavorable changes in the values of foreign currencies against the U.S. dollar, and unusual charges. Unusual charges included in cost of goods sold totaled \$9.0 million and consisted of severance and other expenses related to the facilities consolidation in the Bronze segment, downsizing initiatives in the Sweden operations of the Marking Products segment and costs related to operational and system improvements in several of the Company's other segments.

Selling and administrative expenses for the year ended September 30, 2009 were \$193.8 million, compared to \$190.0 million for fiscal 2008. Consolidated selling and administrative expenses as a percent of sales were 24.8% for the year ended September 30, 2009, compared to 23.2% last year. The increases in costs and percentage of sales primarily resulted from the Saueressig acquisition and unusual charges. Unusual charges included in fiscal 2009 selling and administrative expenses totaled approximately \$7.5 million, and consisted principally of Saueressig integration costs, bad debt expense, termination-related expenses and costs related to operational and system improvements.

Operating profit for fiscal 2009 was \$101.0 million, compared to \$133.0 million for fiscal 2008. Operating profit for fiscal 2009 included unusual charges of approximately \$16.5 million. In addition, changes in the values of foreign currencies against the U.S. dollar had an unfavorable impact of approximately \$3.1 million on consolidated operating profit, compared to the prior year. Bronze segment operating profit for fiscal 2009 was \$57.6 million, compared to \$71.6 million for fiscal 2008. The decrease reflected the impact of lower sales and an unfavorable change in the value of foreign currencies against the U.S. dollar. Additionally, Bronze segment operating profit included unusual charges of approximately \$7.2 million, principally related to facilities consolidations. Operating profit for the Casket segment for fiscal 2009 was \$17.7 million, compared to \$23.3 million for fiscal 2008. The decrease resulted mainly from lower sales and unusual charges of approximately \$2.7 million, which were principally related to bad debt expense, severance and other employment termination-related expenses and cost structure initiatives in the segment's distribution operations. Cremation segment operating profit for the year ended September 30, 2009 was \$5.0 million, compared to \$5.5 million a year ago. The decrease was mainly attributable to the impact of lower domestic sales and unusual charges of approximately \$272,000, partially offset by the acquisition of a small European cremation equipment manufacturer. The Graphics Imaging segment operating profit for fiscal 2009 was \$19.2 million, compared to \$18.6 million for 2008. The increase principally reflected the Saueressig acquisition, offset by the impact of lower sales, unfavorable changes in the values of foreign currencies against the U.S. dollar, and unusual charges of approximately \$3.1 million, which consisted principally of severance charges, asset impairments and Saueressig integration costs. Operating profit for the Marking Products segment for fiscal 2009 was \$1.5 million, compared to \$9.1 million a year ago. The decrease resulted principally from lower sales, an unfavorable change in the values of foreign currencies against the U.S. dollar, and unusual charges of approximately \$1.9 million, which principally related to severance costs and downsizing initiatives in the segment's Sweden operation. The Merchandising Solutions segment reported an operating loss of \$56,000 for fiscal 2009, compared to operating profit of \$4.8 million for fiscal 2008. The decrease principally reflected lower sales and unusual charges of approximately \$1.3 million, which principally related to employment termination-related expenses and asset impairments.

Investment income for the year ended September 30, 2009 was \$2.0 million, compared to \$1.8 million for the year ended September 30, 2008. The increase reflected higher average levels of invested funds. Interest expense for fiscal 2009 was \$12.1 million, compared to \$10.4 million last year. The increase in interest expense primarily reflected higher average debt levels. The higher debt level resulted from borrowings related to the Saueressig acquisition in May 2008.

Other income (deductions), net, for the year ended September 30, 2009 represented a reduction in pre-tax income of \$12,000, compared to an increase in pre-tax income of \$510,000 in fiscal 2008. Minority interest deduction was \$2.5 million for fiscal 2009, compared to \$3.3 million in fiscal 2008. The decrease in the minority interest deduction reflected the Company's purchase of the remaining interest in one of its less than wholly-owned subsidiaries in September 2008, partially offset by improved profitability at Saueressig.

The Company's effective tax rate for fiscal 2009 was 34.8%, compared to 34.6% for fiscal 2008. Fiscal 2009 included the favorable impact of adjustments totaling \$1.3 million in income tax expense related to the Company's ability to utilize a tax loss carryover in Europe and changes in the estimated tax accruals for open tax periods. Fiscal 2008 included the favorable impact of a \$1.9 million reduction in net deferred tax liabilities to reflect the enactment of lower statutory income tax rates in certain European countries. Excluding the one-time adjustments in both periods, the Company's effective tax rate was 36.2% for fiscal years 2009 and 2008. The difference between the Company's effective tax rate and the Federal statutory rate of 35.0% primarily reflected the impact of state and foreign income taxes.

Comparison of Fiscal 2008 and Fiscal 2007:

Sales for the year ended September 30, 2008 were \$818.6 million, compared to \$749.4 million for the year ended September 30, 2007. The increase principally reflected the acquisition of a 78% interest in Saueressig in May 2008, higher sales in the Company's Memorialization businesses, and the effect of higher foreign currency values against the U.S. dollar. The increases were partially offset by the absence of a large one-time Merchandising Solutions project completed in the second quarter of fiscal 2007 (which exceeded \$10.0 million in revenue) and the sale of the segment's marketing consultancy business in August 2007. For the year ended September 30, 2008, changes in foreign currency values against the U.S. dollar had a favorable impact of approximately \$18.0 million on the Company's consolidated sales compared to the year ended September 30, 2007.

In the Memorialization businesses, Bronze segment sales for fiscal 2008 were \$243.1 million compared to \$229.8 million for fiscal 2007. The increase primarily reflected higher selling prices and increases in the value of foreign currencies against the U.S. dollar, partially offset by a decline in the volume of memorial products. Sales for the Casket segment were \$219.8 million for fiscal 2008 compared to \$210.7 million for the same period in fiscal 2007. The increase mainly resulted from higher average selling prices which was partly attributable to the transition to Company-owned distribution in certain territories. Sales for the Cremation segment were \$26.7 million for fiscal 2008 compared to \$25.2 million in fiscal 2007. The increase primarily reflected higher cremation equipment, services and repair revenues. In the Company's Brand Solutions businesses, sales for the Graphics Imaging segment in fiscal 2008 were \$203.7 million, compared to \$146.0 million in fiscal 2007. The increase was mainly due to the Saueressig acquisition, a favorable change in the value of foreign currencies against the U.S. dollar and higher sales in the German markets. The increases were partially offset by lower sales in the U.K. market. Marking Products segment sales for the year ended September 30, 2008 were \$60.0 million, compared to \$57.5 million for fiscal 2007. The increase primarily reflected the acquisition of a 60% interest in Beijing Kenuohua Electronic Technology Co., Ltd. ("Kenuohua"), a Chinese ink-jet equipment manufacturer, in June 2007 and a favorable change in the value of foreign currencies against the U.S. dollar. These increases were partially offset by lower product demand in the domestic market, reflecting a slowdown in the U.S. economy. Sales for the Merchandising Solutions segment were \$65.4 million for fiscal 2008, compared to \$80.2 million in fiscal 2007. The decrease is attributable to a significant one-time project for one of the segment's customers in the second quarter of fiscal 2007, which exceeded \$10.0 million in revenue and did not repeat in fiscal 2008, and the sale of the segment's marketing consultancy business in August 2007.

Gross profit for the year ended September 30, 2008 was \$323.0 million, compared to \$280.5 million for fiscal 2007. The increase in consolidated gross profit primarily reflected the impact of higher sales, the expansion to direct distribution by the Casket segment, the acquisition of Saueressig and the effects of cost structure initiatives implemented in fiscal 2007 in several of the Company's businesses. These gains were partially offset by the impact of lower sales in the U.K. graphics market, the domestic Marking Products business and the Merchandising Solutions segment. Additionally, fiscal 2007 gross profit was impacted by special charges incurred in several of the Company's segments. Consolidated gross profit as a percent of sales increased from 37.4% for fiscal 2007 to 39.5% for fiscal 2008.

Selling and administrative expenses for the year ended September 30, 2008 were \$190.0 million, compared to \$168.6 million for fiscal 2007. Consolidated selling and administrative expenses as a percent of sales were 23.2% for the year ended September 30, 2008, compared to 22.5% in fiscal 2007. The increases in costs and percentage of sales primarily resulted from the continued expansion of the Casket segment's distribution capabilities and the acquisition of Saueressig. Fiscal 2007 included special charges incurred in several of the Company's segments, the most significant of which was the acceleration of earn-out payments in the resolution of employment agreements from the fiscal 2005 acquisition of Milso Industries ("Milso"). These special charges were partially offset by litigation settlements in the Casket segment.

Operating profit for fiscal 2008 was \$133.0 million, compared to \$111.8 million for fiscal 2007. Fiscal 2007 operating profit included unusual items which had a net unfavorable impact of \$8.8 million. The most significant portion of these items (special charges of approximately \$9.4 million) related to the acceleration of earn-out payments in the resolution of employment agreements from the Milso acquisition.

The increase in consolidated operating profit in fiscal 2008 reflected the favorable impact of higher sales, favorable changes in the values of foreign currencies against the U.S. dollar and cost improvements in several of the Company's segments. Bronze segment operating profit for fiscal 2008 was \$71.6 million, compared to \$66.3 million for fiscal 2007. The increase reflected the impact of higher sales and a favorable change in the value of foreign currencies against the U.S. dollar. Operating profit for the Casket segment for fiscal 2008 was \$23.3 million, compared to \$11.8 million for fiscal 2007. Casket segment operating profit for fiscal 2007 reflected special charges of approximately \$10.0 million, including costs related to the resolution of employment agreements from the Milso acquisition and charges related to cost reduction initiatives. These charges were partially offset by favorable litigation settlements (\$2.8 million net of legal costs incurred) in the fiscal 2007 fourth quarter. Excluding these special charges from fiscal 2007, the Casket segment's fiscal 2008 operating profit improved compared to fiscal 2007, reflecting higher sales and the favorable impact of fiscal 2007 cost structure initiatives. Cremation segment operating profit for the year ended September 30, 2008 was \$5.5 million, compared to \$3.6 million in fiscal 2007. The increase was mainly attributable to the impact of higher cremation equipment, services and repair volume, improved price realization, and cost control efforts. The Graphics Imaging segment operating profit for fiscal 2008 was \$18.6 million, compared to \$14.4 million for 2007. Graphics Imaging segment operating profit for fiscal 2007 reflected special charges (mainly severance costs) of approximately \$2.2 million related to cost reduction initiatives in the segment's U.S. and U.K. operations. Excluding these special charges from fiscal 2007, the Graphics Imaging segment fiscal 2008 operating profit improved compared to fiscal 2007, reflecting higher sales in the German markets, a favorable change in foreign currency values against the U.S. dollar and the favorable impact of the fiscal 2007 cost structure initiatives. Operating profit for the Marking Products segment for fiscal 2008 was \$9.1 million, compared to \$9.9 million in fiscal 2007. The decrease resulted principally from lower domestic sales, offset partially by the acquisition of Kenuohua. The Merchandising Solutions segment operating profit was \$4.8 million for fiscal 2008, compared to \$5.7 million for fiscal 2007. Fiscal 2007 operating profit included a \$1.3 million gain on the sale of the segment's marketing consultancy business and the benefit of a significant one-time sales project completed in the second quarter of fiscal 2007. Excluding the gain on the sale of the consulting business in fiscal 2007, the segment's fiscal 2008 operating profit improved compared to fiscal 2007, reflecting the benefit of recent cost structure initiatives. For the year ended September 30, 2008, changes in foreign currency values against the U.S. dollar had a favorable impact of approximately \$3.4 million on the Company's consolidated operating profit compared to the year ended September 30, 2007.

Investment income for the year ended September 30, 2008 was \$1.8 million, compared to \$2.4 million for the year ended September 30, 2007. The decrease reflected lower average levels of invested funds and a decline in investment performance. Interest expense for fiscal 2008 was \$10.4 million, compared to \$8.1 million in fiscal 2007. The increase in interest expense primarily reflected higher average debt levels and higher average interest rates during fiscal 2008 compared to fiscal 2007. The higher debt level resulted from borrowings related to the Saueressig acquisition in May 2008.

Other income, net, for year ended September 30, 2008 was \$510,000, compared to \$354,000 in fiscal 2007. Minority interest deduction was \$3.3 million for fiscal 2008, compared to \$2.7 million in fiscal 2007. The increase in minority interest deduction reflected the Company's acquisition of Kenuohua in June 2007.

The Company's effective tax rate for fiscal 2008 was 34.6%, compared to 37.6% for fiscal 2007. Fiscal 2008 included the favorable impact of a \$1.9 million reduction in net deferred tax liabilities to reflect the enactment of lower statutory income tax rates in certain European countries. Excluding the one-time adjustment to deferred taxes, the Company's effective tax rate was 36.2%. The decrease in the effective tax rate in fiscal 2008 primarily reflected lower statutory tax rates in Europe, the impact of the U.S. Federal manufacturing credit and the closure of several open domestic and foreign tax years. The difference between the Company's effective tax rate and the Federal statutory rate of 35.0% primarily reflected the impact of state and foreign income taxes.

LIQUIDITY AND CAPITAL RESOURCES:

Net cash provided by operating activities was \$90.9 million for the year ended September 30, 2009, compared to \$104.5 million and \$74.6 million for fiscal 2008 and 2007, respectively. Operating cash flow for fiscal 2009 primarily reflected net income adjusted for depreciation and amortization, stock-based compensation expense, minority interest expense and an increase in deferred taxes, partially offset by a cash contribution of \$12.0 million to the Company's principal pension plan. Operating cash flow for fiscal 2008 primarily reflected net income adjusted for depreciation and amortization, stock-based compensation expense, minority interest expense and an increase in deferred taxes, partially offset by cash contributions of \$15.2 million to the Company's principal pension plan. Operating cash flow for fiscal 2007 primarily reflected net income adjusted for depreciation and amortization, stock-based compensation expense, minority interest expense and an increase in deferred taxes, partially offset by an increase in working capital.

Cash used in investing activities was \$32.7 million for the year ended September 30, 2009, compared to \$108.7 million and \$38.7 million for fiscal years 2008 and 2007, respectively. Investing activities for fiscal 2009 primarily reflected payments (net of cash acquired) of \$11.0 million for acquisitions, capital expenditures of \$19.4 million and purchases of investment securities of \$2.6 million. Investing activities for fiscal 2008 primarily reflected payments (net of cash acquired) of \$98.1 million for acquisitions (primarily Saueressig), capital expenditures of \$12.1 million, net proceeds from the sale of investments of \$419,000 and proceeds from the sale of assets of \$1.0 million. Investing activities for fiscal 2007 primarily reflected payments (net of cash acquired) of \$23.8 million for acquisitions, capital expenditures of \$20.6 million, net purchases of investments of \$1.1 million and proceeds of \$6.9 million from the sale of assets. See "Acquisitions" for further discussion of the Company's acquisitions.

Capital expenditures were \$19.4 million for the year ended September 30, 2009, compared to \$12.1 million and \$20.6 million for fiscal 2008 and 2007, respectively. Capital expenditures in each of the last three fiscal years reflected reinvestment in the Company's business segments and were made primarily for the purchase of new manufacturing machinery, equipment and facilities designed to improve product quality, increase manufacturing efficiency, lower production costs and meet regulatory requirements. Capital expenditures for the last three fiscal years were primarily financed through operating cash.

Capital spending for property, plant and equipment has averaged \$17.4 million for the last three fiscal years. The capital budget for fiscal 2010 is \$25.8 million. The Company expects to generate sufficient cash from operations to fund all anticipated capital spending projects.

Cash used in financing activities for the year ended September 30, 2009 was \$53.6 million, reflecting repayments, net of proceeds, on long-term debt of \$15.7 million, purchases of treasury stock of \$28.8 million, proceeds from the sale of treasury stock (stock option exercises) of \$1.2 million, payment of dividends to the Company's shareholders of \$8.2 million (\$0.265 per share) and distributions of \$2.3 million to minority interests. Cash provided by financing activities for the year ended September 30, 2008 was \$13.1 million, reflecting proceeds, net of repayments, from long-term debt of \$43.1 million, proceeds from the sale of treasury stock (stock option exercises) of \$19.2 million, a tax benefit of \$3.1 million from exercised stock options, purchases of treasury stock of \$43.3 million, payment of dividends to the Company's shareholders of \$7.4 million (\$0.245 per share) and distributions of \$1.6 million to minority interests. Cash used in financing activities for the year ended September 30, 2007 was \$27.1 million, reflecting treasury stock purchases of \$56.5 million, net proceeds of long-term debt of \$17.7 million, proceeds of \$16.5 million from the sale of treasury stock (stock option exercises), a tax benefit of \$3.8 million from exercised stock options, dividends of \$7.1 million (\$0.225 per share) to the Company's shareholders and distributions of \$1.6 million to minority interests.

The Company has a domestic Revolving Credit Facility with a syndicate of financial institutions. The maximum amount of borrowings available under the facility is \$225.0 million and the facility's maturity is September 2012. Borrowings under the facility bear interest at LIBOR plus a factor ranging from .40% to .80% based on the Company's leverage ratio. The leverage ratio is defined as net indebtedness divided by EBITDA (earnings before interest, taxes, depreciation and amortization). The Company is required to pay an annual commitment fee ranging from .15% to .25% (based on the Company's leverage ratio) of the unused portion of the facility. The Revolving Credit Facility requires the Company to maintain certain leverage and interest coverage ratios. A portion of the facility (not to exceed \$20.0 million) is available for the issuance of trade and standby letters of credit. Outstanding borrowings on the Revolving Credit Facility at September 30, 2009 and 2008 were \$177.5 million and \$172.5 million, respectively. The weighted-average interest rate on outstanding borrowings at September 30, 2009 and 2008 was 2.96% and 4.35%, respectively.

The Company has entered into the following interest rate swaps:

Date	Initial Amount	Fixed Interest Rate	Interest Rate Spread	
			at September 30, 2009	Maturity Date
September 2007	\$25 million	4.77%	.60%	September 2012
May 2008	40 million	3.72%	.60%	September 2012
October 2008	20 million	3.21%	.60%	October 2010
October 2008	20 million	3.46%	.60%	October 2011

The interest rate swaps have been designated as cash flow hedges of the future variable interest payments under the Revolving Credit Facility which are considered probable of occurring. Based on the Company's assessment, all the critical terms of each of the hedges matched the underlying terms of the hedged debt and related forecasted interest payments, and as such, these hedges were considered highly effective.

The fair value of the interest rate swaps reflected an unrealized loss of \$5.7 million (\$3.5 million after tax) at September 30, 2009 that is included in equity as part of accumulated other comprehensive loss. Assuming market rates remain constant with the rates at September 30, 2009, approximately \$1.5 million of the \$3.5 million loss included in accumulated other comprehensive loss is expected to be recognized in earnings as an adjustment to interest expense over the next twelve months.

The Company, through certain of its German subsidiaries, has a credit facility with a European bank. The maximum amount of borrowings available under this facility is 25.0 million Euros (\$36.6 million). Outstanding borrowings under the credit facility totaled 18.0 million Euros (\$26.3 million) and 22.5 million Euros (\$31.7 million) at September 30, 2009 and 2008, respectively. The weighted-average interest rate on outstanding borrowings under the facility at September 30, 2009 and 2008 was 1.75% and 5.86%, respectively. The facility's maturity is September 2012.

The Company, through its German subsidiary, Saueressig, has several loans with various European banks. Outstanding borrowings on these loans totaled 10.0 million Euros (\$14.7 million) and 11.6 million Euros (\$16.3 million) at September 30, 2009 and 2008, respectively. The weighted-average interest rate on outstanding borrowings of Saueressig at September 30, 2009 and 2008 was 5.89% and 5.79%, respectively.

The Company, through its wholly-owned subsidiary Matthews International S.p.A., has several loans with various Italian banks. Outstanding borrowings on these loans totaled 12.2 million Euros (\$18.0 million) and 15.3 million Euros (\$21.6 million) at September 30, 2009 and 2008, respectively. Matthews International S.p.A. also has three lines of credit totaling 8.4 million Euros (\$12.2 million) with the same Italian banks. Outstanding borrowings on these lines were 2.0 million Euros (\$2.9 million) and 2.3 million Euros (\$3.3 million) at September 30, 2009 and 2008, respectively. The weighted-average interest rate on outstanding Matthews International S.p.A. borrowings at September 30, 2009 and 2008 was 3.76% and 3.88%, respectively.

The Company has a stock repurchase program, which was initiated in 1996. As of September 30, 2009, the Company's Board of Directors had authorized the repurchase of a total of 12,500,000 shares of Matthews' common stock under the program, of which 12,279,922 shares had been repurchased as of September 30, 2009. The buy-back program is designed to increase shareholder value, enlarge the Company's holdings of its common stock, and add to earnings per share. Repurchased shares may be retained in treasury, utilized for acquisitions, or reissued to employees or other purchasers, subject to the restrictions of the Company's Restated Articles of Incorporation.

Consolidated working capital was \$173.1 million at September 30, 2009, compared to \$141.4 million and \$143.1 million at September 30, 2008 and 2007, respectively. Working capital at September 30, 2009 reflected an increase in cash and investments and a reduction in current maturities of long-term debt. Working capital at September 30, 2008 reflected the impact of the Company's working capital management initiatives, primarily in the Casket segment, partially offset by the impact of the acquisition of Saueressig. Working capital at September 30, 2007 reflected higher levels of inventories resulting primarily from the Casket segment's expansion of its distribution capabilities. Cash and cash equivalents were \$57.8 million at September 30, 2009, compared to \$50.7 million and \$44.0 million at September 30, 2008 and 2007, respectively. The Company's current ratio at September 30, 2009 was 2.3, compared to 1.9 and 2.2 at September 30, 2008 and 2007, respectively.

ENVIRONMENTAL MATTERS:

The Company's operations are subject to various federal, state and local laws and regulations relating to the protection of the environment. These laws and regulations impose limitations on the discharge of materials into the environment and require the Company to obtain and operate in compliance with conditions of permits and other government authorizations. As such, the Company has developed environmental, health, and safety policies and procedures that include the proper handling, storage and disposal of hazardous materials.

The Company is party to various environmental matters. These include obligations to investigate and mitigate the effects on the environment of the disposal of certain materials at various operating and non-operating sites. The Company is currently performing environmental assessments and remediation at these sites, as appropriate. In addition, prior to its acquisition, The York Group, Inc. ("York") was identified, along with others, by the Environmental Protection Agency as a potentially responsible party for remediation of a landfill site in York, Pennsylvania. At this time, the Company has not been joined in any lawsuit or administrative order related to the site or its clean-up.

At September 30, 2009, an accrual of approximately \$7.3 million had been recorded for environmental remediation (of which \$836,000 was classified in other current liabilities), representing management's best estimate of the probable and reasonably estimable costs of the Company's known remediation obligations. The accrual, which reflects previously established reserves assumed with the acquisition of York and additional reserves recorded as a purchase accounting adjustment, does not consider the effects of inflation and anticipated expenditures are not discounted to their present value. Changes in the accrued environmental remediation obligation from the prior fiscal year reflect payments charged against the accrual.

While final resolution of these contingencies could result in costs different than current accruals, management believes the ultimate outcome will not have a significant effect on the Company's consolidated results of operations or financial position.

ACQUISITIONS:

Fiscal 2009:

Acquisition spending, net of cash acquired, during the year ended September 30, 2009 totaled \$11.0 million. The acquisitions were not individually, or in the aggregate, material to the Company's consolidated financial position or results of operations.

Fiscal 2008:

Acquisition spending, net of cash acquired, during the year ended September 30, 2008 totaled \$98.1 million, and primarily included the following:

In September 2008, the Company acquired the remaining 20% interest in S+T Gesellschaft fur Reprotechnik GmbH ("S+T GmbH"). The Company had acquired a 50% interest in S+T GmbH in 1998 and a 30% interest in 2005.

In May 2008, the Company acquired a 78% interest in Saueressig, a manufacturer of gravure printing cylinders. Saueressig is headquartered in Vreden, Germany and has its principal manufacturing operations in Germany, Poland and the United Kingdom. The transaction was structured as a stock purchase with a purchase price of approximately 58.1 million Euros (\$90.8 million). The cash portion of the transaction was funded principally through borrowings under the Company's existing credit facilities. In addition, the Company entered into an option agreement related to the remaining 22% interest in Saueressig. The acquisition was designed to expand Matthews' products and services in the global graphics imaging market.

Fiscal 2007:

Acquisition spending, net of cash acquired, during the year ended September 30, 2007 totaled \$23.8 million, and primarily included the following:

In July 2007, York reached a settlement agreement with Yorktowne Caskets, Inc. and its shareholders (collectively "Yorktowne") with respect to all outstanding litigation between the parties. In exchange for the mutual release, the principal terms of the settlement included the assignment by Yorktowne of certain customer and employment-related contracts to York and the purchase by York of certain assets, including York-product inventory, of Yorktowne.

In June 2007, the Company acquired a 60% interest in Kenuohua, an ink-jet equipment manufacturer, headquartered in Beijing, China. The acquisition was structured as a stock purchase. The acquisition was intended to expand Matthews' marking products manufacturing and distribution capabilities in Asia.

In December 2006, the Company paid additional purchase consideration of \$7.0 million under the terms of the Milso acquisition agreement.

DISPOSITION:

In August 2007, the Company sold its marketing consultancy business. The transaction resulted in a pre-tax gain of \$1.3 million, which was recorded as a reduction in administrative expenses in the Company's Consolidated Statement of Income.

FORWARD-LOOKING INFORMATION:

Matthews has a three-pronged strategy to attain annual growth in earnings per share. This strategy, which has remained unchanged from prior years, consists of the following: internal growth (which includes productivity improvements, new product development and the expansion into new markets with existing products), acquisitions and share repurchases under the Company's stock repurchase program (see "Liquidity and Capital Resources"). For the past ten fiscal years, the Company has achieved an average annual increase in earnings per share of 11.1%.

One of the significant factors expected to impact fiscal 2010 results is the continued weakness in the U.S. and global economies, which unfavorably affected sales in both the Memorialization and Brand Solutions businesses in fiscal 2009. There has also been continued volatility in commodity costs, such as bronze, steel and fuel. With these challenges, each of the Company's segments continues to work to increase productivity.

Based on current market conditions, the Company expects these economic challenges to continue, particularly in the next several quarters. Although some of these markets may be beginning to stabilize, the Company is not yet in a position to project a definitive trend toward improvement. In addition, pension costs will increase by approximately \$5.1 million in fiscal 2010 as a result of the market's impact on plan assets and the valuation of the pension obligation compared to fiscal 2009. On this basis, overall earnings for fiscal 2010 are currently expected to be at a level relatively consistent with fiscal 2009 (excluding unusual charges from both years), with results relative to the comparable interim periods in fiscal 2009 improving as fiscal 2010 progresses.

CRITICAL ACCOUNTING POLICIES:

The preparation of financial statements in conformity with generally accepted accounting principles requires management to make estimates and assumptions that affect the reported amounts of assets and liabilities and disclosure of contingent assets and liabilities at the date of the financial statements and the reported amounts of revenues and expenses during the reporting period. Therefore, the determination of estimates requires the exercise of judgment based on various assumptions and other factors such as historical experience, economic conditions, and in some cases, actuarial techniques. Actual results may differ from those estimates. A discussion of market risks affecting the Company can be found in Item 7A, "Quantitative and Qualitative Disclosures about Market Risk," of this Annual Report on Form 10-K.

The Company's significant accounting policies are included in the Notes to Consolidated Financial Statements included in this Annual Report on Form 10-K. Management believes that the application of these policies on a consistent basis enables the Company to provide useful and reliable financial information about the Company's operating results and financial condition. The following accounting policies involve significant estimates, which were considered critical to the preparation of the Company's consolidated financial statements for the year ended September 30, 2009.

Allowance for Doubtful Accounts:

The allowance for doubtful accounts is based on an evaluation of specific customer accounts for which available facts and circumstances indicate collectibility may be uncertain. In addition, the allowance includes a reserve for all customers based on historical collection experience.

Long-Lived Assets:

Property, plant and equipment, goodwill and other intangible assets are carried at cost. Depreciation on property, plant and equipment is computed primarily on the straight-line method over the estimated useful lives of the assets. Property, plant and equipment are reviewed for impairment whenever events or changes in circumstances indicate that the carrying amount of such assets may not be recoverable. Recoverability of assets is determined by evaluating the estimated undiscounted net cash flows of the operations to which the assets relate. An impairment loss would be recognized when the carrying amount of the assets exceeds the fair value which is based on a discounted cash flow analysis.

Goodwill is not amortized, but is subject to periodic review for impairment. In general, when the carrying value of a reporting unit exceeds its implied fair value, an impairment loss must be recognized. For purposes of testing for impairment, the Company uses a combination of valuation techniques, including discounted cash flows. Intangible assets are amortized over their estimated useful lives, unless such lives are considered to be indefinite. A significant decline in cash flows generated from these assets may result in a write-down of the carrying values of the related assets. The Company performed its annual impairment reviews in the second quarters of fiscal 2009, 2008 and 2007 and determined that no adjustments to the carrying values of goodwill or other intangibles were necessary at those times.

Share-Based Payment:

Stock-based compensation cost is measured at grant date, based on the fair value of the award, and is recognized as expense over the employee requisite service period.

Pension and Postretirement Benefits:

Pension assets and liabilities are determined on an actuarial basis and are affected by the market value of plan assets, estimates of the expected return on plan assets and the discount rate used to determine the present value of benefit obligations. Actual changes in the fair market value of plan assets and differences between the actual return on plan assets, the expected return on plan assets and changes in the selected discount rate will affect the amount of pension cost.

The Company's principal pension plan maintains a substantial portion of its assets in equity securities in accordance with the investment policy established by the Company's pension board. Based on an analysis of the historical performance of the plan's assets and information provided by its independent investment advisor, the Company set the long-term rate of return assumption for these assets at 8.5% at September 30, 2009 for purposes of determining pension cost and funded status. The Company's discount rate assumption used in determining the present value of the projected benefit obligation is based upon published indices as of September 30, 2009 for the fiscal 2009 valuation, and as of its plan year-end (July 31) in fiscal 2008 and 2007. The discount rate was 5.50%, 7.00% and 6.50% in fiscal 2009, 2008 and 2007, respectively.

Environmental:

Environmental liabilities are recorded when the Company's obligation is probable and reasonably estimable. Accruals for losses from environmental remediation obligations do not consider the effects of inflation, and anticipated expenditures are not discounted to their present value.

Revenue Recognition:

Revenues are generally recognized when title and risk of loss pass to the customer, which is typically at the time of product shipment. For pre-need sales of memorials and vases, revenue is recognized when the memorial has been manufactured to the customer's specifications (e.g., name and birth date), title has been transferred to the customer and the memorial and vase are placed in storage for future delivery. A liability has been recorded for the estimated costs of finishing pre-need bronze memorials and vases that have been manufactured and placed in storage prior to July 1, 2003 for future delivery. Beginning July 1, 2003, revenue is deferred by the Company on the portion of pre-need sales attributable to the final finishing and storage of the pre-need merchandise. Deferred revenue for final finishing is recognized at the time the pre-need merchandise is finished and shipped to the customer. Deferred revenue related to storage is recognized on a straight-line basis over the estimated average time that pre-need merchandise is held in storage. At September 30, 2009, the Company held 342,336 memorials and 240,143 vases in its storage facilities under the pre-need sales program.

Construction revenues are recognized under the percentage-of-completion method of accounting using the cost-to-cost method.

The Company offers rebates to certain customers participating in volume purchase programs. Rebates are estimated and recorded as a reduction in sales at the time the Company's products are sold.

LONG-TERM CONTRACTUAL OBLIGATIONS AND COMMITMENTS:

The following table summarizes the Company's contractual obligations at September 30, 2009, and the effect such obligations are expected to have on its liquidity and cash flows in future periods.

	Total	Payments due in fiscal year:			
		2010	2011 to 2012	2013 to 2014	After 2014
(Dollar amounts in thousands)					
Contractual Cash Obligations:					
Revolving credit facilities	\$203,841	\$ —	\$203,841	\$ —	\$ —
Notes payable to banks	36,544	6,820	14,723	13,183	1,818
Short-term borrowings	2,855	2,855	—	—	—
Capital lease obligations	7,706	3,434	3,861	411	—
Non-cancelable operating leases	21,466	8,070	9,783	3,017	596
Other	1,391	1,391	—	—	—
Total contractual cash obligations	\$273,803	\$22,570	\$232,208	\$16,611	\$2,414

A significant portion of the loans included in the table above bear interest at variable rates. At September 30, 2009, the weighted-average interest rate was 2.96% on the Company's domestic Revolving Credit Facility, 1.75% on the credit facility through the Company's wholly-owned German subsidiaries, 3.76% on bank loans to the Company's wholly-owned subsidiary, Matthews International S.p.A., and 5.89% on bank loans to its majority-owned subsidiary, Saueressig.

Benefit payments under the Company's principal retirement plan are made from plan assets, while benefit payments under the supplemental retirement plan and postretirement benefit plan are funded from the Company's operating cash. Under IRS regulations, the Company was not required to make any significant contributions to its principal retirement plan in fiscal 2009, however, in fiscal 2009, the Company made a contribution of \$12.0 million to its principal retirement plan. The Company is not required to make any significant cash contributions to its principal retirement plan in fiscal 2010. The Company estimates that benefit payments to participants under its retirement plans (including its supplemental retirement plan) and postretirement benefit payments will be approximately \$5.3 million and \$1.1 million, respectively, in fiscal 2010. The amounts are expected to increase incrementally each year thereafter, to \$6.6 million and \$1.5 million in 2014. The Company believes that its current liquidity sources, combined with its operating cash flow and borrowing capacity, will be sufficient to meet its capital needs for the foreseeable future.

In connection with its acquisition of a 78% interest in Saueressig, the Company entered into an option agreement related to the remaining 22% interest. The option agreement contains certain put and call provisions for the purchase of the remaining 22% interest in future years at a price to be determined by a specified formula based on future operating results of Saueressig. The Company has recorded an estimate of \$27.1 million in "Minority interest and minority interest arrangement" on the September 30, 2009 Consolidated Balance Sheet representing the current estimate of the future purchase price. The timing of the exercise of the put and call provisions is not presently determinable.

Unrecognized tax benefits are positions taken, or expected to be taken, on an income tax return that may result in additional payments to tax authorities. If a tax authority agrees with the tax position taken, or expected to be taken, or the applicable statute of limitations expires, then additional payments will not be necessary. As of September 30, 2009, the Company had unrecognized tax benefits, excluding penalties and interest, of approximately \$3.6 million. The timing of potential future payments related to the unrecognized tax benefits is not presently determinable.

INFLATION:

Except for the volatility in the cost of bronze ingot, steel and fuel (see "Results of Operations"), inflation has not had a material impact on the Company over the past three years nor is it anticipated to have a material impact for the foreseeable future.

ACCOUNTING PRONOUNCEMENTS:

On September 30, 2009, the Company adopted changes issued by the Financial Accounting Standards Board ("FASB") to the authoritative hierarchy of generally accepted accounting principles ("GAAP"). These changes establish the FASB Accounting Standards Codification™ ("Codification") as the source of authoritative accounting principles recognized by the FASB to be used in the preparation of financial statements of nongovernmental entities that are presented in conformity with GAAP in the U.S. The Codification is effective for financial statements issued for interim and annual periods ending after September 15, 2009. The adoption had no material impact on the Company's consolidated results of operations or financial condition.

The Company adopted changes issued by the FASB regarding accounting for income tax benefits of dividends on share-based payment awards on October 1, 2008. The changes require that tax benefits generated by dividends on equity classified non-vested equity shares, non-vested equity share units, and outstanding equity share options be classified as additional paid-in capital and included in a pool of excess tax benefits available to absorb tax deficiencies from share-based payment awards. The adoption had no material impact on the Company's consolidated results of operations or financial condition.

In December 2007, the FASB issued new guidance regarding business combinations. This guidance requires recognition and measurement of the identifiable assets acquired, the liabilities assumed, and any noncontrolling interest in a business combination, goodwill acquired or a gain from a bargain purchase. It is effective for fiscal years beginning on or after December 15, 2008 and is to be applied prospectively. Earlier adoption is not permitted. The Company is currently evaluating the impact of the adoption of this guidance.

In December 2007, the FASB issued new guidance regarding noncontrolling interests in consolidated financial statements. This guidance establishes accounting and reporting standards for the noncontrolling interest in a subsidiary. It requires that consolidated net income reflect the amounts attributable to both the parent and the noncontrolling interest, and also includes additional disclosure requirements. It is effective for fiscal years beginning on or after December 15, 2008 and is to be applied prospectively as of the beginning of the fiscal year in which the guidance is initially applied, except for the presentation and disclosure requirements which shall be applied retrospectively for all periods presented. Earlier adoption is not permitted. The Company is currently evaluating the impact of the adoption of this guidance.

In December 2008, the FASB issued changes to employers' disclosures about postretirement benefit plan assets. These changes require enhanced disclosures regarding assets in defined benefit pension or other postretirement plans. It is effective for fiscal years ending after December 31, 2009. Earlier application is permitted. The Company is currently evaluating the impact of the adoption of these changes.

In April 2009, the FASB issued changes to require disclosures about fair value of financial instruments for interim reporting periods of publicly traded companies as well as in annual financial statements. It also requires those disclosures in summarized financial information at interim reporting periods. These changes are effective for interim reporting periods ending after June 15, 2009 and were adopted by the Company as of June 30, 2009. See Notes 3 and 7 to the Consolidated Financial Statements included in Item 8 of this Annual Report on Form 10-K.

Effective September 30, 2007, the Company adopted the recognition and related disclosure provisions of guidance on employers' accounting for defined benefit pension and other postretirement plans which amended earlier guidance. In the first quarter of fiscal 2009, the Company adopted the provision requiring the Company to measure the plan assets and benefit obligations of defined benefit postretirement plans as of the date of its year-end balance sheet. Adoption of this provision did not have a material effect on the Company's consolidated results of operations or financial condition. See Note 11 to the Consolidated Financial Statements included in Item 8 of this Annual Report on Form 10-K.

In May 2009, the FASB issued new guidance regarding subsequent events. The guidance establishes general standards of accounting for and disclosure of events that occur after the balance sheet date but before financial statements are issued or are available to be issued. The statement is effective for interim or annual financial periods ending after June 15, 2009. Accordingly, the Company adopted these changes as of June 30, 2009. The adoption had no material impact on the Company's consolidated results of operations or financial condition. See Note 21 to the Consolidated Financial Statements included in Item 8 of this Annual Report on Form 10-K.

In June 2008, the FASB issued guidance regarding instruments granted in share-based payments. The guidance requires unvested share-based payment awards that contain non-forfeitable rights to dividends or dividend equivalents (whether paid or unpaid) to be considered participating securities and therefore included in the computation of earnings per share pursuant to the two-class method. This guidance is effective for years beginning after December 31, 2008. The Company is currently evaluating the impact of the adoption of these changes.

ITEM 7A. QUANTITATIVE AND QUALITATIVE DISCLOSURES ABOUT MARKET RISK.

The following discussion about the Company's market risk involves forward-looking statements. Actual results could differ materially from those projected in the forward-looking statements. The Company has market risk related to changes in interest rates, commodity prices and foreign currency exchange rates. The Company does not generally use derivative financial instruments in connection with these market risks, except as noted below.

Interest Rates – The Company's most significant long-term debt instrument is the domestic Revolving Credit Facility, which bears interest at variable rates based on LIBOR.

The Company has entered into the following interest rate swaps:

Date	Initial Amount	Fixed Interest Rate	Interest Rate Spread	
			at September 30, 2009	Maturity Date
September 2007	\$25 million	4.77%	.60%	September 2012
May 2008	40 million	3.72%	.60%	September 2012
October 2008	20 million	3.21%	.60%	October 2010
October 2008	20 million	3.46%	.60%	October 2011

The interest rate swaps have been designated as cash flow hedges of the future variable interest payments under the Revolving Credit Facility which are considered probable of occurring. Based on the Company's assessment, all the critical terms of each of the hedges matched the underlying terms of the hedged debt and related forecasted interest payments, and as such, these hedges were considered highly effective.

The fair value of the interest rate swaps reflected an unrealized loss of \$5.7 million (\$3.5 million after tax) at September 30, 2009 that is included in equity as part of accumulated other comprehensive loss. A decrease of 10% in market interest rates (e.g., a decrease from 5.0% to 4.5%) would result in an increase of approximately \$610,000 in the fair value liability of the interest rate swaps.

Commodity Price Risks – In the normal course of business, the Company is exposed to commodity price fluctuations related to the purchases of certain materials and supplies (such as bronze ingot, steel, fuel and wood) used in its manufacturing operations. The Company obtains competitive prices for materials and supplies when available.

Foreign Currency Exchange Rates – The Company is subject to changes in various foreign currency exchange rates, primarily including the Euro, British Pound, Canadian Dollar, Australian Dollar, Swedish Krona, Chinese Yuan, Hong Kong Dollar and Polish Zloty in the conversion from local currencies to the U.S. dollar of the reported financial position and operating results of its non-U.S. based subsidiaries. An adverse change (strengthening dollar) of 10% in exchange rates would have resulted in a decrease in sales of \$28.5 million and a decrease in operating income of \$3.3 million for the year ended September 30, 2009.

ITEM 8. FINANCIAL STATEMENTS AND SUPPLEMENTARY DATA.

Description	Pages
Management's Report to Shareholders	34
Report of Independent Registered Public Accounting Firm	35
Financial Statements:	
Consolidated Balance Sheets as of September 30, 2009 and 2008	36-37
Consolidated Statements of Income for the years ended September 30, 2009, 2008 and 2007	38
Consolidated Statements of Shareholders' Equity for the years ended September 30, 2009, 2008 and 2007	39
Consolidated Statements of Cash Flows for the years ended September 30, 2009, 2008 and 2007	40
Notes to Consolidated Financial Statements	41-65
Supplementary Financial Information (unaudited)	66
Financial Statement Schedule – Schedule II-Valuation and Qualifying Accounts for the years ended September 30, 2009, 2008 and 2007	67

MANAGEMENT'S REPORT TO SHAREHOLDERS

To the Shareholders and Board of Directors of
Matthews International Corporation:

Management's Report on Financial Statements

The accompanying consolidated financial statements of Matthews International Corporation and its subsidiaries (collectively, the "Company") were prepared by management, which is responsible for their integrity and objectivity. The statements were prepared in accordance with generally accepted accounting principles and include amounts that are based on management's best judgments and estimates. The other financial information included in this Annual Report on Form 10-K is consistent with that in the financial statements.

Management's Report on Internal Control over Financial Reporting

Management is responsible for establishing and maintaining adequate internal control over financial reporting for the Company. In order to evaluate the effectiveness of internal control over financial reporting management has conducted an assessment using the criteria in *Internal Control – Integrated Framework*, issued by the Committee of Sponsoring Organizations of the Treadway Commission ("COSO"). The Company's internal controls over financial reporting include those policies and procedures that (i) pertain to the maintenance of records that, in reasonable detail, accurately and fairly reflect the transactions and dispositions of the assets of the Company; (ii) provide reasonable assurance that transactions are recorded as necessary to permit preparation of financial statements in accordance with generally accepted accounting principles, and that receipts and expenditures of the Company are being made only in accordance with authorizations of management and directors of the Company; and (iii) provide reasonable assurance regarding prevention or timely detection of unauthorized acquisition, use, or disposition of the Company's assets that could have a material effect on the financial statements. Because of its inherent limitations, internal control over financial reporting may not prevent or detect misstatements. Also, projections of any evaluation of effectiveness to future periods are subject to the risk that controls may become inadequate because of changes in conditions, or that the degree of compliance with the policies or procedures may deteriorate.

Based on its assessment, management has concluded that the Company maintained effective internal control over financial reporting as of September 30, 2009, based on criteria in *Internal Control – Integrated Framework* issued by the COSO. The effectiveness of the Company's internal control over financial reporting as of September 30, 2009 has been audited by PricewaterhouseCoopers LLP, an independent registered public accounting firm, as stated in their report which is included herein.

Management's Certifications

The certifications of the Company's Chief Executive Officer and Chief Financial Officer required by the Sarbanes-Oxley Act have been included as Exhibits 31 and 32 in the Company's Form 10-K.

REPORT OF INDEPENDENT REGISTERED PUBLIC ACCOUNTING FIRM

To the Shareholders and Board of Directors of
Matthews International Corporation:

In our opinion, the consolidated financial statements listed in the accompanying index present fairly, in all material respects, the financial position of Matthews International Corporation and its subsidiaries at September 30, 2009 and 2008, and the results of their operations and their cash flows for each of the three years in the period ended September 30, 2009 in conformity with accounting principles generally accepted in the United States of America. In addition, in our opinion, the financial statement schedule listed in the accompanying index presents fairly, in all material respects, the information set forth therein when read in conjunction with the related consolidated financial statements. Also in our opinion, the Company maintained, in all material respects, effective internal control over financial reporting as of September 30, 2009, based on criteria established in *Internal Control - Integrated Framework* issued by the Committee of Sponsoring Organizations of the Treadway Commission (COSO). The Company's management is responsible for these financial statements and financial statement schedule, for maintaining effective internal control over financial reporting and for its assessment of the effectiveness of internal control over financial reporting, included in Management's Report on Internal Control over Financial Reporting appearing under Item 8. Our responsibility is to express opinions on these financial statements, on the financial statement schedule, and on the Company's internal control over financial reporting based on our integrated audits. We conducted our audits in accordance with the standards of the Public Company Accounting Oversight Board (United States). Those standards require that we plan and perform the audits to obtain reasonable assurance about whether the financial statements are free of material misstatement and whether effective internal control over financial reporting was maintained in all material respects. Our audits of the financial statements included examining, on a test basis, evidence supporting the amounts and disclosures in the financial statements, assessing the accounting principles used and significant estimates made by management, and evaluating the overall financial statement presentation. Our audit of internal control over financial reporting included obtaining an understanding of internal control over financial reporting, assessing the risk that a material weakness exists, and testing and evaluating the design and operating effectiveness of internal control based on the assessed risk. Our audits also included performing such other procedures as we considered necessary in the circumstances. We believe that our audits provide a reasonable basis for our opinions.

As discussed in Note 11 to the consolidated financial statements, the Company changed the manner in which it accounts for defined benefit pension and other postretirement benefit plans in 2007.

A company's internal control over financial reporting is a process designed to provide reasonable assurance regarding the reliability of financial reporting and the preparation of financial statements for external purposes in accordance with generally accepted accounting principles. A company's internal control over financial reporting includes those policies and procedures that (i) pertain to the maintenance of records that, in reasonable detail, accurately and fairly reflect the transactions and dispositions of the assets of the company; (ii) provide reasonable assurance that transactions are recorded as necessary to permit preparation of financial statements in accordance with generally accepted accounting principles, and that receipts and expenditures of the company are being made only in accordance with authorizations of management and directors of the company; and (iii) provide reasonable assurance regarding prevention or timely detection of unauthorized acquisition, use, or disposition of the company's assets that could have a material effect on the financial statements.

Because of its inherent limitations, internal control over financial reporting may not prevent or detect misstatements. Also, projections of any evaluation of effectiveness to future periods are subject to the risk that controls may become inadequate because of changes in conditions, or that the degree of compliance with the policies or procedures may deteriorate.

/s/PricewaterhouseCoopers LLP

Pittsburgh, Pennsylvania
November 23, 2009

MATTHEWS INTERNATIONAL CORPORATION AND SUBSIDIARIES
CONSOLIDATED BALANCE SHEETS
September 30, 2009 and 2008

(Dollar amounts in thousands, except per share data)

ASSETS	2009	2008
Current assets:		
Cash and cash equivalents	\$ 57,732	\$ 50,667
Short-term investments	62	62
Accounts receivable, net of allowance for doubtful accounts of \$12,630 and \$11,538, respectively	138,927	145,288
Inventories	94,455	96,388
Deferred income taxes	1,816	1,271
Other current assets	12,430	9,439
Total current assets	305,422	303,115
Investments	13,389	10,410
Property, plant and equipment, net	138,060	145,738
Deferred income taxes	32,563	17,714
Other assets	19,999	17,754
Goodwill	385,219	359,641
Other intangible assets, net	55,001	59,910
Total assets	<u>\$949,653</u>	<u>\$914,282</u>

The accompanying notes are an integral part of these consolidated financial statements.

MATTHEWS INTERNATIONAL CORPORATION AND SUBSIDIARIES
CONSOLIDATED BALANCE SHEETS, continued
September 30, 2009 and 2008

(Dollar amounts in thousands, except per share data)

LIABILITIES AND SHAREHOLDERS' EQUITY	2009	2008
Current liabilities:		
Long-term debt, current maturities	\$ 14,188	\$ 35,144
Trade accounts payable	28,604	26,647
Accrued compensation	35,592	40,188
Accrued income taxes	8,120	12,075
Other current liabilities	45,836	47,656
Total current liabilities	132,340	161,710
Long-term debt	237,530	219,124
Accrued pension	53,734	17,208
Postretirement benefits	24,599	20,918
Deferred income taxes	13,464	10,594
Environmental reserve	6,482	7,382
Other liabilities and deferred revenue	15,489	12,500
Total liabilities	483,638	449,436
Minority interest and minority interest arrangement	31,797	30,891
Commitments and contingent liabilities		
Shareholders' equity:		
Class A common stock, \$1.00 par value; authorized 70,000,000 shares; 36,333,992 shares issued	36,334	36,334
Preferred stock, \$100 par value, authorized 10,000 shares, none issued	—	—
Additional paid-in capital	47,436	47,250
Retained earnings	559,786	511,130
Accumulated other comprehensive loss	(29,884)	(2,979)
Treasury stock, 6,031,674 and 5,474,514 shares, respectively, at cost	(179,454)	(157,780)
Total shareholders' equity	434,218	433,955
Total liabilities and shareholders' equity	\$949,653	\$914,282

The accompanying notes are an integral part of these consolidated financial statements.

MATTHEWS INTERNATIONAL CORPORATION AND SUBSIDIARIES
CONSOLIDATED STATEMENTS OF INCOME
for the years ended September 30, 2009, 2008 and 2007

(Dollar amounts in thousands, except per share data)

	2009	2008	2007
Sales	\$780,908	\$818,623	\$749,352
Cost of sales	(486,131)	(495,659)	(468,895)
Gross profit	294,777	322,964	280,457
Selling expense	(83,576)	(82,677)	(71,623)
Administrative expense	(110,190)	(107,335)	(97,010)
Operating profit	101,011	132,952	111,824
Investment income	2,048	1,808	2,390
Interest expense	(12,053)	(10,405)	(8,119)
Other income (deductions), net	(12)	510	354
Minority interest	(2,451)	(3,293)	(2,733)
Income before income taxes	88,543	121,572	103,716
Income taxes	(30,811)	(42,088)	(38,990)
Net income	<u>\$ 57,732</u>	<u>\$ 79,484</u>	<u>\$ 64,726</u>
Earnings per share:			
Basic	<u>\$1.91</u>	<u>\$2.57</u>	<u>\$2.05</u>
Diluted	<u>\$1.90</u>	<u>\$2.55</u>	<u>\$2.04</u>

The accompanying notes are an integral part of these consolidated financial statements.

MATTHEWS INTERNATIONAL CORPORATION AND SUBSIDIARIES
CONSOLIDATED STATEMENTS OF SHAREHOLDERS' EQUITY
for the years ended September 30, 2009, 2008 and 2007

(Dollar amounts in thousands, except per share data)

	Common Stock	Additional Paid-in Capital	Retained Earnings	Accumulated Other Comprehensive Income (Loss) (net of tax)	Treasury Stock	Total
Balance, September 30, 2006	\$36,334	\$33,953	\$410,203	\$ 4,386	\$ (92,451)	\$392,425
Net income	—	—	64,726	—	—	64,726
Minimum pension liability	—	—	—	2,191	—	2,191
Translation adjustment	—	—	—	16,546	—	16,546
Fair value of derivatives	—	—	—	(740)	—	(740)
Total comprehensive income	—	—	—	—	—	82,723
Initial adoption of pension accounting	—	—	—	(8,993)	—	(8,993)
Stock-based compensation	—	3,509	—	—	—	3,509
Treasury stock transactions:						
Purchase of 1,366,297 shares	—	—	—	—	(56,526)	(56,526)
Issuance of 789,164 shares under stock plans	—	4,108	—	—	16,615	20,723
Dividends, \$.225 per share	—	—	(7,083)	—	—	(7,083)
Balance, September 30, 2007	36,334	41,570	467,846	13,390	(132,362)	426,778
Net income	—	—	79,484	—	—	79,484
Minimum pension liability	—	—	—	(3,049)	—	(3,049)
Translation adjustment	—	—	—	(12,323)	—	(12,323)
Fair value of derivatives	—	—	—	(997)	—	(997)
Total comprehensive income	—	—	—	—	—	63,115
Stock-based compensation	—	4,899	—	—	—	4,899
Treasury stock transactions:						
Purchase of 981,563 shares	—	—	—	—	(46,189)	(46,189)
Issuance of 649,654 shares under stock plans	—	781	—	—	20,771	21,552
Dividends, \$.245 per share	—	—	(7,437)	—	—	(7,437)
Minority interest agreement	—	—	(28,763)	—	—	(28,763)
Balance, September 30, 2008	36,334	47,250	511,130	(2,979)	(157,780)	433,955
Net income	—	—	57,732	—	—	57,732
Minimum pension liability	—	—	(702)	(28,430)	—	(29,132)
Translation adjustment	—	—	—	4,189	—	4,189
Fair value of derivatives	—	—	—	(2,664)	—	(2,664)
Total comprehensive income	—	—	—	—	—	30,125
Stock-based compensation	—	5,822	—	—	—	5,822
Treasury stock transactions:						
Purchase of 796,916 shares	—	—	—	—	(28,813)	(28,813)
Issuance of 241,016 shares under stock plans	—	(5,636)	—	—	7,139	1,503
Dividends, \$.265 per share	—	—	(8,199)	—	—	(8,199)
Minority interest agreement	—	—	(175)	—	—	(175)
Balance, September 30, 2009	\$36,334	\$47,436	\$559,786	\$(29,884)	\$(179,454)	\$434,218

The accompanying notes are an integral part of these consolidated financial statements.

MATTHEWS INTERNATIONAL CORPORATION AND SUBSIDIARIES
CONSOLIDATED STATEMENTS OF CASH FLOWS
for the years ended September 30, 2009, 2008 and 2007

(Dollar amounts in thousands, except per share data)

	2009	2008	2007
Cash flows from operating activities:			
Net income	\$57,732	\$79,484	\$64,726
Adjustments to reconcile net income to net cash provided by operating activities:			
Depreciation and amortization	30,292	24,935	20,528
Minority interest	2,451	3,293	2,733
Stock-based compensation expense	5,822	4,899	3,509
Increase in deferred taxes	7,506	7,270	7,826
(Gain) loss on dispositions of assets	(276)	926	(3,106)
Changes in working capital items	(2,333)	(1,793)	(14,373)
Increase in other assets	(2,245)	(3,653)	(5,113)
(Decrease) increase in other liabilities	(488)	503	(1,225)
Decrease in pension and postretirement benefit obligations	(7,603)	(11,320)	(907)
Net cash provided by operating activities	90,858	104,544	74,598
Cash flows from investing activities:			
Capital expenditures	(19,410)	(12,053)	(20,649)
Acquisitions, net of cash acquired	(10,953)	(98,070)	(23,784)
Proceeds from dispositions of assets	295	980	6,859
Purchases of investment securities	(2,620)	(5,118)	(4,033)
Proceeds from dispositions of investments	—	5,537	2,919
Net cash used in investing activities	(32,688)	(108,724)	(38,688)
Cash flows from financing activities:			
Proceeds from long-term debt	54,128	128,269	75,770
Payments on long-term debt	(69,791)	(85,207)	(58,024)
Purchases of treasury stock	(28,762)	(43,267)	(56,526)
Proceeds from the sale of treasury stock	1,206	19,192	16,524
Tax benefit on exercised stock options	111	3,134	3,834
Dividends	(8,199)	(7,437)	(7,083)
Distributions to minority interests	(2,291)	(1,566)	(1,601)
Net cash (used in) provided by financing activities	(53,598)	13,118	(27,106)
Effect of exchange rate changes on cash	2,493	(2,273)	5,478
Net change in cash and cash equivalents	7,065	6,665	14,282
Cash and cash equivalents at beginning of year	50,667	44,002	29,720
Cash and cash equivalents at end of year	\$57,732	\$50,667	\$44,002
Cash paid during the year for:			
Interest	\$12,550	\$10,574	\$ 8,105
Income taxes	26,032	32,305	31,470

The accompanying notes are an integral part of these consolidated financial statements.

MATTHEWS INTERNATIONAL CORPORATION AND SUBSIDIARIES

NOTES TO CONSOLIDATED FINANCIAL STATEMENTS

(Dollar amounts in thousands, except per share data)

1. NATURE OF OPERATIONS:

Matthews International Corporation (“Matthews” or the “Company”), founded in 1850 and incorporated in Pennsylvania in 1902, is a designer, manufacturer and marketer principally of memorialization products and brand solutions. Memorialization products consist primarily of bronze memorials and other memorialization products, caskets and cremation equipment for the cemetery and funeral home industries. Brand solutions include graphics imaging products and services, marking products and merchandising solutions. The Company’s products and operations are comprised of six business segments: Bronze, Casket, Cremation, Graphics Imaging, Marking Products and Merchandising Solutions. The Bronze segment is a leading manufacturer of cast bronze memorials and other memorialization products, cast and etched architectural products and is a leading builder of mausoleums in the United States. The Casket segment is a leading casket manufacturer and distributor in North America and produces a wide variety of wood and metal caskets. The Cremation segment is a leading designer and manufacturer of cremation equipment and cremation caskets primarily in North America. The Graphics Imaging segment manufactures and provides brand management, printing plates, gravure cylinders, pre-press services and imaging services for the primary packaging and corrugated industries. The Marking Products segment designs, manufactures and distributes a wide range of marking and coding equipment and consumables, and industrial automation products for identifying, tracking and conveying various consumer and industrial products, components and packaging containers. The Merchandising Solutions segment designs and manufactures merchandising displays and systems and provides creative merchandising and marketing solutions services.

The Company has manufacturing and marketing facilities in the United States, Mexico, Canada, Europe, Australia and Asia.

2. SUMMARY OF SIGNIFICANT ACCOUNTING POLICIES:

Principles of Consolidation:

The consolidated financial statements include all domestic and foreign subsidiaries in which the Company maintains an ownership interest and has operating control. All intercompany accounts and transactions have been eliminated.

Use of Estimates:

The preparation of financial statements in conformity with generally accepted accounting principles requires management to make estimates and assumptions that affect the reported amounts of assets and liabilities and the disclosure of contingent assets and liabilities at the date of the financial statements and the reported amounts of revenues and expenses during the reporting period. Actual results could differ from those estimates.

Foreign Currency:

The functional currency of the Company’s foreign subsidiaries is the local currency. Balance sheet accounts for foreign subsidiaries are translated into U.S. dollars at exchange rates in effect at the consolidated balance sheet date. Gains or losses that result from this process are recorded in accumulated other comprehensive income (loss). The revenue and expense accounts of foreign subsidiaries are translated into U.S. dollars at the average exchange rates that prevailed during the period. Gains and losses from foreign currency transactions are recorded in other income (deductions), net.

(Dollar amounts in thousands, except per share data)

2. SUMMARY OF SIGNIFICANT ACCOUNTING POLICIES (continued)

Cash and Cash Equivalents:

For purposes of the consolidated statements of cash flows, the Company considers all investments purchased with a remaining maturity of three months or less to be cash equivalents. The carrying amount of cash and cash equivalents approximates fair value due to the short-term maturities of these instruments.

Allowance for Doubtful Accounts:

The allowance for doubtful accounts is based on an evaluation of specific customer accounts for which available facts and circumstances indicate collectibility may be uncertain. In addition, the allowance includes a reserve for all customers based on historical collection experience.

Inventories:

Inventories are stated at the lower of cost or market with cost generally determined under the average cost method.

Property, Plant and Equipment:

Property, plant and equipment are carried at cost. Depreciation is computed primarily on the straight-line method over the estimated useful lives of the assets, which generally range from 10 to 45 years for buildings and 3 to 12 years for machinery and equipment. Gains or losses from the disposition of assets are reflected in operating profit. The cost of maintenance and repairs is charged against income as incurred. Renewals and betterments of a nature considered to extend the useful lives of the assets are capitalized. Property, plant and equipment are reviewed for impairment whenever events or changes in circumstances indicate that the carrying amount of such assets may not be recoverable. Recoverability of assets is determined by evaluating the estimated undiscounted net cash flows of the operations to which the assets relate. An impairment loss would be recognized when the carrying amount of the assets exceeds the fair value which is based on a discounted cash flow analysis.

Goodwill and Other Intangible Assets:

Goodwill and indefinite-lived intangible assets are not amortized but are subject to annual review for impairment. Other intangible assets are amortized over their estimated useful lives, ranging from 2 to 20 years. In general, when the carrying value of a reporting unit exceeds its implied fair value, an impairment loss must be recognized. For purposes of testing for impairment, the Company uses a combination of valuation techniques, including discounted cash flows. A significant decline in cash flows generated from these assets may result in a write-down of the carrying values of the related assets.

Environmental:

Costs that mitigate or prevent future environmental issues or extend the life or improve equipment utilized in current operations are capitalized and depreciated on a straight-line basis over the estimated useful lives of the related assets. Costs that relate to current operations or an existing condition caused by past operations are expensed. Environmental liabilities are recorded when the Company's obligation is probable and reasonably estimable. Accruals for losses from environmental remediation obligations do not consider the effects of inflation, and anticipated expenditures are not discounted to their present value.

Treasury Stock:

Treasury stock is carried at cost. The cost of treasury shares sold is determined under the average cost method.

(Dollar amounts in thousands, except per share data)

2. SUMMARY OF SIGNIFICANT ACCOUNTING POLICIES (continued)

Income Taxes:

Deferred tax assets and liabilities are provided for the differences between the financial statement and tax bases of assets and liabilities using enacted tax rates in effect for the years in which the differences are expected to reverse. Valuation allowances are recorded to reduce deferred tax assets when it is more likely than not that a tax benefit will not be realized. Deferred income taxes for U.S. tax purposes have not been provided on certain undistributed earnings of foreign subsidiaries, as such earnings are considered to be reinvested indefinitely. To the extent earnings are expected to be returned in the foreseeable future, the associated deferred tax liabilities are provided.

Revenue Recognition:

Revenues are generally recognized when title and risk of loss pass to the customer, which is typically at the time of product shipment. For pre-need sales of memorials and vases, revenue is recognized when the memorial has been manufactured to the customer's specifications (e.g., name and birth date), title has been transferred to the customer and the memorial and vase are placed in storage for future delivery. A liability has been recorded for the estimated costs of finishing pre-need bronze memorials and vases that have been manufactured and placed in storage prior to July 1, 2003 for future delivery. Beginning July 1, 2003, revenue is deferred by the Company on the portion of pre-need sales attributable to the final finishing and storage of the pre-need merchandise. Deferred revenue for final finishing is recognized at the time the pre-need merchandise is finished and shipped to the customer. Deferred revenue related to storage is recognized on a straight-line basis over the estimated average time that pre-need merchandise is held in storage.

At September 30, 2009, the Company held 342,336 memorials and 240,143 vases in its storage facilities under the pre-need sales program.

Construction revenues are recognized under the percentage-of-completion method of accounting using the cost-to-cost method.

The Company offers rebates to certain customers participating in volume purchase programs. Rebates are estimated and recorded as a reduction in sales at the time the Company's products are sold.

Share-Based Payment:

Stock-based compensation cost is measured at grant date, based on the fair value of the award, and is recognized as expense over the employee requisite service period.

Derivatives and Hedging:

Derivatives are held as part of a formal documented hedging program. All derivatives are straight forward and held for purposes other than trading. Matthews measures effectiveness by formally assessing, at least quarterly, the historical and probable future high correlation of changes in the fair value or future cash flows of the hedged item. If the hedging relationship ceases to be highly effective or it becomes probable that an expected transaction will no longer occur, gains and losses on the derivative will be recorded in other income (deductions) at that time.

Changes in the fair value of derivatives designated as cash flow hedges are recorded in other comprehensive income (loss), net of tax and are reclassified to earnings in a manner consistent with the underlying hedged item. The cash flows from derivative activities are recognized in the statement of cash flows in a manner consistent with the underlying hedged item.

(Dollar amounts in thousands, except per share data)

2. SUMMARY OF SIGNIFICANT ACCOUNTING POLICIES (continued)**Research and Development Expenses:**

Research and development costs are expensed as incurred and were approximately \$2,200, \$2,100 and \$2,700 for the years ended September 30, 2009, 2008 and 2007, respectively.

Earnings Per Share:

Basic earnings per share is computed by dividing net income by the average number of common shares outstanding. Diluted earnings per share is computed using the treasury stock method, which assumes the issuance of common stock for all dilutive securities.

3. FAIR VALUE MEASUREMENTS:

The Company adopted new guidance issued by the Financial Accounting Standards Board ("FASB") on fair value measurements as of October 1, 2008 for financial assets and liabilities. This guidance extended the effective date for nonfinancial assets and liabilities to fiscal years beginning after November 15, 2008. The Company is evaluating the potential impact of the provision of the guidance, as it relates to pension plan assets and nonfinancial assets and liabilities on the consolidated financial statements. This new guidance defines fair value as the price that would be received to sell an asset or paid to transfer a liability in an orderly transaction between market participants at the measurement date. It establishes a three level fair value hierarchy to prioritize the inputs used in valuations, as defined below:

Level 1: Observable inputs that reflect unadjusted quoted prices for identical assets or liabilities in active markets.

Level 2: Inputs other than quoted prices included within Level 1 that are observable for the asset or liability, either directly or indirectly.

Level 3: Unobservable inputs for the asset or liability.

As of September 30, 2009, the fair values of the Company's assets and liabilities measured on a recurring basis are categorized as follows:

	Level 1	Level 2	Level 3	Total
Assets:				
Short term investments	\$ 62	—	—	\$ 62
Trading securities	10,774	—	—	10,774
Total assets at fair value	\$10,836	—	—	\$10,836
Liabilities:				
Derivatives ¹	—	\$5,708	—	\$ 5,708
Total liabilities at fair value	—	\$5,708	—	\$ 5,708

¹Interest rate swaps are valued based on observable market swap rates and are classified within Level 2 of the fair value hierarchy.

(Dollar amounts in thousands, except per share data)

4. INVENTORIES:

Inventories at September 30, 2009 and 2008 consisted of the following:

	2009	2008
Materials and finished goods	\$80,692	\$84,925
Labor and overhead in process	13,763	11,463
	<u>\$94,455</u>	<u>\$96,388</u>

5. INVESTMENTS:

Investment securities are recorded at estimated market value at the consolidated balance sheet date and are classified as trading securities. Short-term investments consisted principally of corporate obligations with purchased maturities of over three months but less than one year. The cost of short-term investments approximated market value at September 30, 2009 and 2008. Accrued interest on these non-current investment securities was classified with short-term investments. Investments classified as non-current and trading securities consisted of equity and fixed income mutual funds.

At September 30, 2009 and 2008, non-current investments were as follows:

	2009	2008
Trading securities:		
Mutual funds	\$10,774	\$ 7,671
Equity and other investments	2,615	2,739
	<u>\$13,389</u>	<u>\$10,410</u>

Non-current investments classified as trading securities are recorded at market value, which exceeded cost at September 30, 2009 by approximately \$231. At September 30, 2008, cost exceeded market value of trading securities by approximately \$727.

Realized gains and losses are based on the specific identification method and are recorded in investment income. Realized gains (losses) for fiscal 2009, 2008 and 2007 were not material.

Equity investments primarily included ownership interests in various entities of less than 20%, which are recorded under the cost method of accounting.

(Dollar amounts in thousands, except per share data)

6. PROPERTY, PLANT AND EQUIPMENT:

Property, plant and equipment and the related accumulated depreciation at September 30, 2009 and 2008 were as follows:

	2009	2008
Buildings	\$ 65,824	\$ 74,682
Machinery and equipment	221,723	203,271
	<hr/> 287,547	<hr/> 277,953
Less accumulated depreciation	(167,038)	(143,127)
	<hr/> 120,509	<hr/> 134,826
Land	8,638	8,455
Construction in progress	8,913	2,457
	<hr/> \$138,060	<hr/> \$145,738
	<hr/> <hr/>	<hr/> <hr/>

7. LONG-TERM DEBT:

Long-term debt at September 30, 2009 and 2008 consisted of the following:

	2009	2008
Revolving credit facilities	\$203,841	\$204,171
Notes payable to banks	36,544	43,678
Short-term borrowings	2,855	3,266
Other	1,391	1,327
Capital lease obligations	7,087	1,826
	<hr/> 251,718	<hr/> 254,268
Less current maturities	(14,188)	(35,144)
	<hr/> \$237,530	<hr/> \$219,124
	<hr/> <hr/>	<hr/> <hr/>

The Company has a domestic Revolving Credit Facility with a syndicate of financial institutions. The maximum amount of borrowings available under the facility is \$225,000 and the facility's maturity is September 2012. Borrowings under the facility bear interest at LIBOR plus a factor ranging from .40% to .80% based on the Company's leverage ratio. The leverage ratio is defined as net indebtedness divided by EBITDA (earnings before interest, taxes, depreciation and amortization). The Company is required to pay an annual commitment fee ranging from .15% to .25% (based on the Company's leverage ratio) of the unused portion of the facility. The Revolving Credit Facility requires the Company to maintain certain leverage and interest coverage ratios. A portion of the facility (not to exceed \$20,000) is available for the issuance of trade and standby letters of credit. Outstanding borrowings on the Revolving Credit Facility at September 30, 2009 and 2008 were \$177,500 and \$172,500 respectively. The weighted-average interest rate on outstanding borrowings at September 30, 2009 and 2008 was 2.96% and 4.35%, respectively.

(Dollar amounts in thousands, except per share data)

7. LONG-TERM DEBT (continued)

The Company has entered into the following interest rate swaps:

Date	Initial Amount	Fixed Interest Rate	Interest Rate Spread	
			at September 30, 2009	Maturity Date
September 2007	\$25,000	4.77%	.60%	September 2012
May 2008	40,000	3.72%	.60%	September 2012
October 2008	20,000	3.21%	.60%	October 2010
October 2008	20,000	3.46%	.60%	October 2011

The Company enters into interest rate swaps in order to achieve a mix of fixed and variable rate debt that it deems appropriate. The interest rate swaps have been designated as cash flow hedges of the future variable interest payments under the Revolving Credit Facility which are considered probable of occurring. Based on the Company's assessment, all of the critical terms of each of the hedges matched the underlying terms of the hedged debt and related forecasted interest payments, and as such, these hedges were considered highly effective.

The fair value of the interest rate swaps reflected an unrealized loss of \$5,708 (\$3,482 after tax) at September 30, 2009 that is included in shareholders' equity as part of accumulated other comprehensive loss ("AOCL"). Assuming market rates remain constant with the rates at September 30, 2009, approximately \$1,489 of the \$3,482 loss included in AOCL is expected to be recognized in earnings as an adjustment to interest expense over the next twelve months.

On January 1, 2009, the Company adopted guidance issued by the FASB regarding disclosures about derivative instruments and hedging activities. This guidance amends and expands the disclosure requirements of previous guidance to require qualitative disclosures about objectives and strategies for using derivatives, quantitative disclosures about fair value amounts of and gains and losses on derivative instruments, and disclosures about credit risk-related contingent features in derivative agreements.

At September 30, 2009 and 2008, the interest rate swap contracts were reflected as a liability on the balance sheets. The following derivatives are designated as hedging instruments:

Liability Derivatives

Balance Sheet Location:	2009	2008
Current liabilities:		
Other current liabilities	\$2,441	\$ 580
Long-term liabilities:		
Other accrued liabilities and deferred revenue	3,267	760
Total derivatives	\$5,708	\$1,340

(Dollar amounts in thousands, except per share data)

7. LONG-TERM DEBT (continued)

The income recognized on derivatives was as follows:

Derivatives in Cash Flow Hedging Relationships	Location of Gain or (Loss) Recognized in Income on Derivatives	Amount of Loss Recognized in Income on Derivatives	
		2009	2008
		Interest rate swaps	Interest expense

The Company recognized the following gains or losses in AOCL:

Derivatives in Cash Flow Hedging Relationships	Amount of Loss Recognized in AOCL on Derivatives		Location of Gain or (Loss) Reclassified from AOCL into Income (Effective Portion*)	Amount of Gain or (Loss) Reclassified from AOCL into Income (Effective Portion*)	
	2009	2008		2009	2008
	Interest rate swaps	\$(3,482)		\$(818)	Interest expense

*There is no ineffective portion or amount excluded from effectiveness testing.

The Company, through certain of its German subsidiaries, has a credit facility with a European bank. The maximum amount of borrowings available under this facility is 25.0 million Euros (\$36,585). Outstanding borrowings under the credit facility totaled 18.0 million Euros (\$26,341) and 22.5 million Euros (\$31,671) at September 30, 2009 and 2008, respectively. The weighted-average interest rate on outstanding borrowings under this facility at September 30, 2009 and 2008 was 1.75% and 5.86%, respectively. The facility's maturity is September 2012.

The Company, through its German subsidiary, Saueressig GmbH & Co. KG ("Saueressig"), has several loans with various European banks. Outstanding borrowings under these loans totaled 10.0 million Euros (\$14,717) and 11.6 million Euros (\$16,330) at September 30, 2009 and 2008, respectively. The weighted-average interest rate on outstanding borrowings of Saueressig at September 30, 2009 and 2008 was 5.89% and 5.79%, respectively.

The Company, through its wholly-owned subsidiary, Matthews International S.p.A., has several loans with various Italian banks. Outstanding borrowings on these loans totaled 12.2 million Euros (\$17,962) and 15.3 million Euros (\$21,565) at September 30, 2009 and 2008, respectively. Matthews International S.p.A. also has three lines of credit totaling 8.4 million Euros (\$12,249) with the same Italian banks. Outstanding borrowings on these lines were 2.0 million Euros (\$2,855) and 2.3 million Euros (\$3,256) at September 30, 2009 and 2008, respectively. The weighted-average interest rate on outstanding Matthews International S.p.A. borrowings at September 30, 2009 and 2008 was 3.76% and 3.88%, respectively.

(Dollar amounts in thousands, except per share data)

7. LONG-TERM DEBT (continued)

As of September 30, 2009, the fair value of the Company's long-term debt, including current maturities, was as follows:

Long term debt, including current maturities:	
Carrying value included in the Balance Sheet	\$251,718
Fair Value	\$230,482

The carrying amounts of the Company's borrowings under its financing arrangements at September 30, 2008 approximated fair value.

Aggregate maturities of long-term debt, including short-term borrowings and capital leases, follows:

2010	\$ 14,188
2011	8,182
2012	213,942
2013	12,046
2014	1,542
Thereafter	1,818
	<u>\$251,718</u>

8. SHAREHOLDERS' EQUITY:

The authorized common stock of the Company consists of 70,000,000 shares of Class A Common Stock, \$1 par value.

The Company has a stock repurchase program, which was initiated in 1996. Under the program, the Company's Board of Directors has authorized the repurchase of a total of 12,500,000 shares of Matthews' common stock, of which 12,279,922 shares have been repurchased as of September 30, 2009. The buy-back program is designed to increase shareholder value, enlarge the Company's holdings of its common stock, and add to earnings per share. Repurchased shares may be retained in treasury, utilized for acquisitions, or reissued to employees or other purchasers, subject to the restrictions of the Company's Restated Articles of Incorporation.

Comprehensive income consists of net income adjusted for changes, net of any related income tax effect, in cumulative foreign currency translation, the fair value of derivatives, unrealized investment gains and losses and minimum pension liability.

Accumulated other comprehensive loss at September 30, 2009 and 2008 consisted of the following:

	2009	2008
Cumulative foreign currency translation	\$ 22,392	\$18,203
Fair value of derivatives, net of tax of \$2,226 and \$522, respectively	(3,482)	(818)
Minimum pension liability, net of tax of \$30,965 and \$12,789, respectively	(48,794)	(20,364)
	<u>\$ (29,884)</u>	<u>\$ (2,979)</u>

(Dollar amounts in thousands, except per share data)

9. SHARE-BASED PAYMENTS:

The Company maintains a stock incentive plan (the "1992 Incentive Stock Plan") that provided for grants of stock options, restricted shares and certain other types of stock-based awards. In February 2008, the Company's shareholders approved the adoption of a new plan, the 2007 Equity Incentive Plan (the "2007 Plan"), that provides for the grants of stock options, restricted shares, stock-based performance units and certain other types of stock-based awards. Under the 2007 Plan, which has a ten-year term, the maximum number of shares available for grants or awards is an aggregate of 2,200,000. There will be no further grants under the 1992 Incentive Stock Plan. At September 30, 2009, there were 1,878,010 shares reserved for future issuance under the 2007 Plan. Both plans are administered by the Compensation Committee of the Board of Directors.

The option price for each stock option granted under either plan may not be less than the fair market value of the Company's common stock on the date of grant. Outstanding stock options are generally exercisable in one-third increments upon the attainment of 10%, 33% and 60% appreciation in the market value of the Company's Class A Common Stock. In addition, options generally vest in one-third increments after three, four and five years, respectively, from the grant date (but, in any event, not until the attainment of the market value thresholds). The options expire on the earlier of ten years from the date of grant, upon employment termination, or within specified time limits following voluntary employment termination (with the consent of the Company), retirement or death. The Company generally settles employee stock option exercises with treasury shares. With respect to outstanding restricted share grants, generally one-half of the shares vest on the third anniversary of the grant. The remaining one-half of the shares vest in one-third increments upon attainment of 10%, 25% and 40% appreciation in the market value of the Company's Class A Common Stock. Unvested restricted shares generally expire on the earlier of five years from the date of grant, upon employment termination, or within specified time limits following voluntary employment termination (with the consent of the Company), retirement or death. The Company issues restricted shares from treasury shares.

For the years ended September 30, 2009, 2008 and 2007, stock-based compensation cost totaled \$5,822, \$4,899 and \$3,509, respectively. The associated future income tax benefit recognized was \$2,270, \$1,911 and \$1,369 for the years ended September 30, 2009, 2008 and 2007, respectively.

The amount of cash received from the exercise of stock options was \$1,206, \$19,192 and \$16,524, for the years ended September 30, 2009, 2008 and 2007, respectively. In connection with these exercises, the tax benefits realized by the Company were \$260, \$5,111 and \$5,976 for the years ended September 30, 2009, 2008 and 2007, respectively.

The transactions for restricted stock for the year ended September 30, 2009 were as follows:

	Shares	Weighted-average grant-date fair value
Non-vested at September 30, 2008	113,121	\$39.05
Granted	160,995	36.64
Vested	(1,200)	43.72
Expired or forfeited	(1,260)	36.41
Non-vested at September 30, 2009	<u>271,656</u>	37.61

As of September 30, 2009, the total unrecognized compensation cost related to unvested restricted stock was \$4,026 which is expected to be recognized over a weighted-average period of 1.6 years.

(Dollar amounts in thousands, except per share data)

9. SHARE-BASED PAYMENTS (continued)

The transactions for shares under options for the year ended September 30, 2009 were as follows:

	Shares	Weighted-average exercise price	Weighted-average remaining contractual term	Aggregate intrinsic value
Outstanding, September 30, 2008	1,366,342	\$35.56		
Granted	—	—		
Exercised	(49,568)	24.33		
Expired or forfeited	(91,865)	36.57		
Outstanding, September 30, 2009	<u>1,224,909</u>	35.94	5.8	\$ —
Exercisable, September 30, 2009	<u>551,874</u>	32.51	4.9	\$1,582

The fair value of option shares earned was \$2,722, \$4,906 and \$4,331 during the years ended September 30, 2009, 2008 and 2007, respectively. The intrinsic value of options (which is the amount by which the stock price exceeded the exercise price of the options on the date of exercise) exercised during the years ended September 30, 2009, 2008 and 2007 was \$753, \$13,422 and \$15,336, respectively.

The transactions for non-vested option shares for the year ended September 30, 2009 were as follows:

	Shares	Weighted-average grant-date fair value
Non-vested at September 30, 2008	1,034,868	\$11.46
Granted	—	—
Vested	(270,818)	10.05
Expired or forfeited	(91,015)	10.40
Non-vested at September 30, 2009	<u>673,035</u>	12.17

As of September 30, 2009, the total unrecognized compensation cost related to non-vested stock options was approximately \$1,213. This cost is expected to be recognized over a weighted-average period of 1.8 years in accordance with the vesting periods of the options.

The fair value of each option and restricted stock grant is estimated on the date of grant using a binomial lattice valuation model. The following table indicates the assumptions used in estimating fair value of stock options (fiscal 2007) and restricted stock (fiscal 2009 and 2008) for the years ended September 30, 2009, 2008 and 2007.

	2009	2008	2007
Expected volatility	27.0%	24.0%	24.0%
Dividend yield	.6%	.6%	.6%
Average risk-free interest rate	2.4%	3.6%	4.7%
Average expected term (years):			
Restricted shares	2.3	2.3	—
Stock options	—	—	6.3

(Dollar amounts in thousands, except per share data)

9. SHARE-BASED PAYMENTS (continued)

The risk-free interest rate is based on United States Treasury yields at the date of grant. The dividend yield is based on the most recent dividend payment and average stock price over the 12 months prior to the grant date. Expected volatilities are based on the historical volatility of the Company's stock price. The expected term for grants in the year ended September 30, 2007 represents an estimate of the period of time options are expected to remain outstanding. The expected term for grants in the years ended September 30, 2009 and 2008 represents an estimate of the average period of time for restricted shares to vest. Separate employee groups and option characteristics are considered separately for valuation purposes.

Under the Company's Director Fee Plan, directors (except for the Chairman of the Board) who are not also officers of the Company each receive, as an annual retainer fee, either cash or shares of the Company's Class A Common Stock equivalent to \$60. The equivalent amount paid to a non-employee Chairman of the Board is \$130. Where the annual retainer fee is provided in shares, each director may elect to be paid these shares on a current basis or have such shares credited to a deferred stock account as phantom stock, with such shares to be paid to the director subsequent to leaving the Board. The value of deferred shares is recorded in other liabilities. A total of 25,013 shares had been deferred under the Director Fee Plan at September 30, 2009. Additionally, directors who are not also officers of the Company each receive an annual stock-based grant (non-statutory stock options, stock appreciation rights and/or restricted shares) with a value of \$70. A total of 22,300 stock options have been granted under the plan. At September 30, 2009, 17,800 options were outstanding and vested. Additionally, 37,210 shares of restricted stock have been granted under the plan, 22,810 of which were unvested at September 30, 2009. A total of 300,000 shares have been authorized to be issued under the Director Fee Plan.

10. EARNINGS PER SHARE:

	2009	2008	2007
Net income	\$57,732	\$79,484	\$64,726
Weighted-average common shares outstanding	30,245,343	30,927,719	31,565,716
Dilutive securities, stock options and restricted stock	189,727	230,584	113,900
Diluted weighted-average common shares outstanding	30,435,070	31,158,303	31,679,616
Basic earnings per share	\$1.91	\$2.57	\$2.05
Diluted earnings per share	\$1.90	\$2.55	\$2.04

Options to purchase 764,650 shares of common stock were not included in the computation of diluted earnings per share for the year ended September 30, 2009 because the inclusion of these options would be anti-dilutive. There were no anti-dilutive securities in the years ended September 30, 2008 and 2007.

(Dollar amounts in thousands, except per share data)

11. PENSION AND OTHER POSTRETIREMENT PLANS:

The Company provides defined benefit pension and other postretirement plans to certain employees. Effective September 30, 2007, the Company adopted the FASB guidance on accounting for defined benefit pension and other postretirement plans. The following provides a reconciliation of benefit obligations, plan assets and funded status of the plans as of the Company's actuarial valuation as of September 30, 2009:

	Pension		Other Postretirement	
	2009	2008	2009	2008
Change in benefit obligation:				
Benefit obligation, beginning	\$108,631	\$111,543	\$ 21,887	\$ 21,819
Effect of change to fiscal year-end valuation	(6,322)	—	(953)	—
Adjusted balance, beginning of year	102,309	111,543	20,934	21,819
Service cost	3,366	4,107	572	585
Interest cost	7,496	7,042	1,542	1,391
Assumption changes	33,600	(6,970)	4,890	943
Actuarial gain	(2,638)	(1,608)	(1,507)	(1,882)
Benefit payments	(5,198)	(5,483)	(781)	(968)
Benefit obligation, ending	138,935	108,631	25,650	21,888
Change in plan assets:				
Fair value, beginning	90,516	87,040	—	—
Effect of change to fiscal year-end valuation	(6,057)	—	—	—
Adjusted balance, beginning of year	84,459	87,040	—	—
Actual return	(7,792)	(7,511)	—	—
Benefit payments	(5,198)	(5,483)	(781)	(968)
Employer contributions	12,959	16,470	781	968
Fair value, ending	84,428	90,516	—	—
Funded status	(54,506)	(18,115)	(25,650)	(21,888)
Unrecognized actuarial loss	72,996	29,462	8,467	6,665
Unrecognized prior service cost	251	283	(1,414)	(2,926)
Net amount recognized	\$ 18,741	\$ 11,630	\$ (18,597)	\$ (18,149)
Amounts recognized in the consolidated balance sheet:				
Current liability	\$ (772)	\$ (907)	\$ (1,051)	\$ (970)
Noncurrent benefit liability	(53,734)	(17,208)	(24,599)	(20,917)
Accumulated other comprehensive loss	73,247	29,745	7,053	3,738
Net amount recognized	\$ 18,741	\$ 11,630	\$ (18,597)	\$ (18,149)
Amounts recognized in accumulated other comprehensive loss:				
Net actuarial loss	\$ 72,996	\$ 29,462	\$ 8,467	\$ 6,665
Prior service cost	251	283	(1,414)	(2,926)
Net amount recognized	\$ 73,247	\$ 29,745	\$ 7,053	\$ 3,739

(Dollar amounts in thousands, except per share data)

11. PENSION AND OTHER POST-RETIREMENT PLANS (continued)

Based upon actuarial valuations performed as of September 30, 2009 and July 31, 2008 (plan year-end), the accumulated benefit obligation for the Company's defined benefit pension plans was \$120,825 and \$95,703 at September 30, 2009 and 2008, respectively, and the projected benefit obligation for the Company's defined benefit pension plans was \$138,935 and \$108,631 at September 30, 2009 and 2008, respectively.

Net periodic pension and other postretirement benefit cost for the plans included the following:

	Pension			Other Postretirement		
	2009	2008	2007	2009	2008	2007
Service cost	\$3,366	\$4,107	\$3,892	\$ 572	\$ 585	\$ 533
Interest cost	7,496	7,042	6,525	1,542	1,391	1,188
Expected return on plan assets	(7,593)	(7,454)	(6,410)	—	—	—
Amortization:						
Prior service cost	28	28	31	(1,297)	(1,287)	(1,287)
Net actuarial loss	1,759	1,220	1,527	294	486	288
Net benefit cost	\$5,056	\$4,943	\$5,565	\$1,111	\$1,175	\$ 722

Benefit payments under the Company's principal retirement plan are made from plan assets, while benefit payments under the supplemental retirement plan and postretirement benefit plan are made from the Company's operating cash. Under IRS regulations, the Company was not required to make any significant contributions to its principal retirement plan in fiscal 2009, however, the Company made a contribution of \$12,000 to its principal retirement plan. The Company is not required to make any significant contributions to its principal retirement plan in fiscal 2010. Contributions of \$835 and \$781 were made under the Company's supplemental retirement plan and postretirement benefit plan, respectively, in fiscal 2009.

Amounts of AOCL expected to be recognized in net periodic benefit costs in fiscal 2010 include:

	Pension Benefits	Other Postretirement Benefits
Net actuarial gain/loss	\$ 5,406	\$521
Prior service cost	24	726

(Dollar amounts in thousands, except per share data)

11. PENSION AND OTHER POST-RETIREMENT PLANS (continued)

The measurement date of annual actuarial valuations for the Company's principal retirement and other postretirement benefit plans was September 30 for fiscal 2009, and was July 31 (plan year-end) for fiscal 2008 and 2007. The weighted-average assumptions for those plans were:

	Pension			Other Postretirement		
	2009	2008	2007	2009	2008	2007
Discount rate	5.50%	7.00%	6.50%	5.50%	7.00%	6.50%
Return on plan assets	8.50	8.50	9.00	—	—	—
Compensation increase	4.25	4.25	4.25	—	—	—

The Company's principal pension plan maintains a substantial portion of its assets in equity securities in accordance with the investment policy established by the Company's pension board. Based on an analysis of the historical performance of the plan's assets and information provided by its independent investment advisor, the Company set the long-term rate of return assumption for these assets at 8.5% in 2009 for purposes of determining pension cost and funded status under current guidance. The Company's discount rate assumption used in determining the present value of the projected benefit obligation is based upon published indices.

Benefit payments expected to be paid are as follows:

Years ending September 30:	Pension Benefits	Other Postretirement Benefits
2010	\$ 5,320	\$ 1,051
2011	5,614	1,163
2012	5,957	1,255
2013	6,244	1,379
2014	6,612	1,530
2015-2019	39,514	9,669
	\$69,261	\$16,047

For measurement purposes, a rate of increase of 8% in the per capita cost of health care benefits was assumed for 2010; the rate was assumed to decrease gradually to 5.0% for 2030 and remain at that level thereafter. Assumed health care cost trend rates have a significant effect on the amounts reported. An increase in the assumed health care cost trend rates by one percentage point would have increased the accumulated postretirement benefit obligation as of September 30, 2009 by \$1,418 and the aggregate of the service and interest cost components of net periodic postretirement benefit cost for the year then ended by \$144. A decrease in the assumed health care cost trend rates by one percentage point would have decreased the accumulated postretirement benefit obligation as of September 30, 2009 by \$1,250 and the aggregate of the service and interest cost components of net periodic postretirement benefit cost for the year then ended by \$126.

(Dollar amounts in thousands, except per share data)

12. INCOME TAXES:

The provision for income taxes consisted of the following:

	2009	2008	2007
Current:			
Federal	\$15,896	\$22,270	\$20,941
State	1,584	4,735	2,762
Foreign	5,461	7,813	7,461
	22,941	34,818	31,164
Statutory rate changes	—	(1,882)	—
Deferred	7,870	9,152	7,826
Total	\$30,811	\$42,088	\$38,990
		2009	2008
Deferred tax assets:			
Postretirement benefits		\$10,014	\$ 8,536
Environmental reserve		2,854	3,215
Pension costs		20,463	6,271
Deferred compensation		1,752	2,646
Stock options		5,361	3,714
Other		16,772	14,082
		57,216	38,464
Deferred tax liabilities:			
Depreciation		(365)	(1,647)
Goodwill		(35,605)	(28,426)
Other		(331)	—
		(36,301)	(30,073)
Net deferred tax asset		\$20,915	\$ 8,391

The reconciliation of the federal statutory tax rate to the consolidated effective tax rate was as follows:

	2009	2008	2007
Federal statutory tax rate	35.0%	35.0%	35.0%
Effect of state income taxes, net of federal deduction	2.9	3.2	2.2
Foreign taxes (less than) in excess of federal statutory rate	(1.4)	(0.5)	.5
Changes in statutory tax rates	—	(1.5)	—
Other	(1.7)	(1.6)	(0.1)
Effective tax rate	34.8%	34.6%	37.6%

The Company's foreign subsidiaries had income before income taxes for the years ended September 30, 2009, 2008 and 2007 of approximately \$24,815, \$24,326 and \$24,300, respectively. At September 30, 2009, undistributed earnings of foreign subsidiaries for which deferred U.S. income taxes have not been provided approximated \$120,540.

(Dollar amounts in thousands, except per share data)

12. INCOME TAXES (continued)

On October 1, 2007, the Company adopted FASB guidance on uncertainty in income taxes which clarifies the accounting for uncertainty in income taxes recognized in an enterprise's financial statements. This guidance prescribes a recognition threshold and measurement attribute for the financial statement recognition and measurement of a tax position taken or expected to be taken in a tax return and provides guidance on recognition, classification, interest and penalties, accounting in interim periods, disclosures and transition. The adoption of this guidance did not have a material effect on the Company's financial statements.

Changes in the total amount of gross unrecognized tax benefits (excluding penalties and interest) are as follows:

Balance at September 30, 2008	\$4,370
Increases for tax positions of prior years	120
Decreases for tax positions of prior years	(607)
Increases based on tax positions related to the current year	674
Decreases due to settlements with taxing authorities	(542)
Decreases due to lapse of statute of limitation	(440)
	<hr/>
Balance at September 30, 2009	<u>\$3,575</u>

The Company had unrecognized tax benefits of \$3,575 and \$4,370 at September 30, 2009 and 2008, respectively, all of which, if recorded, would impact the annual effective tax rate. It is reasonably possible that the amount of unrecognized tax benefits could change by approximately \$406 in the next 12 months primarily due to expiration of statutes related to specific tax positions.

The Company classifies interest and penalties on tax uncertainties as a component of the provision for income taxes. For fiscal 2009, the Company included a net increase of \$64 in interest and penalties as a component of the provision for income taxes. Total penalties and interest accrued were \$2,838 and \$2,774 at September 30, 2009 and 2008, respectively. These accruals may potentially be applicable in the event of an unfavorable outcome of uncertain tax positions.

The Company is currently under examination in several tax jurisdictions and remains subject to examination until the statute of limitation expires for those tax jurisdictions. As of September 30, 2009, the tax years that remain subject to examination by major jurisdiction generally are:

United States - Federal	2007 and forward
United States - State	2006 and forward
Canada	2004 and forward
Europe	2002 and forward
United Kingdom	2008 and forward
Australia	2005 and forward

13. COMMITMENTS AND CONTINGENT LIABILITIES:

The Company operates various production, warehouse and office facilities and equipment under operating lease agreements. Annual rentals under these and other operating leases were \$14,881, \$16,938 and \$15,621 in fiscal 2009, 2008 and 2007, respectively. Future minimum rental commitments under non-cancelable operating lease arrangements for fiscal years 2010 through 2014 are \$8,070, \$5,933, \$3,850, \$2,115 and \$902, respectively, and \$596 thereafter.

The Company is party to various legal proceedings, the eventual outcome of which are not predictable. Although the ultimate disposition of these proceedings is not presently determinable, management is of the opinion that they should not result in liabilities in an amount which would materially affect the Company's consolidated financial position, results of operations or cash flows.

(Dollar amounts in thousands, except per share data)

13. COMMITMENTS AND CONTINGENT LIABILITIES (continued)

The Company has employment agreements with certain employees, the terms of which expire at various dates between 2009 and 2013. The agreements generally provide for base salary and bonus levels and include non-compete provisions. The aggregate commitment for salaries under these agreements at September 30, 2009 was \$6,676.

14. ENVIRONMENTAL MATTERS:

The Company's operations are subject to various federal, state and local laws and regulations relating to the protection of the environment. These laws and regulations impose limitations on the discharge of materials into the environment and require the Company to obtain and operate in compliance with conditions of permits and other government authorizations. As such, the Company has developed environmental, health and safety policies and procedures that include the proper handling, storage and disposal of hazardous materials.

The Company is party to various environmental matters. These include obligations to investigate and mitigate the effects on the environment of the disposal of certain materials at various operating and non-operating sites. The Company is currently performing environmental assessments and remediation at these sites, as appropriate. In addition, prior to its acquisition, The York Group, Inc. ("York") was identified, along with others, by the Environmental Protection Agency as a potentially responsible party for remediation of a landfill site in York, Pennsylvania. At this time, the Company has not been joined in any lawsuit or administrative order related to the site or its clean-up.

At September 30, 2009, an accrual of \$7,318 had been recorded for environmental remediation (of which \$836 was classified in other current liabilities), representing management's best estimate of the probable and reasonably estimable costs of the Company's known remediation obligations. The accrual, which reflects previously established reserves assumed with the acquisition of York and additional reserves recorded as a purchase accounting adjustment, does not consider the effects of inflation and anticipated expenditures are not discounted to their present value. While final resolution of these contingencies could result in costs different than current accruals, management believes the ultimate outcome will not have a significant effect on the Company's consolidated results of operations or financial position.

15. SUPPLEMENTAL CASH FLOW INFORMATION:

Changes in working capital items as presented in the Consolidated Statements of Cash Flows consisted of the following:

	2009	2008	2007
Current assets:			
Accounts receivable	\$ 8,828	\$(6,677)	\$ 1,502
Inventories	4,751	9,361	(2,135)
Other current assets	(2,940)	(1,729)	(2,567)
	<u>10,639</u>	<u>955</u>	<u>(3,200)</u>
Current liabilities:			
Trade accounts payable	1,444	(1,418)	1,064
Accrued compensation	(4,791)	6,314	(2,411)
Accrued income taxes	(4,104)	4,601	(3,644)
Customer prepayments	(974)	(2,397)	514
Other current liabilities	(4,547)	(9,848)	(6,696)
	<u>(12,972)</u>	<u>(2,748)</u>	<u>(11,173)</u>
Net change	<u>\$ (2,333)</u>	<u>\$(1,793)</u>	<u>\$(14,373)</u>

(Dollar amounts in thousands, except per share data)

16. SEGMENT INFORMATION:

The Company's products and operations consist of two principal businesses that are comprised of three operating segments each, as described under Nature of Operations (Note 1): Memorialization Products (Bronze, Casket, Cremation) and Brand Solutions (Graphics Imaging, Marking Products, Merchandising Solutions). Management evaluates segment performance based on operating profit (before income taxes) and does not allocate non-operating items such as investment income, interest expense, other income (deductions), net and minority interest.

The accounting policies of the segments are the same as those described in Summary of Significant Accounting Policies (Note 2). Intersegment sales are accounted for at negotiated prices. Operating profit is total revenue less operating expenses. Segment assets include those assets that are used in the Company's operations within each segment. Assets classified under "Other" principally consist of cash and cash equivalents, investments, deferred income taxes and corporate headquarters' assets. Long-lived assets include property, plant and equipment (net of accumulated depreciation), goodwill, and other intangible assets (net of accumulated amortization).

Information about the Company's segments follows:

	MEMORIALIZATION			BRAND SOLUTIONS				Consolidated
	Bronze	Casket	Cremation	Graphics Imaging	Marking Products	Merchandising Solutions	Other	
Sales to external customers:								
2009	\$215,934	\$203,247	\$30,909	\$234,966	\$42,355	\$53,497	\$ —	\$780,908
2008	243,063	219,792	26,665	203,703	60,031	65,369	—	818,623
2007	229,850	210,673	25,166	146,049	57,450	80,164	—	749,352
Intersegment sales:								
2009	192	276	4,182	64	30	34	—	4,778
2008	213	542	3,883	30	32	45	—	4,745
2007	208	220	2,594	13	41	41	—	3,117
Depreciation and amortization:								
2009	4,136	7,081	251	14,677	614	2,088	1,445	30,292
2008	3,182	7,840	179	9,716	691	2,433	894	24,935
2007	3,707	6,680	164	5,431	630	2,896	1,020	20,528
Operating profit:								
2009	57,598	17,716	5,036	19,217	1,500	(56)	—	101,011
2008	71,576	23,339	5,474	18,617	9,137	4,809	—	132,952
2007	66,298	11,801	3,631	14,439	9,931	5,724	—	111,824
Total assets:								
2009	182,194	253,012	22,541	337,407	39,569	51,492	63,438	949,653
2008	168,050	264,607	11,990	339,308	48,514	56,714	25,099	914,282
2007	158,666	280,598	11,910	180,987	42,851	59,436	36,621	771,069
Capital expenditures:								
2009	3,017	2,648	138	8,011	251	492	4,853	19,410
2008	1,369	1,672	130	6,158	365	489	1,870	12,053
2007	3,557	5,811	170	3,850	545	6,426	290	20,649

(Dollar amounts in thousands, except per share data)

16. SEGMENT INFORMATION (continued)

Information about the Company's operations by geographic area follows:

	United States	Mexico	Canada	Europe	Australia	Asia	Consolidated
Sales to external customers:							
2009	\$498,782	\$ —	\$11,995	\$251,823	\$ 9,647	\$8,661	\$780,908
2008	562,991	—	14,122	221,378	11,801	8,331	818,623
2007	563,594	—	14,475	158,651	9,969	2,663	749,352
Long-lived assets:							
2009	303,342	5,685	466	256,271	3,987	8,529	578,280
2008	304,614	5,588	469	247,310	2,673	4,635	565,289
2007	312,694	6,377	504	131,786	3,066	4,103	458,530

17. ACQUISITIONS:**Fiscal 2009:**

Acquisition spending, net of cash acquired, during the year ended September 30, 2009 totaled \$11.0 million. The acquisitions were not individually, or in the aggregate, material to the Company's consolidated financial position or results of operations.

Fiscal 2008:

Acquisition spending, net of cash acquired, during the year ended September 30, 2008 totaled \$98,070, and primarily included the following:

In September 2008, the Company acquired the remaining 20% interest in S+T Gesellschaft fur Reprotechnik GmbH ("S+T GmbH"). The Company had acquired a 50% interest in S+T GmbH in 1998 and a 30% interest in 2005.

In May 2008, the Company acquired a 78% interest in Saueressig, a manufacturer of gravure printing cylinders. Saueressig is headquartered in Vreden, Germany and has its principal manufacturing operations in Germany, Poland and the United Kingdom. The transaction was structured as a stock purchase with a purchase price of approximately 58.1 million Euros (\$90,783). The cash portion of the transaction was funded principally through borrowings under the Company's existing credit facilities. The acquisition was designed to expand Matthews' products and services in the global graphics imaging market.

In addition, the Company entered into an option agreement related to the remaining 22% interest in Saueressig. The option agreement contains certain put and call provisions for the purchase of the remaining 22% interest in future years at a price to be determined by a specified formula based on future operating results of Saueressig. The initial carrying value of minority interest was adjusted to the estimated future purchase price ("Redemption Value") of the minority interest, with a corresponding charge to retained earnings. For subsequent periods, the carrying value of minority interest reflected on the Company's balance sheet will be adjusted for changes in Redemption Value, with a corresponding adjustment to retained earnings. To the extent Redemption Value in future periods is less than or greater than the estimated fair value of the minority interest, income available to common shareholders in the determination of earnings per share will increase or decrease, respectively, by such amount. However, income available to common shareholders will only increase to the extent that a decrease was previously recognized. In any case, net income will not be affected by such amounts. At September 30, 2009, Redemption Value was equal to fair value, and there was no impact on income available to common shareholders.

(Dollar amounts in thousands, except per share data)

17. ACQUISITIONS (continued)

The Company has made an assessment of the fair value in all material respects of the assets acquired and liabilities assumed in the Saueressig acquisition. Operating results of the acquired business have been included in the consolidated statement of income from the acquisition date forward.

The following table summarizes the fair value of major assets and liabilities of Saueressig at the date of acquisition.

Cash	\$ 504
Trade receivables	22,324
Inventory	11,500
Other current assets	1,013
Property, plant and equipment	68,493
Goodwill	55,789
Intangible assets	14,287
Other assets	3,581
Total assets acquired	<u>177,491</u>
Trade accounts payable	5,016
Debt	53,714
Other liabilities	25,458
Minority interest	2,520
Total liabilities assumed	<u>86,708</u>
Net assets acquired	<u><u>\$ 90,783</u></u>

The estimated fair value of the acquired intangible assets of Saueressig include trade names with an assigned value of \$1,705, customer relationships with an assigned value of \$11,584, and technology and non-compete values of approximately \$998. The intangible assets will be amortized between 2 and 20 years.

The following unaudited pro-forma information presents a summary of the consolidated results of Matthews combined with Saueressig as if the acquisition had occurred on October 1, 2007:

	<u>2009</u>	<u>2008</u>
Sales	\$780,908	\$901,001
Income before income taxes	88,543	120,162
Net income	57,732	78,353
Earnings per share	\$1.90	\$2.52

These unaudited pro forma results have been prepared for comparative purposes only and include certain adjustments, such as interest expense on acquisition debt. The pro forma information does not purport to be indicative of the results of operations which actually would have resulted had the acquisition occurred on the date indicated, or which may result in the future.

(Dollar amounts in thousands, except per share data)

17. ACQUISITIONS (continued)

Fiscal 2007:

Acquisition spending, net of cash acquired, during the year ended September 30, 2007 totaled \$23,784, and primarily included the following:

In July 2007, York reached a settlement agreement with Yorktowne Caskets, Inc. and its shareholders (collectively "Yorktowne") with respect to all outstanding litigation between the parties. In exchange for the mutual release, the principal terms of the settlement included the assignment by Yorktowne of certain customer and employment-related contracts to York and the purchase by York of certain assets, including York-product inventory, of Yorktowne.

In June 2007, the Company acquired a 60% interest in Beijing Kenuohua Electronic Technology Co., Ltd., ("Kenuohua"), an ink-jet equipment manufacturer, headquartered in Beijing, China. The acquisition was structured as a stock purchase. The acquisition was intended to expand Matthews' marking products manufacturing and distribution capabilities in Asia.

In December 2006, the Company paid additional purchase consideration of \$7,000 under the terms of the Milso Industries ("Milso") acquisition agreement.

Matthews has accounted for these acquisitions using the purchase method and, accordingly, recorded the acquired assets and liabilities at their estimated fair values at the acquisition dates. The excess of the purchase price over the estimated fair value of the net assets acquired was recorded as goodwill.

18. DISPOSITION:

In August 2007, the Company sold its marketing consultancy business. The transaction resulted in a pre-tax gain of \$1,322, which was recorded as a reduction in administrative expenses in the Consolidated Statement of Income.

19. GOODWILL AND OTHER INTANGIBLE ASSETS:

Goodwill is not amortized but is subject to annual review for impairment. In general, when the carrying value of a reporting unit exceeds its implied fair value, an impairment loss must be recognized. For purposes of testing for impairment the Company uses a combination of valuation techniques, including discounted cash flows. Intangible assets are amortized over their estimated useful lives unless such lives are considered to be indefinite. A significant decline in cash flows generated from these assets may result in a write-down of the carrying values of the related assets.

(Dollar amounts in thousands, except per share data)

19. GOODWILL AND OTHER INTANGIBLE ASSETS (continued)

The Company performed its annual impairment reviews in the second quarters of fiscal 2009 and fiscal 2008 and determined that no adjustments to the carrying values of goodwill or other indefinite lived intangibles were necessary. Changes to goodwill, net of accumulated amortization, during the years ended September 30, 2009 and 2008, follow.

	Bronze	Casket	Cremation	Graphics Imaging	Marking Products	Merchandising Solutions	Consolidated
Balance at September 30, 2007	\$77,375	\$120,555	\$6,536	\$ 95,632	\$9,062	\$9,138	\$318,298
Additions	—	882	—	41,865	151	—	42,898
Dispositions	—	—	—	(160)	—	—	(160)
Translation and adjustments	(588)	—	—	(1,183)	376	—	(1,395)
Balance at September 30, 2008	76,787	121,437	6,536	136,154	9,589	9,138	359,641
Additions	1,266	1,459	2,041	17,685	379	—	22,830
Translation and adjustments	1,242	—	310	1,184	12	—	2,748
Balance at September 30, 2009	\$79,295	\$122,896	\$8,887	\$155,023	\$9,980	\$9,138	\$385,219

In 2009, the addition to Bronze goodwill reflects the acquisition of a small bronze manufacturer in Europe; the addition to Casket goodwill reflects the acquisition of a small casket distributor in the United States; the addition to Cremation goodwill reflects the acquisition of a small cremation equipment manufacturer in Europe; the addition to Graphics Imaging goodwill principally represents the effect of final adjustments to the allocation of purchase price for the Saueressig acquisition; and the addition to Marking Products goodwill reflects the acquisition of a small distributor in Europe.

In 2008, the addition to Graphics Imaging relates to the purchase of a 78% interest in Saueressig which is expected to be deductible for tax purposes, and the remaining 20% interest in S+T GmbH. The additions to Casket goodwill during fiscal 2008 related primarily to additional consideration paid in accordance with the purchase agreement with Royal Casket Company.

(Dollar amounts in thousands, except per share data)

19. GOODWILL AND OTHER INTANGIBLE ASSETS (continued)

The following tables summarize the carrying amounts and related accumulated amortization for intangible assets as of September 30, 2009 and 2008, respectively.

	Carrying Amount	Accumulated Amortization	Net
September 30, 2009:			
Trade names	\$24,418	\$ — *	\$24,418
Trade names	1,598	(458)	1,140
Customer relationships	35,568	(8,232)	27,336
Copyrights/patents/other	7,777	(5,670)	2,107
	<u>\$69,361</u>	<u>\$(14,360)</u>	<u>\$55,001</u>
September 30, 2008:			
Trade names	\$25,109	\$ — *	\$25,109
Trade names	2,822	(145)	2,677
Customer relationships	34,477	(5,720)	28,757
Copyrights/patents/other	7,885	(4,518)	3,367
	<u>\$70,293</u>	<u>\$(10,383)</u>	<u>\$59,910</u>

*Not subject to amortization.

The increase in intangible assets during fiscal 2009 was due to the addition of intellectual property in the Bronze and Marking Products segments, and the impact of fluctuations in foreign currency exchange rates on intangible assets denominated in foreign currencies, offset by additional amortization. The increase in intangible assets during fiscal 2008 was due to the acquisition of Saueressig.

Amortization expense on intangible assets was \$4,310, \$3,536, and \$2,129 in fiscal 2009, 2008 and 2007, respectively. Fiscal year amortization expense is estimated to be \$3,227 in 2010, \$2,888 in 2011, \$2,473 in 2012, \$2,203 in 2013, and \$2,035 in 2014.

20. ACCOUNTING PRONOUNCEMENTS:

On September 30, 2009, the Company adopted changes issued by the FASB to the authoritative hierarchy of generally accepted accounting principles ("GAAP"). These changes establish the FASB Accounting Standards Codification™ ("Codification") as the source of authoritative accounting principles recognized by the FASB to be used in the preparation of financial statements of nongovernmental entities that are presented in conformity with GAAP in the U.S. The Codification is effective for financial statements issued for interim and annual periods ending after September 15, 2009. The adoption had no material impact on the Company's consolidated results of operations or financial condition.

The Company adopted changes issued by the FASB regarding accounting for income tax benefits of dividends on share-based payment awards on October 1, 2008. The changes require that tax benefits generated by dividends on equity classified non-vested equity shares, non-vested equity share units, and outstanding equity share options be classified as additional paid-in capital and included in a pool of excess tax benefits available to absorb tax deficiencies from share-based payment awards. The adoption had no material impact on the Company's consolidated results of operations or financial condition.

(Dollar amounts in thousands, except per share data)

20. ACCOUNTING PRONOUNCEMENTS (continued)

In December 2007, the FASB issued new guidance regarding business combinations. This guidance requires recognition and measurement of the identifiable assets acquired, the liabilities assumed, and any noncontrolling interest in a business combination, goodwill acquired or a gain from a bargain purchase. It is effective for fiscal years beginning on or after December 15, 2008 and is to be applied prospectively. Earlier adoption is not permitted. The Company is currently evaluating the impact of the adoption of this guidance.

In December 2007, the FASB issued new guidance regarding noncontrolling interests in consolidated financial statements. This guidance establishes accounting and reporting standards for the noncontrolling interest in a subsidiary. It requires that consolidated net income reflect the amounts attributable to both the parent and the noncontrolling interest, and also includes additional disclosure requirements. It is effective for fiscal years beginning on or after December 15, 2008 and is to be applied prospectively as of the beginning of the fiscal year in which the guidance is initially applied, except for the presentation and disclosure requirements which shall be applied retrospectively for all periods presented. Earlier adoption is not permitted. The Company is currently evaluating the impact of the adoption of this guidance.

In December 2008, the FASB issued changes to employers' disclosures about postretirement benefit plan assets. These changes require enhanced disclosures regarding assets in defined benefit pension or other postretirement plans. It is effective for fiscal years ending after December 31, 2009. Earlier application is permitted. The Company is currently evaluating the impact of the adoption of these changes.

In April 2009, the FASB issued changes to require disclosures about fair value of financial instruments for interim reporting periods of publicly traded companies as well as in annual financial statements. It also requires those disclosures in summarized financial information at interim reporting periods. These changes are effective for interim reporting periods ending after June 15, 2009 and were adopted by the Company as of June 30, 2009. See Notes 3 and 7.

Effective September 30, 2007, the Company adopted the recognition and related disclosure provisions of guidance on employers' accounting for defined benefit pension and other postretirement plans which amended earlier guidance. In the first quarter of fiscal 2009, the Company adopted the provision requiring the Company to measure the plan assets and benefit obligations of defined benefit postretirement plans as of the date of its year-end balance sheet. Adoption of this provision did not have a material effect on the Company's consolidated results of operations or financial condition. See Note 11.

In May 2009, the FASB issued new guidance regarding subsequent events. The guidance establishes general standards of accounting for and disclosure of events that occur after the balance sheet date but before financial statements are issued or are available to be issued. The statement is effective for interim or annual financial periods ending after June 15, 2009. Accordingly, the Company adopted these changes as of June 30, 2009. The adoption had no material impact on the Company's consolidated results of operations or financial condition. See Note 21.

In June 2008, the FASB issued guidance regarding instruments granted in share-based payments. The guidance requires unvested share-based payment awards that contain non-forfeitable rights to dividends or dividend equivalents (whether paid or unpaid) to be considered participating securities and therefore included in the computation of earnings per share pursuant to the two-class method. This guidance is effective for years beginning after December 31, 2008. The Company is currently evaluating the impact of the adoption of these changes.

21. SUBSEQUENT EVENTS:

The Company evaluated subsequent events for recognition and disclosure through November 23, 2009. The evaluation resulted in no impact to the consolidated financial statements.

SUPPLEMENTARY FINANCIAL INFORMATION

Selected Quarterly Financial Data (Unaudited):

The following table sets forth certain items included in the Company's unaudited consolidated financial statements for each quarter of fiscal 2009 and fiscal 2008.

	Quarter Ended				Year Ended September 30
	December 31	March 31	June 30	September 30	
(Dollar amounts in thousands, except per share data)					
FISCAL YEAR 2009:					
Sales	\$191,286	\$197,362	\$192,047	\$200,213	\$780,908
Gross profit	67,852	73,117	75,466	78,342	294,777
Operating profit	20,079	23,439	29,810	27,683	101,011
Net income	11,289	12,742	18,068	15,633	57,732
Earnings per share	\$.37	\$.42	\$.60	\$.52	\$1.90
FISCAL YEAR 2008:					
Sales	\$182,348	\$197,827	\$219,270	\$219,178	\$818,623
Gross profit	71,988	80,234	86,919	83,823	322,964
Operating profit	26,778	34,392	36,734	35,048	132,952
Net income	17,431	20,283	21,378	20,392	79,484
Earnings per share	\$.56	\$.65	\$.69	\$.66	\$2.55

FINANCIAL STATEMENT SCHEDULE

SCHEDULE II — VALUATION AND QUALIFYING ACCOUNTS

Description	Balance at beginning of period	Additions		Deductions ²	Balance at end of period
		Charged to expense	Charged to other accounts ¹		
(Dollar amounts in thousands)					
Allowance for Doubtful Accounts:					
Fiscal Year Ended:					
September 30, 2009	\$11,538	\$4,320	\$ —	\$(3,228)	\$12,630
September 30, 2008	11,160	1,712	885	(2,219)	11,538
September 30, 2007	10,829	335	209	(213)	11,160

¹Amount comprised principally of acquisitions and purchase accounting adjustments in connection with acquisitions.

²Amounts determined not to be collectible (including direct write-offs), net of recoveries.

ITEM 9. CHANGES IN AND DISAGREEMENTS WITH ACCOUNTANTS ON ACCOUNTING AND FINANCIAL DISCLOSURE.

There have been no changes in accountants or disagreements on accounting or financial disclosure between the Company and PricewaterhouseCoopers LLP, Independent Registered Public Accounting Firm, for the fiscal years ended September 30, 2009, 2008 and 2007.

ITEM 9A. CONTROLS AND PROCEDURES.

(a) Evaluation of Disclosure Controls and Procedures.

The Company's disclosure controls and procedures (as defined in Rules 13a-15(e) and 15d-15(e) under the Securities Exchange Act of 1934, as amended) are designed to provide reasonable assurance that information required to be disclosed in the Company's reports filed under that Act (the "Exchange Act"), such as this Annual Report on Form 10-K, is recorded, processed, summarized and reported within the time periods specified in the rules of the Securities and Exchange Commission. These disclosure controls and procedures also are designed to provide reasonable assurance that such information is accumulated and communicated to management, including the Chief Executive Officer and Chief Financial Officer, to allow timely decisions regarding required disclosures.

Management, under the supervision and with the participation of our Chief Executive Officer and the Chief Financial Officer, evaluated the effectiveness of the Company's disclosure controls and procedures in effect as of September 30, 2009. Based on that evaluation, the Chief Executive Officer and Chief Financial Officer concluded that, as of September 30, 2009, the Company's disclosure controls and procedures were effective to provide reasonable assurance that material information is accumulated and communicated to management, including the Chief Executive Officer and Chief Financial Officer, and that such information is recorded, processed, summarized and properly reported within the appropriate time period, relating to the Company and its consolidated subsidiaries, required to be included in the Exchange Act reports, including this Annual Report on Form 10-K.

(b) Management's Report on Internal Control over Financial Reporting.

Management's Report on Internal Control over Financial Reporting is included in Management's Report to Shareholders in Item 8 of this Annual Report on Form 10-K.

(c) Attestation Report of the Registered Public Accounting Firm.

The Company's internal control over financial reporting as of September 30, 2009 has been audited by PricewaterhouseCoopers LLP, an independent registered public accounting firm, as stated in their report which is included in Item 8 of this Annual Report on Form 10-K.

(d) Changes in Internal Control over Financial Reporting.

There have been no changes in the Company's internal controls over financial reporting that occurred during the fourth fiscal quarter ended September 30, 2009 that have materially affected, or are reasonably likely to materially affect, the Company's internal controls over financial reporting.

PART III

ITEM 10. DIRECTORS, OFFICERS and EXECUTIVE MANAGEMENT OF THE REGISTRANT.

In addition to the information reported in Part I of this Form 10-K, under the caption "Officers and Executive Management of the Registrant", the information required by this item as to the directors of the Company is hereby incorporated by reference from the information appearing under the captions "General Information Regarding Corporate Governance – Audit Committee", "Proposal No. 1 – Elections of Directors", and "Compliance with Section 16(a) of the Exchange Act" in the Company's definitive proxy statement, which involves the election of the directors and is to be filed with the Securities and Exchange Commission pursuant to the Exchange Act of 1934, as amended, within 120 days of the end of the Company's fiscal year ended September 30, 2009.

The Company's Code of Ethics Applicable to Executive Management is set forth in Exhibit 14.1 hereto.

ITEM 11. EXECUTIVE COMPENSATION.

The information required by this item as to the compensation of directors and executive management of the Company is hereby incorporated by reference from the information appearing under the captions "Compensation of Directors" and "Executive Compensation and Retirement Benefits" in the Company's definitive proxy statement which involves the election of directors and is to be filed with the Commission pursuant to the Exchange Act, within 120 days of the end of the Company's fiscal year ended September 30, 2009. The information contained in the "Compensation Committee Report" is specifically not incorporated herein by reference.

ITEM 12. SECURITY OWNERSHIP OF CERTAIN BENEFICIAL OWNERS AND MANAGEMENT.

The information required by this item as to the ownership by management and others of securities of the Company is hereby incorporated by reference from the information appearing under the caption "Stock Ownership" in the Company's definitive proxy statement which involves the election of directors and is to be filed with the Commission pursuant to the Exchange Act, within 120 days of the end of the Company's fiscal year ended September 30, 2009.

Equity Compensation Plans:

The Company maintains a stock incentive plan (the "1992 Incentive Stock Plan") that provided for grants of stock options, restricted shares and certain other types of stock-based awards. In February 2008, the Company's shareholders approved the adoption of a new plan, the 2007 Equity Incentive Plan (the "2007 Plan"), that provides for the grants of stock options, restricted shares, stock-based performance units and certain other types of stock-based awards. Under the 2007 Plan, which has a ten-year term, the maximum number of shares available for grants or awards is an aggregate of 2,200,000. There will be no further grants under the 1992 Incentive Stock Plan. At September 30, 2009, there were 1,878,010 shares reserved for future issuance under the 2007 Plan. Both plans are administered by the Compensation Committee of the Board of Directors.

The option price for each stock option granted under either plan may not be less than the fair market value of the Company's common stock on the date of grant. Outstanding stock options are generally exercisable in one-third increments upon the attainment of 10%, 33% and 60% appreciation in the market value of the Company's Class A Common Stock. In addition, options generally vest in one-third increments after three, four and five years, respectively, from the grant date (but, in any event, not until the attainment of the market value thresholds). The options expire on the earlier of ten years from the date of grant, upon employment termination, or within specified time limits following voluntary employment termination (with the consent of the Company), retirement or death. The Company generally settles employee stock option exercises with treasury shares. With respect

to outstanding restricted share grants, generally one-half of the shares vest on the third anniversary of the grant. The remaining one-half of the shares vest in one-third increments upon attainment of 10%, 25% and 40% appreciation in the market value of the Company's Class A Common Stock. Unvested restricted shares generally expire on the earlier of five years from the date of grant, upon employment termination, or within specified time limits following voluntary employment termination (with the consent of the Company), retirement or death. The Company issues restricted shares from treasury shares.

Under the Company's Director Fee Plan, directors (except for the Chairman of the Board) who are not also officers of the Company each receive, as an annual retainer fee, either cash or shares of the Company's Class A Common Stock equivalent to \$60,000. The equivalent amount paid to a non-employee Chairman of the Board is \$130,000. Where the annual retainer fee is provided in shares, each director may elect to be paid these shares on a current basis or have such shares credited to a deferred stock account as phantom stock, with such shares to be paid to the director subsequent to leaving the Board. The value of deferred shares is recorded in other liabilities. A total of 25,013 shares had been deferred under the Director Fee Plan at September 30, 2009. Additionally, directors who are not also officers of the Company each receive an annual stock-based grant (non-statutory stock options, stock appreciation rights and/or restricted shares) with a value of \$70,000. A total of 22,300 stock options have been granted under the plan. At September 30, 2009, 17,800 options were outstanding and vested. Additionally, 37,210 shares of restricted stock have been granted under the plan, 22,810 of which were unvested at September 30, 2009. A total of 300,000 shares have been authorized to be issued under the Director Fee Plan.

The following table provides information about grants under the Company's equity compensation plans as of September 30, 2009:

Equity Compensation Plan Information

Plan category	Number of securities to be issued upon exercise of outstanding options, warrants and rights	Weighted-average exercise price of outstanding options, warrants and rights	Number of securities remaining available for future issuance under equity compensation plans (excluding securities reflected in column (a))
	(a)	(b)	(c)
Equity compensation plans approved by security holders:			
1992 Stock Incentive Plan	1,224,909	\$35.94	— ¹
2007 Equity Incentive Plan	—	—	1,878,010 ²
Employee Stock Purchase Plan	—	—	1,694,672 ³
Director Fee Plan	42,813	35.13	155,077 ⁴
Equity compensation plans not approved by security holders	None	None	None
Total	1,267,722	\$35.93	3,727,759

¹ As a result of the approval of the 2007 Equity Incentive Plan, no further grants or awards will be made under the 1992 Incentive Stock Plan.

² The 2007 Equity Incentive Plan was approved in February 2008. The Plan provides for the grant or award of stock options, restricted shares, stock-based performance units and certain other types of stock based awards, with a maximum of 2,200,000 shares available for grants or awards.

³ Shares under the Employee Stock Purchase Plan (the "Plan") are purchased in the open market by employees at the fair market value of the Company's stock. The Company provides a matching contribution of 10% of such purchases subject to certain limitations under the Plan. As the Plan is an open market purchase plan, it does not have a dilutive effect.

⁴ Shares of restricted stock may be issued under the Director Fee Plan. The maximum number of shares authorized to be issued under the Director Fee Plan is 300,000 shares.

ITEM 13. CERTAIN RELATIONSHIPS AND RELATED TRANSACTIONS.

The information required by this item as to certain relationships and transactions with management and other related parties of the Company is hereby incorporated by reference from the information appearing under the captions "Proposal No. 1 – Election of Directors" and "Certain Transactions" in the Company's definitive proxy statement, which involves the election of directors and is to be filed with the Commission pursuant to the Exchange Act, within 120 days of the end of the Company's fiscal year ended September 30, 2009.

ITEM 14. PRINCIPAL ACCOUNTING FEES AND SERVICES.

The information required by this item as to the fees billed and the services provided by the principal accounting firm of the Company is hereby incorporated by reference from the information appearing under the caption "Relationship with Independent Registered Public Accounting Firm" in the Company's definitive proxy statement, which involves the election of directors and is to be filed with the Commission pursuant to the Exchange Act within 120 days of the end of the Company's fiscal year ended September 30, 2009.

PART IV

ITEM 15. EXHIBITS, FINANCIAL STATEMENT SCHEDULES, AND REPORTS ON FORM 8-K.

(a) 1. Financial Statements:

The following items are included in Part II, Item 8:

	Pages
Management's Report to Shareholders	34
Report of Independent Registered Public Accounting Firm	35
Consolidated Balance Sheets as of September 30, 2009 and 2008	36-37
Consolidated Statements of Income for the years ended September 30, 2009, 2008 and 2007	38
Consolidated Statements of Shareholders' Equity for the years ended September 30, 2009, 2008 and 2007	39
Consolidated Statements of Cash Flows for the years ended September 30, 2009, 2008 and 2007	40
Notes to Consolidated Financial Statements	41-65
Supplementary Financial Information (unaudited)	66

2. Financial Statement Schedules:

Schedule II - Valuation and Qualifying Accounts is included on page 67 in Part II, Item 8 of this Annual Report on Form 10-K.

3. Exhibits Filed:

The index to exhibits is on pages 74-76.

(b) Reports on Form 8-K:

On July 24, 2009, Matthews filed a current report on Form 8-K under Item 2 in connection with a press release announcing its earnings for the third fiscal quarter of 2009.

SIGNATURES

Pursuant to the requirements of Section 13 or 15(d) of the Securities Exchange Act of 1934, the Registrant has duly caused this report to be signed on its behalf by the undersigned, thereunto duly authorized, on November 24, 2009.

MATTHEWS INTERNATIONAL CORPORATION

(Registrant)

By **/s/ Joseph C. Bartolacci**

Joseph C. Bartolacci
President and Chief Executive Officer

Pursuant to the requirements of the Securities Exchange Act of 1934, this report has been signed below by the following persons on behalf of the Registrant and in the capacities indicated on November 24, 2009:

/s/ Joseph C. Bartolacci

Joseph C. Bartolacci
President and Chief Executive Officer
(Principal Executive Officer)

/s/ Steven F. Nicola

Steven F. Nicola
Chief Financial Officer, Secretary
and Treasurer (Principal Financial
and Accounting Officer)

/s/ William J. Stallkamp

William J. Stallkamp, Chairman of the Board

/s/ Robert G. Neubert

Robert G. Neubert, Director

/s/ Katherine E. Dietze

Katherine E. Dietze, Director

/s/ John P. O'Leary, Jr.

John P. O'Leary, Jr., Director

/s/ Alvaro Garcia-Tunon

Alvaro Garcia-Tunon, Director

/s/ Martin Schlatter

Martin Schlatter, Director

/s/ Glenn R. Mahone

Glenn R. Mahone, Director

/s/ John D. Turner

John D. Turner, Director

MATTHEWS INTERNATIONAL CORPORATION AND SUBSIDIARIES

EXHIBITS

INDEX

The following Exhibits to this report are filed herewith or, if marked with an asterisk (*), are incorporated by reference. Exhibits marked with an "a" represent a management contract or compensatory plan, contract or arrangement required to be filed by Item 601(b)(10)(iii) of Regulation S-K.

Exhibit No.	Description	Prior Filing or Sequential Page Numbers Herein
3.1	Restated Articles of Incorporation*	Exhibit Number 3.1 to Form 10-K for the year ended September 30, 1994
3.2	Restated By-laws *	Exhibit Number 99.1 to Form 8-K dated October 18, 2007
4.1 a	Form of Revised Option Agreement of Repurchase (effective October 1, 1993)*	Exhibit Number 4.5 to Form 10-K for the year ended September 30, 1993
4.2	Form of Share Certificate for Class A Common Stock*	Exhibit Number 4.9 to Form 10-K for the year ended September 30, 1994
10.1	Revolving Credit Facility*	Exhibit Number 10.1 to Form 10-K for the year ended September 30, 2001
10.2	First Amendment to Revolving Credit Facility*	Exhibit Number 10.1 to Form 10-Q for the quarter ended March 31, 2004
10.3	Second Amendment to Revolving Credit Facility*	Exhibit Number 10.1 to Form 10-Q for the quarter ended December 31, 2004
10.4	Third Amendment to Revolving Credit Facility*	Exhibit Number 10.4 to Form 10-K for the year ended September 30, 2007
10.5 a	Supplemental Retirement Plan*	Exhibit Number 10.4 to Form 10-K for the year ended September 30, 2006
10.6 a	Officers Retirement Restoration Plan (effective April 23, 2009)	Filed Herewith
10.7 a	1992 Stock Incentive Plan (as amended through April 25, 2006)*	Exhibit Number 10.1 to Form 10-Q for the quarter ended March 31, 2006

Exhibit No.	Description	Prior Filing or Sequential Page Numbers Herein
10.8 a	Form of Stock Option Agreement*	Exhibit Number 10.7 to Form 10-K for the year ended September 30, 2008
10.9 a	Form of Restricted Stock Agreement*	Exhibit Number 10.8 to Form 10-K for the year ended September 30, 2008
10.10 a	1994 Director Fee Plan (as amended through November 13, 2008)*	Exhibit Number 10.9 to Form 10-K for the year ended September 30, 2008
10.11 a	1994 Employee Stock Purchase Plan*	Exhibit Number 10.2 to Form 10-Q for the quarter ended March 31, 1995
10.12 a	2007 Equity Incentive Plan (as amended through September 26, 2008)*	Exhibit Number 10.11 to Form 10-K for the year ended September 30, 2008
10.13	Asset Purchase Agreement by and among The York Group, Inc., Midnight Acquisition Corporation, Milso Industries, Inc., Milso Industries, LLC, SBC Holding Corporation, the Shareholders identified therein and Matthews International Corporation*	Exhibit Number 10.1 to Form 8-K dated on July 14, 2005
10.14	Sale and Purchase Agreement by and among Mr. Jorg Christian Saueressig, Mr. Karl Wilhelm Saueressig, Mr. Jakob Heinrich Saueressig, Mr. Reinhart Zech Von Hymen and Matthews International Corporation*	Exhibit Number 10.1 to Form 8-K dated May 12, 2008
10.15	Option Agreement between Mr. Kilian Saueressig and Matthews International Corporation (English translation)*	Exhibit Number 10.1 to Form 10-Q for the quarter ended June 30, 2008
14.1	Form of Code of Ethics Applicable to Executive Management*	Exhibit Number 14.1 to Form 10-K for the year ended September 30, 2004
21	Subsidiaries of the Registrant	Filed Herewith
23	Consent of Independent Registered Public Accounting Firm	Filed Herewith
31.1	Certification of Principal Executive Officer for Joseph C. Bartolacci	Filed Herewith

Exhibit No.	Description	Prior Filing or Sequential Page Numbers Herein
31.2	Certification of Principal Financial Officer for Steven F. Nicola	Filed Herewith
32.1	Certification Pursuant to 18 U.S.C. Section 1350, as Adopted Pursuant to Section 906 of the Sarbanes-Oxley Act of 2002, of Joseph C. Bartolacci	Filed Herewith
32.2	Certification Pursuant to 18 U.S.C. Section 1350, as Adopted Pursuant to Section 906 of the Sarbanes-Oxley Act of 2002, of Steven F. Nicola	Filed Herewith

Copies of any Exhibits will be furnished to shareholders upon written request. Requests should be directed to Mr. Steven F. Nicola, Chief Financial Officer, Secretary and Treasurer of the Registrant.

Matthews International Corporation and Subsidiaries ~ January 1, 2010



Matthews International Corporation

Board of Directors

seated, left to right: Joseph C. Bartolacci,

William J. Stallkamp, Katherine E. Dietze;

standing, left to right: Martin Schlatter,

Glenn R. Mahone, John P. O'Leary, Jr.,

Robert G. Neubert, John D. Turner,

Alvaro Garcia-Tunon.

Directors

William J. Stallkamp
Chairman of the Board
Retired Vice Chairman,
Mellon Financial Corporation

Joseph C. Bartolacci
President and Chief Executive Officer

Katherine E. Dietze
Retired Global Chief Operating Officer,
Investment Banking Division,
Credit Suisse First Boston

Alvaro Garcia-Tunon
Senior Vice President, Chief Financial Officer,
Wabtec Corporation

Glenn R. Mahone
Partner, Reed Smith LLP

Robert G. Neubert
Retired Partner, Ernst & Young LLP

John P. O'Leary, Jr.
Retired Senior Vice President,
SCA North America

Martin Schlatter
Senior Vice President and
Chief Marketing Officer,
Wm. Wrigley Jr. Company

John D. Turner
Retired Chairman and Chief Executive Officer,
Copperweld Corporation

Officers & Executive Management

Joseph C. Bartolacci
President and Chief Executive Officer

David F. Beck
Controller

Jennifer A. Ciccone
Vice President, Human Resources

C. Michael Dempe
Chief Operating Officer,
IDL Worldwide, Inc.

James P. Doyle
Group President, Memorialization

Brian J. Dunn
Group President, Graphics and
Marking Products

Paul C. Jensen
President, Marking Products Division

Sean F. Lydon
President, Packaging Graphics Division

Steven F. Nicola
Chief Financial Officer, Secretary
and Treasurer

Paul F. Rahill
President, Cremation Division

Franz J. Schwarz
President, Graphics Europe

Brian D. Walters
Vice President and General Counsel

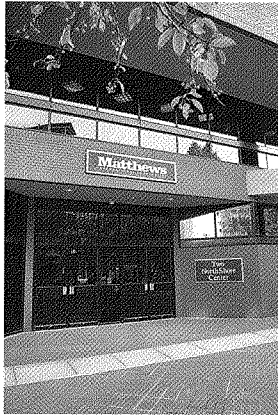

Matthews

INTERNATIONAL

Corporate Office

Two NorthShore Center
Pittsburgh, PA 15212-5851

Phone: (412) 442-8200

Fax: (412) 442-8290

Internet: www.matw.com