



09010072

Received SEC

MAR 25 2009

Washington, DC 20549

Annual Report 2008

2008

Innovative Water Solutions



A Legacy of

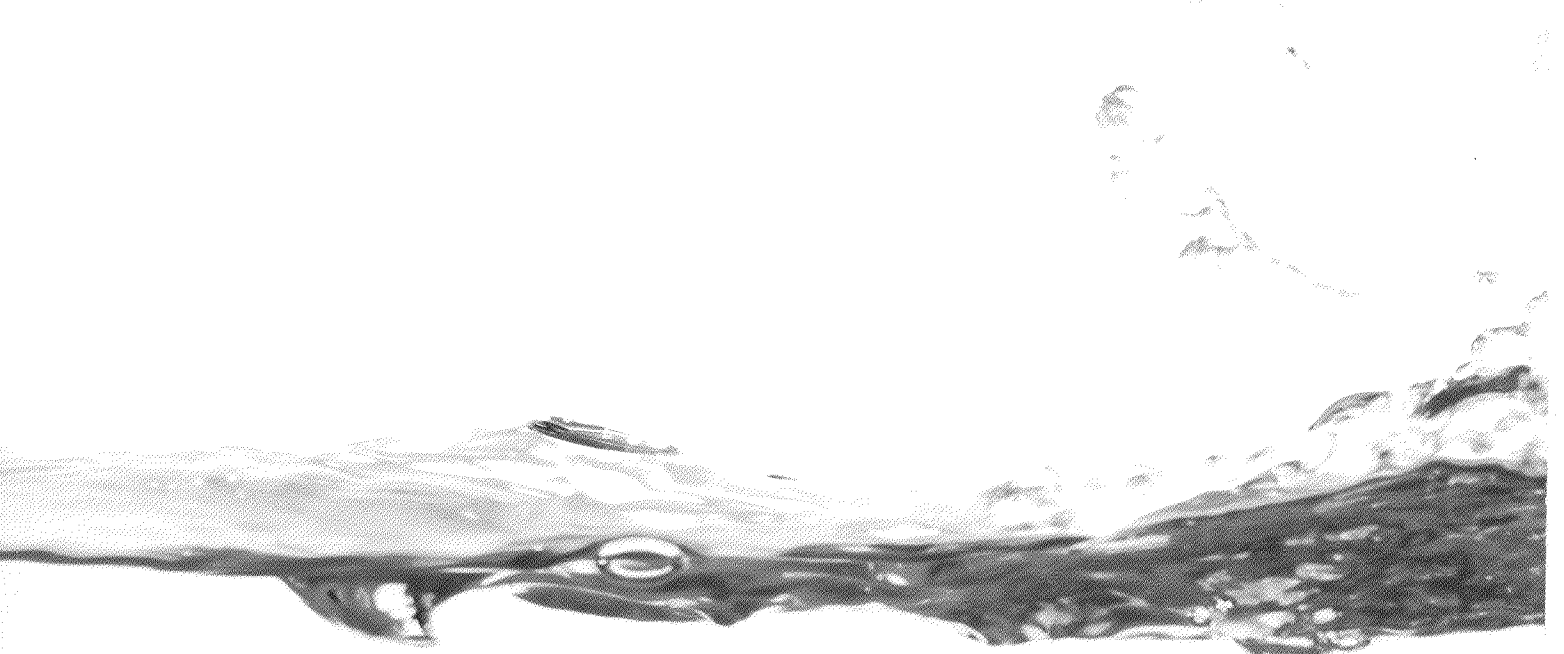
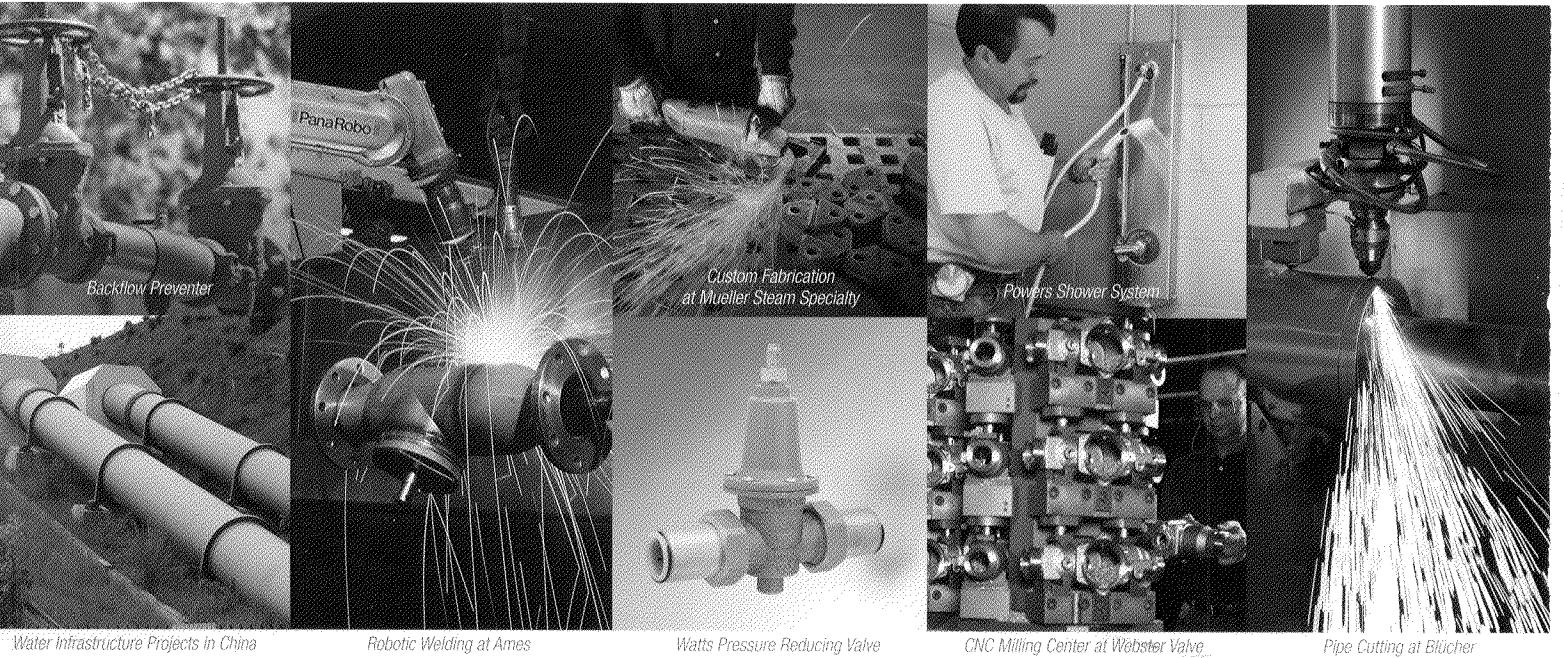

Innovation

One hundred and thirty five years ago, the then-named Watts Regulator Company developed steam pressure relief valves for

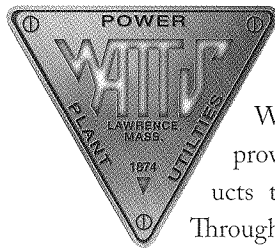

the emerging textile industry in the Merrimack Valley area of New England. Today,

Watts Water Technologies, Inc. provides a broad range of products to the global water market.

Throughout our company's history, we have developed innovative products to meet our customers' needs. Our principal product lines consist of:

- Water quality products, including back-flow preventers and check valves for preventing reverse flow within water lines and fire protection systems, point-of-use water filtration and reverse osmosis systems for both commercial and residential applications, and instrumentation reagents for water analysis.

- Water safety and flow control products, including water pressure regulators for both commercial and residential applications, water supply products for commercial and residential applications, temperature and pressure relief valves for water heaters, boilers and associated systems, and thermostatic mixing valves for tempering water in commercial and residential applications.

- Drainage and conveyance products for industrial, commercial, infrastructure, marine and residential applications.

- Water-based HVAC systems and components, including systems for under-floor radiant heating and hydraulic pump groups for gas boiler manufacturers, and renewable energy applications, including solar and heat pump control packages.

- Flexible stainless steel connectors and subassemblies for natural and liquid propane gas in commercial food service and residential applications.

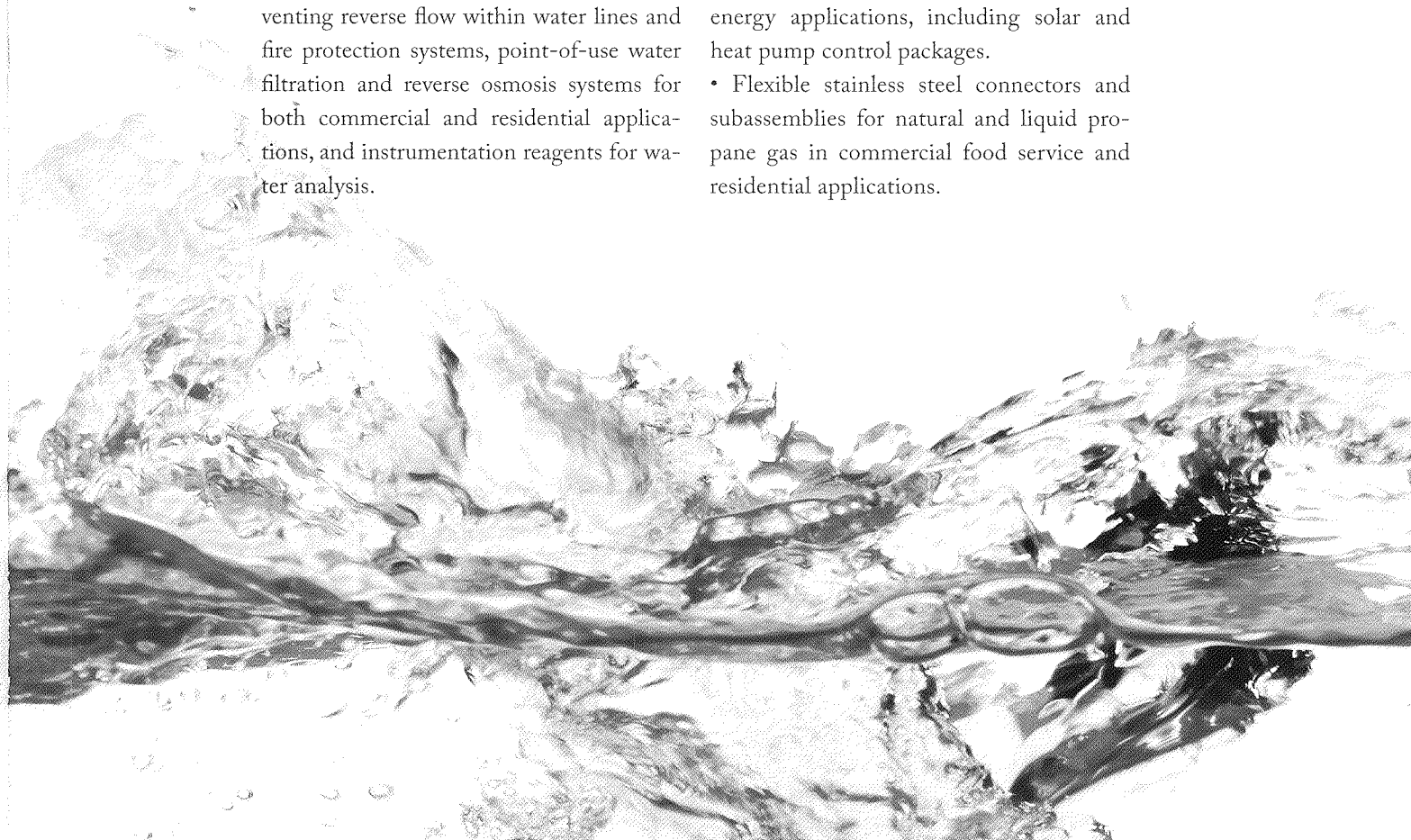
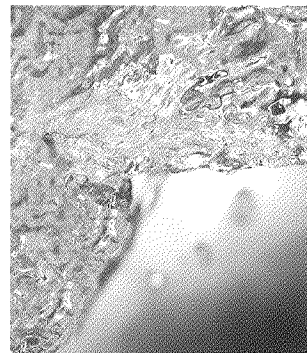



Rainwater Harvesting Systems

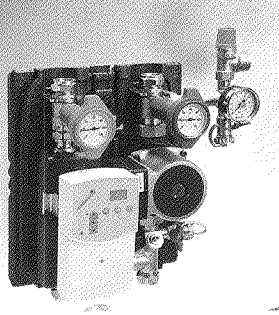

Fully Integrated Solar Control Package

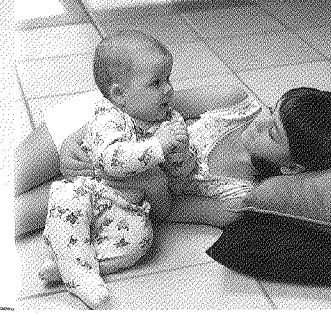

Radiant Floor Warming

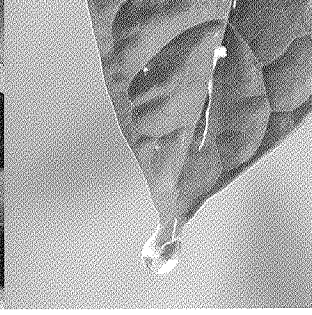

Conservation

One of the 21st century's greatest challenges is the preservation of the earth's natural resources in the face of a skyrocketing world population and the depletion of water and conventional energy sources. Consistent with our history, Watts Water Technologies strives to provide innovative products and systems that deliver clean and safe water in a controlled and resource-conscious manner.

Our membership in the United States Green Building Council demonstrates our commitment to offering an extensive product line for the sustainable building industry that reduces water and energy consumption and lowers operating costs. Our products are specified and installed in sustainable building projects and are used in renewable energy systems, such as solar and geothermal.

Our recently introduced rainwater harvesting systems preserve valuable groundwater supplies, reduce water treatment and

transport expenses, and counter rising water and wastewater costs.

In Europe, we continue to develop our line of alternative energy solutions, including our extensive line of safety and control packages for solar thermal systems, solid fuel boilers (pellets, split logs, wood chips), and geothermal heat pumps that promote both energy efficiency and environmental protection.

While Europeans have used radiant heating for decades, Watts Water Technologies has pioneered its development and widespread use in North America as a more efficient and comfortable means of heating homes and institutional and commercial buildings.

Warming floors with renewable energy and radiant energy is an ideal way to heat a space. Objects are warmed directly without overheating the air. Lower air temperatures mean less heat loss through windows and air

Safety



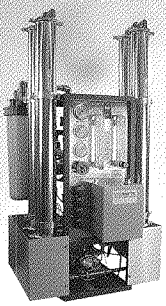

Commercial Reverse Osmosis System

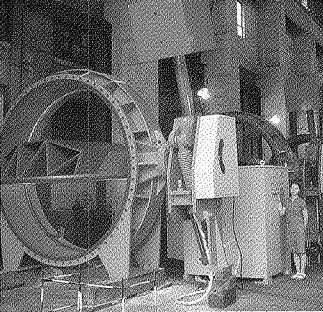

Large Diameter Butterfly Valves

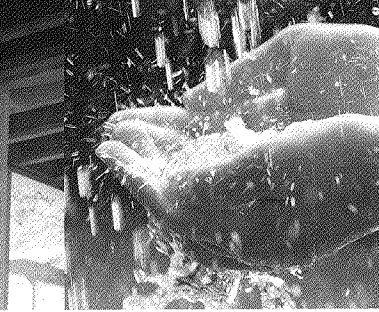

Comfort

infiltration. Zone by zone control dramatically lowers fuel consumption. In addition, our water-based radiant systems can use solar, biomass, geothermal, and waste heat recovery to heat rooms.

neers fight the battle against water scale and its destructive by-products. Our OneFlow® Anti-Scale Systems prevent scale formation by transforming dissolved hardness minerals into harmless, inactive microscopic particles. They also reduce energy consumption by keeping heat transfer surfaces free of energy-robbing scale formation and do not require chemicals or ongoing consumables (such as salt) that can harm wastewater treatment processes.

Quality

The need for pure water, both for drinking and for industrial and manufacturing uses, grows every year while the sources of clean surface water are diminishing. Our commercial grade, large volume reverse osmosis (RO) water purification systems and consumer-oriented zero waste RO systems are helping to clean and conserve water every day.

At Watts Water Technologies, our continual focus on developing products to meet our customers' needs derives from our five operational pillars – comfort, safety, quality, conservation and control. These pillars drive our product development and acquisitions and direct our search for innovative products to satisfy customers' needs in the various markets of the world we serve.

We are also providing environmentally friendly alternatives to help building owners, property managers and facility engi-

Control

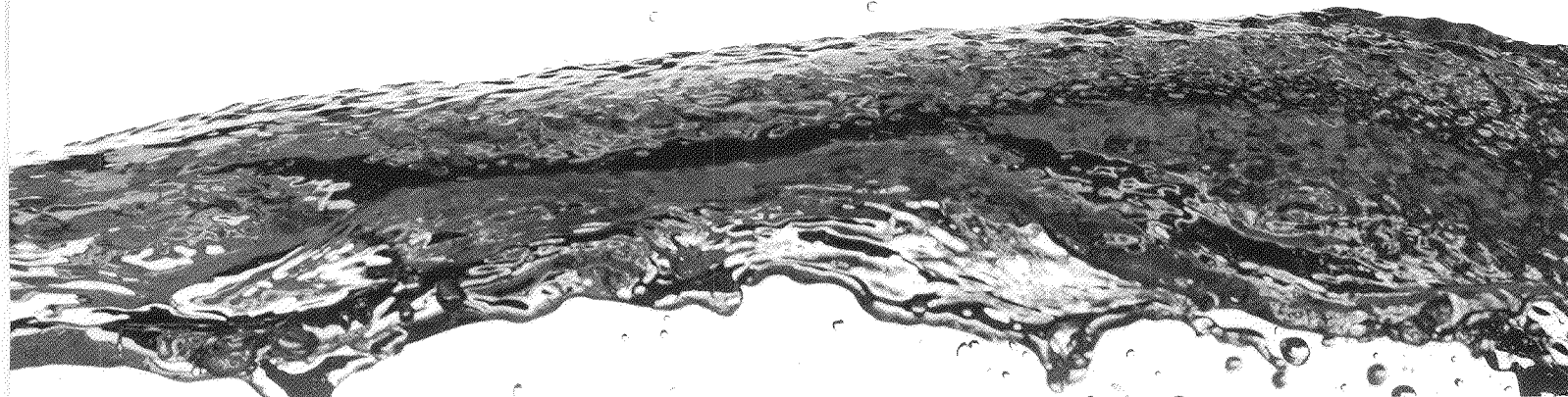

Financial Highlights

Total Net Sales

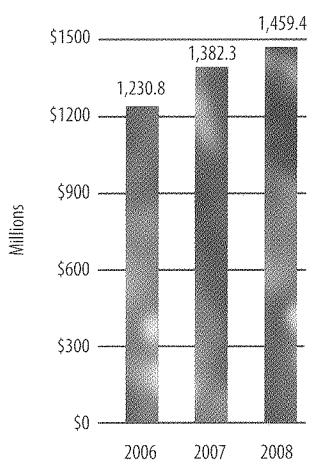

Free Cash Flow

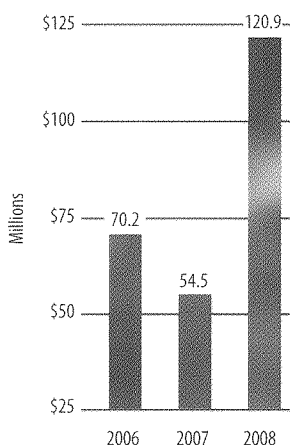

For further discussion of "free cash flow," a non-GAAP financial measure, and the comparable GAAP measure, see the section entitled "Management's Discussion and Analysis of Financial Condition and Results of Operations" in our Form 10-K included in this Annual Report to Shareholders.

North America Net Sales

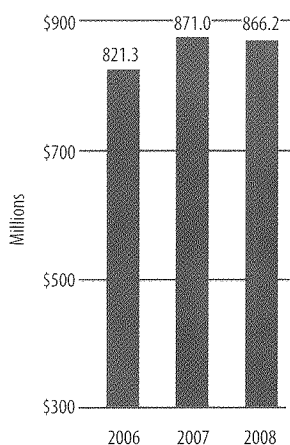

Europe Net Sales

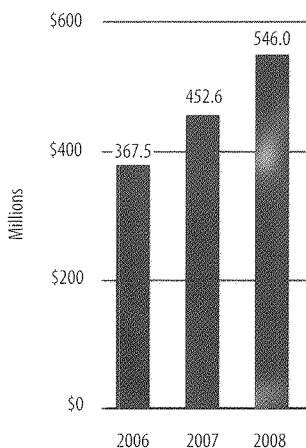

China Net Sales

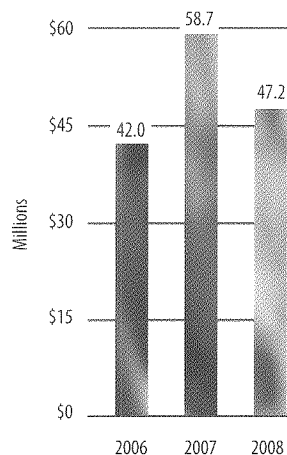

To Our Shareholders

2008 was a year in which we were able to expand and strengthen our worldwide business despite significant volatility in both our end markets and in the global financial markets.

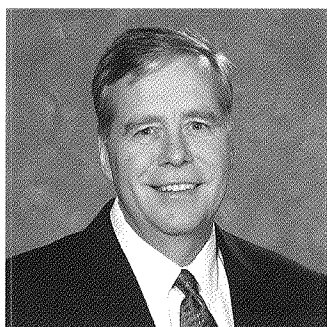

Patrick S. O'Keefe
Chief Executive Officer

The United States residential construction market declined over 30% for the second year in a row, commercial construction in the United States softened and started to decline toward year end, and European construction levels declined across most markets.

Despite this difficult environment, we were able to increase revenue due primarily to our acquisition of Blücher Metals A/S in June 2008 and increased sales of products offered to the European alternative energy markets.

Consolidated revenues grew by \$77.1 million, or 5.6%, with the net increase attributable to the following factors:

	(in millions)	% change
Organic	\$ (19.0)	(1.4)%
Acquisitions	\$ 63.7	4.6%
Foreign Exchange	\$ 35.6	2.6%
Dispositions	\$ (3.2)	(0.2)%
Total increase in net sales	\$ 77.1	5.6%

We achieved record free cash flow of \$120.9 million in 2008, an increase of \$66.4 million over 2007 and representing 259.4% of 2008 net income. This increase is the result of improved processes and focused working capital management. Although early in their implementation, we are seeing immediate benefits from lean manufacturing techniques and sales and operational planning systems. Cash generation will continue to be a focus area as we move into 2009.

2008 marked twenty-two years of continuous dividend payments to our shareholders, with a dividend of \$0.11 per share in each quarter of 2008. We also purchased 1.6 million shares of our Class A Common Stock on the open market. The dividend and our share repurchase program returned \$60.7 million of cash to our shareholders in 2008.

Our net income declined \$30.8 million, or 40.0%, to \$46.6 million in 2008 primarily attributable to the losses we incurred in our China segment and a goodwill impairment of \$17.3 million in our water quality group. Our China operations have experienced cost increases on several fronts due to the strengthening of the Chinese yuan, increases in China value added taxes, wage inflation due to new labor laws and increased costs for ocean freight when the price of oil reached record levels in mid-year.

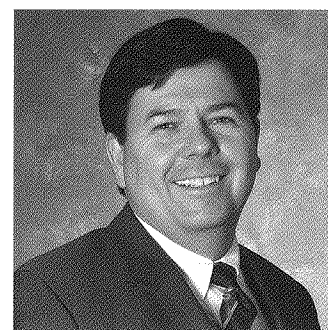

William C. McCartney
Chief Financial Officer

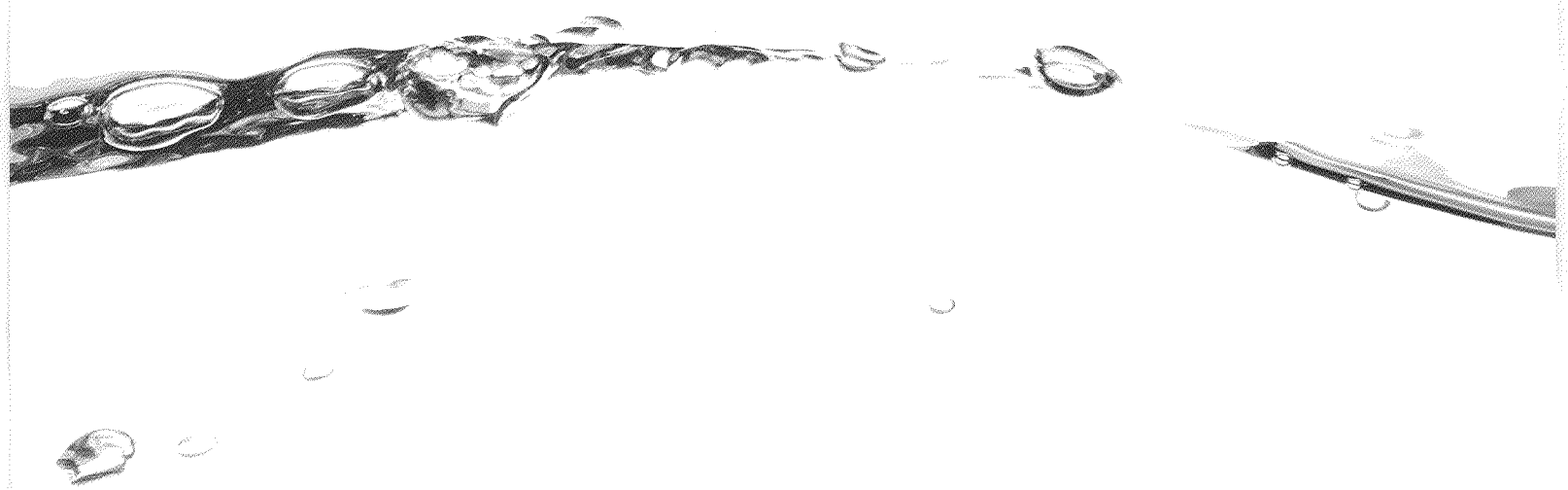

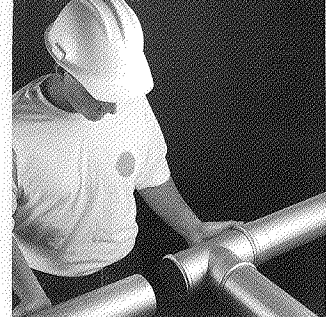

Blücher EuroPipe

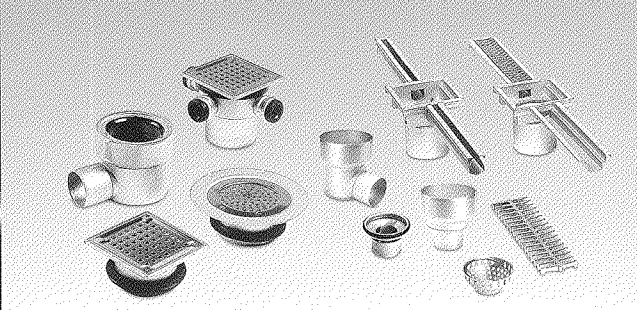

Blücher Stainless Steel Drains



Blücher Floor Drain



European Pressure Reducing Valve

In response to these rising costs, we have introduced lean manufacturing methodologies in all our China operations and we sold an underperforming manufacturing facility located in Tianjin, China. This facility, which manufactured commodity butterfly valves, accounted for 70.8% of our China segment losses through the sale date. We have also increased our focus in the fast-growing water infrastructure market in China. We are encouraged with the recent progress in our China operations as our 4th quarter results were profitable.

Consistent with our past practices, at December 31, 2008 we continued to maintain our conservative capital structure, with a net debt to capitalization ratio of 22.8%.

	December 31, 2008 <u>(in millions)</u>
Current portion of long-term debt	\$ 4.5
Plus: Long-term debt, net of current portion	409.8
Less: Cash and cash equivalents	<u>(165.6)</u>
Net debt	<u>\$ 248.7</u>
Net debt	\$ 248.7
Plus: Total stockholders' equity	842.4
Capitalization	<u>\$ 1,091.1</u>
Net Debt to Capitalization Ratio	<u>22.8%</u>

Our next scheduled debt repayment is in May 2010, when \$50 million is scheduled to be repaid. At December 31, 2008, we had \$260.0 million of unused and available capital from an existing line of credit. We believe that our capital structure, in conjunction with our cash generating capability, is a critical component for success in the current economic environment.

On June 1, 2008, we acquired Blücher Metals for approximately \$170 million, our largest acquisition to date. Blücher is a manufacturer of stainless steel drainage products based in Denmark. Blücher's 2008 revenues were almost \$90 million. Blücher provides us with a new product platform in Europe. We have a strong position in both the plumbing and heating markets in Europe, and the addition of Blücher gives us a leadership position in the stainless steel drain market. Blücher provides us with a strong brand, solid management team and many growth opportunities.

We are pleased that David Coghlan joined us this year as the President of North America

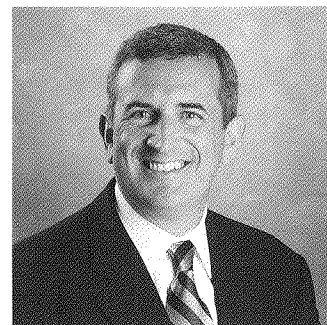

David J. Coghlan
President of North America and Asia



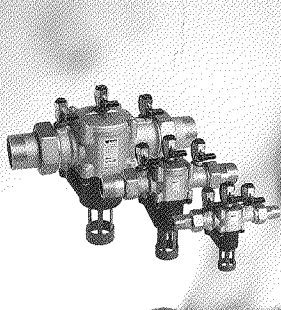

European Backflow Preventers

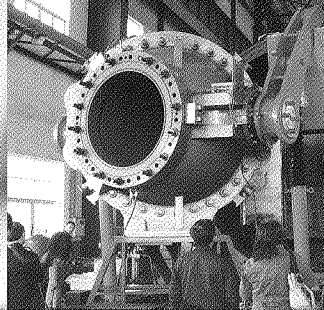

Large Diameter Ball Valve

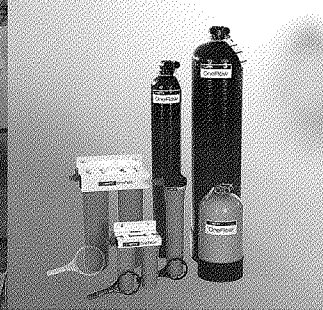

OneFlow® Anti-Scale Systems

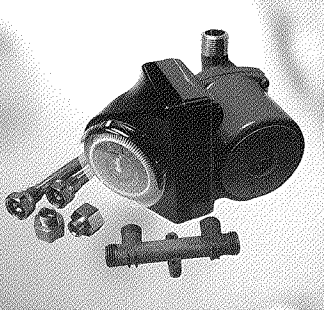

Hot Water Recirculating System

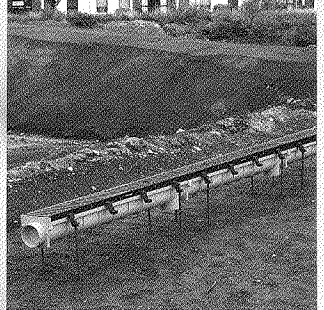

Dead Level™ Trench Drain

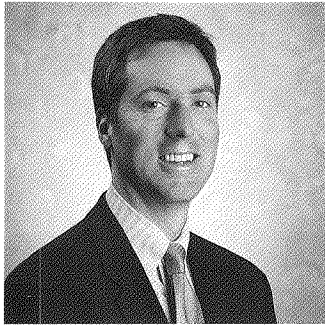

Kenneth R. Lepage
General Counsel and Secretary

and Asia. David, most recently with Trane, Inc., has spent the majority of his career in multinational manufacturing companies. Kenneth Lepage was promoted to General Counsel in August 2008. Ken joined Watts in 2003 as Assistant General Counsel. We are confident David and Ken will continue to make a meaningful contribution to Watts.

Our long history of providing innovative water solutions to our customers continued in 2008 with the introduction of many promising new products.

- In Europe, we launched a new range of backflow prevention devices and pressure reducing valves;
- In China, we introduced our first large diameter ball valve for the water infrastructure market;
- In North America, we introduced the Dead Level™ trench drain, which is more cost efficient for installers; and
- In North America, we also premiered the Watts OneFlow® anti-scale system, which prevents scale formation, thereby extending the life of pipes, plumbing fixtures and valves.

As we look ahead, we see many growth opportunities:

- We believe the demand for both energy and water conservation products will continue to increase. We currently offer a broad product line to support the use of solar and geothermal power to heat water. We also have an extensive offering of products that conserve water, including water pressure regulating valves that reduce water consumption by up to 30% while supplying a constant comfortable pressure, zero waste point-of-use reverse osmosis water filtration systems that provide better than bottle-quality water while eliminating the water waste of a typical reverse osmosis system, and our hot water recirculating system, which provides instantaneous hot water at any tap or shower.
- We expect to continue to enhance our cash flows by maintaining our focus on operational excellence. We are striving to increase our capabilities in lean manufacturing techniques, improve logistics management with widespread use of sales and operations planning, and increase our emphasis on capacity utilization through manufacturing footprint reductions.
- We intend to maintain our disciplined acquisition program to provide us access to new mar-



2008 was a year in which

we were able to

expand and strengthen
our worldwide

business despite significant
volatility in both our end markets and
in the financial markets.

kets and technologies.

- We may selectively trim our portfolio.

- We plan to leverage our worldwide IT systems to reduce costs, improve working capital management and empower our employees.

- We continue to work to provide a constant stream of innovative new products that solve our customers' water systems needs.

2009 will present us with one of our more

challenging years as we navigate through a weak worldwide economy with soft construction markets and rapidly changing foreign exchange rates and commodity costs. However, we believe that the combina-

tion of our capital structure, cash flow capability, our leading market position and the dedication of our 6,300 associates will allow us to steer a steady course through these rough waters.



Chief Executive Officer



Chief Financial Officer

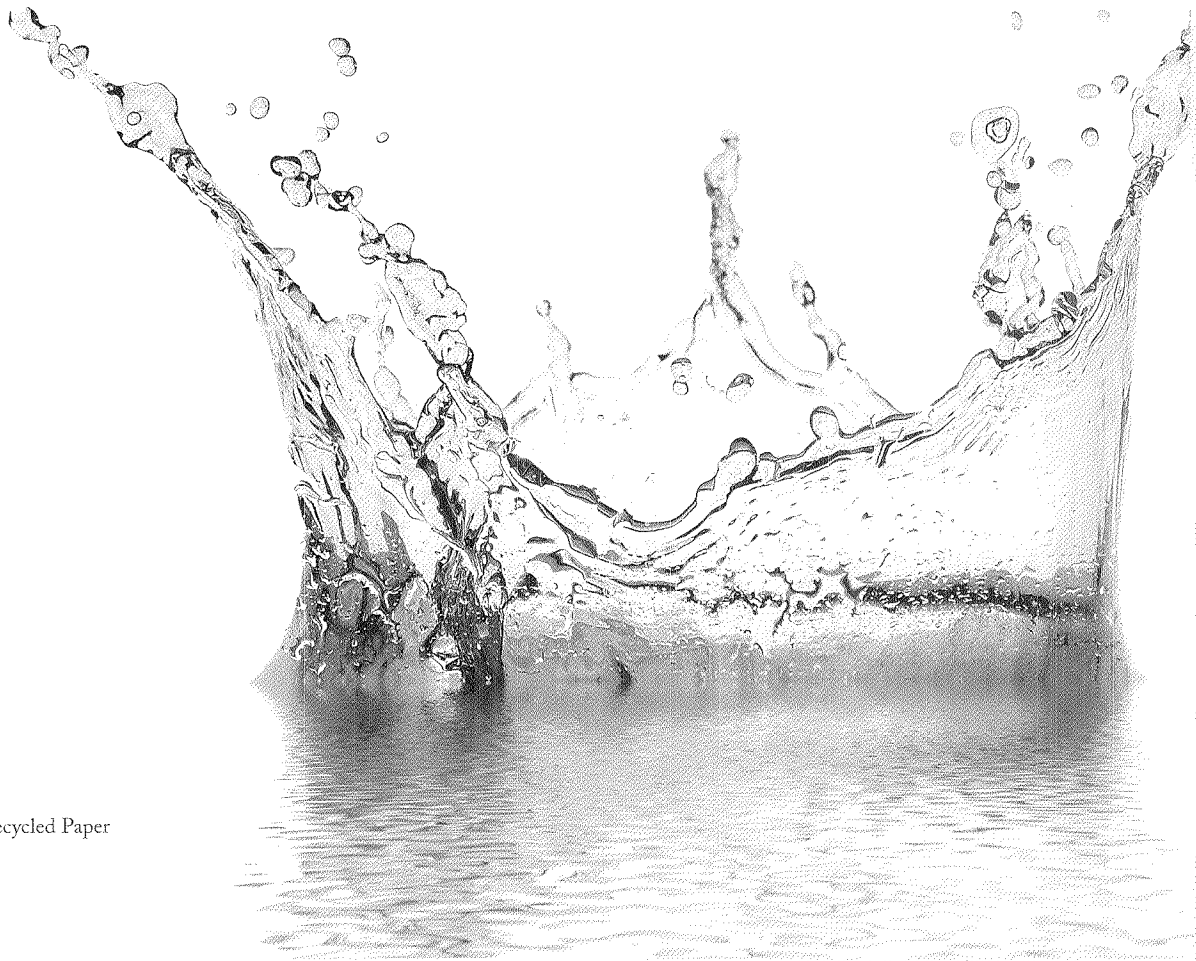

**UNITED STATES
SECURITIES AND EXCHANGE COMMISSION**

Washington, D.C. 20549

FORM 10-K

**ANNUAL REPORT PURSUANT TO SECTION 13 OR 15(d) OF THE
SECURITIES EXCHANGE ACT OF 1934**

For the fiscal year ended December 31, 2008

Or

**TRANSITION REPORT PURSUANT TO SECTION 13 OR 15(d) OF THE
SECURITIES EXCHANGE ACT OF 1934**

Commission file number 001-11499

WATTS WATER TECHNOLOGIES, INC.

(Exact name of registrant as specified in its charter)

Delaware
(State or Other Jurisdiction of
Incorporation or Organization)

815 Chestnut Street, North Andover, MA
(Address of Principal Executive Offices)

04-2916536
(I.R.S. Employer
Identification No.)

01845
(Zip Code)

Registrant's telephone number, including area code: (978) 688-1811

Securities registered pursuant to Section 12(b) of the Act:

Title of Each Class

Name of Each Exchange on Which Registered

Class A Common Stock, par value \$0.10 per share

New York Stock Exchange

Securities registered pursuant to Section 12(g) of the Act: None

Indicate by check mark if the registrant is a well-known seasoned issuer, as defined in Rule 405 of the Securities Act. Yes No

Indicate by check mark if the registrant is not required to file reports pursuant to Section 13 or Section 15(d) of the Exchange Act. Yes No

Indicate by check mark whether the registrant (1) has filed all reports required to be filed by Section 13 or 15(d) of the Securities Exchange Act of 1934 during the preceding 12 months (or for such shorter period that the registrant was required to file such reports), and (2) has been subject to such filing requirements for the past 90 days. Yes No

Indicate by check mark if disclosure of delinquent filers pursuant to Item 405 of Regulation S-K is not contained herein, and will not be contained, to the best of registrant's knowledge, in definitive proxy or information statements incorporated by reference in Part III of this Form 10-K or any amendment to this Form 10-K.

Indicate by check mark whether the registrant is a large accelerated filer, an accelerated filer, a non-accelerated filer, or a smaller reporting company. See the definitions of "large accelerated filer," "accelerated filer" and "smaller reporting company" in Rule 12b-2 of the Exchange Act. (Check one):

Large accelerated filer

Accelerated filer

Non-accelerated filer

Smaller reporting company

(Do not check if a smaller reporting company)

Indicate by check mark whether the registrant is a shell company (as defined in Rule 12b-2 of the Exchange Act). Yes No

As of June 29, 2008, the aggregate market value of the registrant's common stock held by non-affiliates of the registrant was approximately \$708,165,326 based on the closing sale price as reported on the New York Stock Exchange.

Indicate the number of shares outstanding of each of the issuer's classes of common stock, as of the latest practicable date.

Class	Outstanding at February 20, 2009
Class A Common Stock, \$0.10 par value per share	29,407,648 shares
Class B Common Stock, \$0.10 par value per share	7,193,880 shares

DOCUMENTS INCOPORATED BY REFERENCE

Portions of the Registrant's Proxy Statement for its Annual Meeting of Stockholders to be held on May 13, 2009, are incorporated by reference into Part III of this Annual Report on Form 10-K.

SEC
Mail Processing
Section
MAR 25 2009
Washington, DC
105

PART I

Item 1. BUSINESS.

This Annual Report on Form 10-K contains statements which are not historical facts and are considered forward-looking within the meaning of the Private Securities Litigation Reform Act of 1995. These forward-looking statements contain projections of our future results of operations or our financial position or state other forward-looking information. In some cases you can identify these forward-looking statements by words such as “anticipate,” “believe,” “could,” “estimate,” “expect,” “intend,” “may,” “should,” “will” and “would” or similar words. You should not rely on forward-looking statements because they involve known and unknown risks, uncertainties and other factors, some of which are beyond our control. These risks, uncertainties and other factors may cause our actual results, performance or achievements to differ materially from the anticipated future results, performance or achievements expressed or implied by the forward-looking statements. Some of the factors that might cause these differences are described under Item 1A—“Risk Factors.” You should carefully review all of these factors, and you should be aware that there may be other factors that could cause these differences. These forward-looking statements were based on information, plans and estimates at the date of this report, and, except as required by law, we undertake no obligation to update any forward-looking statements to reflect changes in underlying assumptions or factors, new information, future events or other changes.

In this Annual Report on Form 10-K, references to “the Company,” “Watts,” “we,” “us” or “our” refer to Watts Water Technologies, Inc. and its consolidated subsidiaries.

Overview

Watts Regulator Co. was founded by Joseph E. Watts in 1874 in Lawrence, Massachusetts. Watts Regulator Co. started as a small machine shop supplying parts to the New England textile mills of the 19th century and grew into a global manufacturer of products and systems focused on the control, conservation and quality of water and the comfort and safety of the people using it. Watts Water Technologies, Inc. was incorporated in Delaware in 1985 and became the parent Company of Watts Regulator Co.

Our “Water by Watts” strategy is to be the leading provider of water quality, water conservation, water safety and water flow control products for the residential and commercial markets in North America and Europe and to expand our presence in Asia. Our primary objective is to grow earnings by increasing sales within existing markets, expanding into new markets, leveraging our distribution channels and customer base, making selected acquisitions, reducing manufacturing costs and advocating for the development and enforcement of industry standards.

We intend to continue to introduce products in existing markets by enhancing our preferred brands, developing new complementary products, promoting plumbing code development to drive sales of safety and water quality products and continually improving merchandising in both the do-it-yourself (DIY) and wholesale distribution channels. We continually target selected new product and geographic markets based on growth potential, including our ability to leverage our existing distribution channels. Additionally, we continually leverage our distribution channels through the introduction of new products, as well as the integration of products of our acquired companies.

We intend to continue to generate growth by targeting selected acquisitions, both in our core markets as well as new complementary markets. We have completed 32 acquisitions since divesting our industrial and oil and gas business in 1999, including one acquisition in each of 2008 and 2007 and five acquisitions in 2006. Our acquisition strategy focuses on businesses that manufacture preferred brand name products that address our themes of water quality, water safety, water conservation, water flow control and related complementary markets. We target businesses that will provide us with one or more of the following: an entry into new markets, an increase in shelf space with existing customers, strong brand names, a new or improved technology or an expansion of the breadth of our Water by Watts offerings.

We are committed to reducing our manufacturing and operating costs through a combination of manufacturing in lower-cost countries, using Lean Six Sigma to drive continuous improvement across all key processes, and consolidating our diverse manufacturing operations in North America, Europe and China. We have acquired a number of manufacturing facilities in lower-cost regions such as China, Bulgaria and Tunisia. In 2007, we announced a global restructuring plan to reduce our manufacturing footprint in order to reduce our costs and to realize additional operating efficiencies. In February 2009, we announced an additional plan to consolidate manufacturing in North America and China. See Recent Developments in Item 7, "Management's Discussion and Analysis of Financial Condition and Results of Operations" for more details.

Our products are sold to wholesale distributors and dealers, major DIY chains and original equipment manufacturers (OEMs). Most of our sales are for products that have been approved under regulatory standards incorporated into state and municipal plumbing, heating, building and fire protection codes in North America and Europe. We have consistently advocated the development and enforcement of plumbing codes and are committed to providing products to meet these standards, particularly for safety and control valve products. These codes serve as a competitive barrier to entry by requiring that products sold in select jurisdictions meet stringent criteria.

Additionally, a majority of our manufacturing facilities are ISO 9000, 9001 or 9002 certified by the International Organization for Standardization.

Our business is reported in three geographic segments: North America, Europe and China. The contributions of each segment to net sales, operating income and the presentation of certain other financial information by segment are reported in Note 17 of the Notes to Consolidated Financial Statements and in Management's Discussion and Analysis of Financial Condition and Results of Operations included elsewhere in this report.

Recent Acquisitions and Disposition

On May 30, 2008, we purchased all of the outstanding share capital of Blücher Metal A/S (Blücher) located in Vildbjerg, Denmark, for approximately \$183.5 million, which includes the assumption of \$13.4 million of debt, net of cash acquired. Blücher is a leading provider of stainless steel drainage systems in Europe to the residential, commercial and industrial marketplaces and is a worldwide leader in providing stainless steel drainage products to the marine industry. Blücher's main products include push-fit stainless steel pipes and related fittings, light-duty drains for residential, commercial and marine applications, and drains for heavy-duty industrial applications including brewery and pharmaceutical applications.

During the second quarter of 2008, we completed the acquisition of the remaining 40% ownership of our Tianjin Tanggu Watts Valve Company Ltd. joint venture in China, known as TWT, for \$3.3 million in cash. TWT manufactured products to support the U.S. operations as well as to sell into the local China market. In the third quarter of 2008, we relocated the business supporting the U.S. from TWT into an existing operation in China. We then entered into an agreement to sell TWT. Under this agreement, we determined that the risks and rewards of ownership of TWT were effectively transferred to the buyer as of October 18, 2008. We further determined that we were no longer the primary beneficiary of the operating results of TWT and therefore had deconsolidated TWT as of the agreement date. As the equity transfer from us to the buyer has not yet been approved by local authorities, we deferred a \$1.1 million gain from the sale. We expect to recognize the gain during 2009, upon final approval of the transfer by Chinese government authorities. The deferred gain has been recorded as a current liability in the accompanying Consolidated Balance Sheet.

On November 9, 2007, we acquired the assets and business of Topway Global Inc. (Topway) located in Brea, California for approximately \$18.4 million. Topway manufactures a wide variety of water softeners, point of entry filter units, and point of use drinking water systems for residential, commercial and industrial applications.

Products

We believe that we have the broadest range of products in terms of design distinction, size and configuration in a majority of our principal product lines. In 2008 and 2007, water quality products accounted for approximately 17% and 18%, respectively, of our total sales. Our principal product lines include:

- water quality products, including backflow preventers and check valves for preventing reverse flow within water lines and fire protection systems and point-of-use water filtration and reverse osmosis systems for both commercial and residential applications;
- a wide range of water pressure regulators for both commercial and residential applications;
- drainage products for industrial, commercial, marine and residential applications;
- water supply products for commercial and residential applications;
- temperature and pressure relief valves for water heaters, boilers and associated systems;
- thermostatic mixing valves for tempering water in commercial and residential applications;
- systems for under-floor radiant applications and hydraulic pump groups for gas boiler manufacturers and renewable energy applications, including solar and heat pump control packages;
- flexible stainless steel connectors for natural and liquid propane gas in commercial food service and residential applications; and
- large diameter butterfly valves for use in China's water infrastructure.

Customers and Markets

We sell our products to plumbing, heating and mechanical wholesale distributors, major DIY chains and OEMs.

Wholesalers. Approximately 65% of our sales in both 2008 and 2007 were to wholesale distributors for both commercial and residential applications. We rely on commissioned manufacturers' representatives, some of which maintain a consigned inventory of our products, to market our product lines. Additionally, various water quality products are sold to independent dealers throughout North America.

DIY. Approximately 13% and 15% of our sales in 2008 and 2007, respectively, were to DIY customers. Our DIY customers demand less technical products, but are highly receptive to innovative designs and new product ideas.

OEMs. Approximately 22% and 20% of our sales in 2008 and 2007, respectively, were to OEMs. In North America, our typical OEM customers are water heater manufacturers, equipment manufacturers needing flow control devices and water systems manufacturers needing backflow preventers. Our sales to OEMs in Europe are primarily to boiler manufacturers, and radiant systems manufacturers. Our sales to OEMs in China are primarily to boiler and bath manufacturers including manufacturers of faucet and shower products.

In both 2008 and 2007, no customer accounted for more than 10% of our total net sales. Our top ten customers accounted for approximately \$293.9 million, or 20%, of our total net sales in 2008 and \$304.3 million, or 22%, of our total net sales in 2007. Thousands of other customers constituted the remaining 80% of our net sales in 2008 and 78% of our net sales in 2007.

Marketing and Sales

We rely primarily on commissioned manufacturers' representatives, some of which maintain a consigned inventory of our products. These representatives sell primarily to plumbing and heating wholesalers or service DIY store locations in North America. We also sell products for the residential construction and home repair and remodeling industries through DIY plumbing retailers, national catalog distribution companies, hardware stores, building material outlets and retail home center chains and through plumbing and heating wholesalers. In addition, we sell products directly to certain large OEMs and private label accounts.

Manufacturing

We have integrated and automated manufacturing capabilities, including a bronze foundry, machining, plastic extrusion and injection molding and assembly operations. Our foundry operations include metal pouring systems, automatic core making, yellow brass forging and brass and bronze die-castings. Our machining operations feature computer-controlled machine tools, high-speed chucking machines with robotics and automatic screw machines for machining bronze, brass and steel components. We have invested heavily in recent years to expand our manufacturing capabilities and to ensure the availability of the most efficient and productive equipment. We are committed to maintaining our manufacturing equipment at a level consistent with current technology in order to maintain high levels of quality and manufacturing efficiencies.

Capital expenditures and depreciation for each of the last three years were as follows:

	Years Ended December 31,		
	2008	2007	2006
	(in millions)		
Capital expenditures	\$26.6	\$37.8	\$44.7
Depreciation	\$31.8	\$28.9	\$26.7

The Company's 2006 capital expenditures included approximately \$18.0 million related to the purchase and subsequent sale-leaseback of a building in Italy.

Raw Materials

We require substantial amounts of raw materials to produce our products, including bronze, brass, cast iron, steel and plastic, and substantially all of the raw materials we require are purchased from outside sources. We had experienced increases in the costs of certain raw materials, particularly copper. Bronze and brass are copper-based alloys. Through July 3, 2008, copper prices rose significantly from demands in the worldwide marketplace. The spot price of copper, which was \$4.08 at July 3, 2008, had increased approximately 186% from December 2005. In response, we implemented price increases for some of our products that had become more expensive to manufacture due to the increases in raw material costs. During 2007 and 2006, cost increases in raw materials were not completely recovered by increased selling prices or other product cost reductions. During the latter half of 2008, commodity prices, including copper, decreased significantly as most industrialized and emerging economies began experiencing economic recessions. The spot price of copper at December 31, 2008 was \$1.32. We are not able to predict whether commodity costs, including copper, will significantly increase or decrease in the future. If commodity costs increase in the future and we are not able to reduce or eliminate the effect of the cost increases by reducing production costs or implementing price increases, our profit margins could decrease. If commodity costs continue to decline, we may experience pressures from customers to reduce our selling prices. The timing of any price reductions and decreases in commodity costs may not align. Therefore, our near-term margins in 2009 could decline.

Code Compliance

Products representing a majority of our sales are subject to regulatory standards and code enforcement which typically require that these products meet stringent performance criteria. Standards are established by such industry test and certification organizations as the American Society of Mechanical Engineers (A.S.M.E.), the Canadian Standards Association (C.S.A.), the American Society of Sanitary Engineers (A.S.S.E.), the University of Southern California Foundation for Cross-Connection Control (USC FCC), the International Association of Plumbing and Mechanical Officials (I.A.P.M.O.), Factory Mutual (F.M.), the National Sanitation Foundation (N.S.F.) and Underwriters Laboratory (U.L.). Many of these standards are incorporated into state and municipal plumbing and heating, building and fire protection codes.

National regulatory standards in Europe vary by country. The major standards and/or guidelines which our products must meet are AFNOR (France), DVGW (Germany), UNI/ICIN (Italy), KIWA (Netherlands), SVGW (Switzerland), SITAC (Sweden) and WRAS (United Kingdom). Further, there are local regulatory standards requiring compliance as well.

Together with our commissioned manufacturers' representatives, we have consistently advocated for the development and enforcement of plumbing codes. We maintain stringent quality control and testing procedures at each of our manufacturing facilities in order to manufacture products in compliance with code requirements.

We believe that product-testing capability and investment in plant and equipment is needed to manufacture products in compliance with code requirements. Additionally, a majority of our manufacturing facilities are ISO 9000, 9001 or 9002 certified by the International Organization for Standardization.

New Product Development and Engineering

We maintain our own product development staff, design teams, and testing laboratories in North America, Europe and China that work to enhance our existing products and develop new products. We maintain sophisticated product development and testing laboratories. Research and development costs included in selling, general, and administrative expense amounted to \$17.5 million, \$15.1 million and \$12.7 million for the years ended December 31, 2008, 2007 and 2006, respectively.

California and Vermont recently enacted laws that will require beginning on January 1, 2010 that all pipes, pipe and plumbing fittings and plumbing fixtures sold in those states that convey or dispense water for human consumption contain virtually no lead content. Other states, including Maryland, are currently considering similar legislation and we expect that similar laws will be adopted in other states in the future. We have invested considerable resources over the past several years to develop lead free versions of our plumbing products to comply with these new laws. We expect that our lead free product offerings will be available for sale by the fourth quarter of 2009, which should allow our customers in California and Vermont time to manage their inventories of our products to prepare for the January 1, 2010 implementation date of the new lead free standards.

Competition

The domestic and international markets for water safety and flow control devices are intensely competitive and require us to compete against some companies possessing greater financial, marketing and other resources than ours. Due to the breadth of our product offerings, the number and identities of our competitors vary by product line and market. We consider brand preference, engineering specifications, plumbing code requirements, price, technological expertise, delivery times and breadth of product offerings to be the primary competitive factors. We believe that new product development and product engineering are also important to success in the water industry and that our position in the industry is attributable in part to our ability to develop new and innovative products quickly and to adapt and enhance existing products. We continue to develop new and innovative products to enhance

market position and are continuing to implement manufacturing and design programs to reduce costs. We cannot be certain that our efforts to develop new products will be successful or that our customers will accept our new products. Although we own certain patents and trademarks that we consider to be of importance, we do not believe that our business and competitiveness as a whole are dependent on any one of our patents or trademarks or on patent or trademark protection generally.

Backlog

Backlog was approximately \$94.8 million at February 13, 2009 and was approximately \$116.8 million at February 15, 2008. We do not believe that our backlog at any point in time is indicative of future operating results.

Employees

As of December 31, 2008, our wholly-owned domestic and foreign operations employed approximately 6,300 people. None of our employees in North America or China are covered by collective bargaining agreements. In some European countries our employees are subject to traditional national collective bargaining agreements. We believe that our employee relations are good.

Available Information

We maintain a website with the address www.wattswater.com. The information contained on our website is not included as a part of, or incorporated by reference into, this Annual Report on Form 10-K. Other than an investor's own internet access charges, we make available free of charge through our website our Annual Report on Form 10-K, quarterly reports on Form 10-Q and current reports on Form 8-K, and amendments to these reports, as soon as reasonably practicable after we have electronically filed such material with, or furnished such material to, the Securities and Exchange Commission.

Certifications

Our Chief Executive Officer and Chief Financial Officer have provided the certifications required by rule 13a-14(a) under the Securities Exchange Act of 1934, copies of which are filed as exhibits to this Annual Report on Form 10-K. In addition, an annual chief executive officer certification was submitted by our Chief Executive Officer to the New York Stock Exchange on May 19, 2008 in accordance with the New York Stock Exchange listing requirements.

Executive Officers and Directors

Set forth below are the names of our executive officers and directors, their respective ages and positions with our Company and a brief summary of their business experience for at least the past five years:

<u>Name</u>	<u>Age</u>	<u>Position</u>
Patrick S. O'Keefe	56	Chief Executive Officer, President and Director
William C. McCartney	54	Chief Financial Officer and Treasurer
J. Dennis Cawte	58	Group Managing Director, Europe
David J. Coghlan	49	President of North America and Asia
Ernest E. Elliott	57	Executive Vice President of Marketing
Michael P. Flanders	50	Executive Vice President of Manufacturing Operations, North America and Asia
Josh C. Fu	52	President, Asia
Kenneth R. Lepage	38	General Counsel and Secretary
Gregory J. Michaud	47	Executive Vice President of Human Resources
Taylor K. Robinson	45	Executive Vice President of Supply Chain Management
Douglas T. White	64	Group Vice President
Robert L. Ayers(1)(3)	63	Director
Kennett F. Burnes(1)(3)	66	Director
Richard J. Carthcart(2)	64	Director
Timothy P. Horne	70	Director
Ralph E. Jackson Jr.(2)(3)	67	Director
Kenneth J. McAvoy(1)(3)	68	Director
John K. McGillicuddy(1)	65	Director
Gordon W. Moran(2)(3)	70	Non-Executive Chairman of the Board and Director
Daniel J. Murphy, III(2)(3)	67	Director

(1) Member of the Audit Committee

(2) Member of the Compensation Committee

(3) Member of the Nominating and Corporate Governance Committee

Patrick S. O'Keefe joined our Company in 2002. Prior to joining our Company, he served as President, Chief Executive Officer and Director of Industrial Distribution Group, a supplier of maintenance, repair, operating and production products, from 1999 to 2001. He was Chief Executive Officer of Zep Manufacturing, a unit of National Service Industries and a manufacturer of specialty chemicals throughout North America, Europe and Australia, from 1997 to 1999. He also held various senior management positions with Crane Co. from 1994 to 1997.

William C. McCartney joined our Company in 1985 as Controller. He was appointed our Vice President of Finance in 1994 and served as our Corporate Controller from 1988 to 1999. He was

appointed Chief Financial Officer and Treasurer in 2000. He served as Secretary of the Company from January 2000 to November 2005.

J. Dennis Cawte joined our Company in 2001 and was appointed Group Managing Director Europe. Prior to joining our Company, he was European President of PCC Valve and Controls, a division of Precision Castparts Corp., a manufacturer of components and castings to the aeronautical industry, from 1999 to 2001. He had also worked for approximately 20 years for Keystone Valve International, a manufacturer and distributor of industrial valves, where his most recent position was the Managing Director Northern Europe, Middle East, Africa and India.

David J. Coghlan joined our Company in June 2008 as President of North America and Asia. Prior to joining our Company, Mr. Coghlan served as Vice President, Global Parts of Trane Inc., a global manufacturer of commercial and residential heating, ventilation and air conditioning equipment, from April 2004 through May 2008. He also held several management positions within the Climate Control Technologies segment of Ingersoll-Rand Company Limited, a manufacturer of transport temperature control units and refrigerated display merchandisers, from 1995 to December 2003. Before joining Ingersoll-Rand, Mr. Coghlan worked for several years with the management consulting firm of McKinsey & Co. in both the United Kingdom and United States.

Ernest E. Elliott joined our Company in 1986 and has served in a variety of sales and marketing roles. He was appointed Vice President of Sales in 1991, served as Executive Vice President of Wholesale Sales and Marketing from 1996 to March 2003, Executive Vice President of Wholesale Marketing from March 2003 to February 2006 and as Executive Vice President of Marketing since February 2006. Mr. Elliott temporarily assumed responsibilities of our former Chief Operating Officer and President of North American and Asian Operations in September 2007. Prior to joining our Company, he was Vice President of BTR Inc.'s Valve Group, a diversified manufacturer of industrial and commercial valve products.

Michael P. Flanders joined our Company in October 2007 as Executive Vice President of Manufacturing Operations, North America and Asia. From August 2005 to July 2007, he served as President and Chief Operating Officer of Aavid Thermalloy, LLC, an international manufacturing company providing thermal management solutions to the computer and electronics industries. From July 2003 to April 2005, he was Vice President and General Manager of Waukesha Bearings Corporation, a manufacturer of hydrodynamic and active magnetic bearings and a subsidiary of Dover Corporation. From November 1998 to July 2003, he was General Manager of the LCN Division of Ingersoll-Rand Company Limited, which manufactured mechanical and electronic door control products.

Josh C. Fu joined our Company in January 2008 as President, Asia. From January 2007 to December 2007, he served as President and Chief Executive Officer of Reradiant International Co. Ltd., a consulting firm focused on the energy and industrial goods industries. From August 2004 to December 2006, he served as President of the China operations of Flowserve Corporation, a global manufacturer of flow control equipment, including valves, pumps, and seals. From July 2003 to August 2004, he was Executive Vice President, Product Development and Merchandise Sourcing for Intercon Merchandise Sourcing, an importer of consumer goods from China. From 2000 to 2003, he held various senior management positions with the China operations of BP p.l.c., a worldwide petroleum and petrochemicals company.

Kenneth R. Lepage was appointed General Counsel and Secretary of the Company in August 2008. Mr. Lepage originally joined our Company in September 2003 as Assistant General Counsel and Assistant Secretary. Prior to joining our Company, he was a junior partner at the law firm of Hale and Dorr LLP (now Wilmer Cutler Pickering Hale and Dorr LLP).

Gregory J. Michaud joined our Company in April 2006 as Executive Vice President of Human Resources. Prior to joining our Company, he served as Vice President, Human Resources of the

Compact Equipment division of Ingersoll-Rand Company Limited, a diversified industrial company, from June 2003 through March 2006. He served as Vice President, Human Resources of the Productivity Solutions division of Ingersoll-Rand from January 2003 to June 2003 and as Director, Human Resources & Corporate Organizational Planning of Ingersoll-Rand from June 2000 to December 2002.

Taylor K. Robinson joined our Company in September 2007 as Executive Vice President of Supply Chain Management. From January 2007 to August 2007, he owned and operated a consulting company named Global Supply Chain Solutions, which provided advice to international clients to improve their global supply chain methods and operations. From February 2004 to April 2006, he was Chief Procurement Officer for H.J. Heinz Company, an international manufacturer and marketer of processed foods. From January 1999 to January 2004, he served in various positions for Honeywell International Inc., a diversified technology and manufacturing company, including Global Supply Chain Director, Aviation Aftermarket Services, Director of Global Sourcing, Aerospace Electronic Systems and Corporate Director of Global Commodity Management—Electronics.

Douglas T. White joined our Company in 2001 as Group Vice President. Prior to joining our Company he was employed by Honeywell International, Inc., a diversified technology and manufacturing company, as Vice President of Marketing—Consumer Products Group from 1998 to 2001.

Robert L. Ayers has served as a director of our Company since October 2006. He was Senior Vice President of ITT Industries and President of ITT Industries' Fluid Technology from October 1999 until September 2005. Mr. Ayers continued to be employed by ITT Industries from September 2005 until his retirement in September 2006, during which time he focused on special projects for the company. Mr. Ayers joined ITT Industries in 1998 as President of ITT Industries' Industrial Pump Group. Before joining ITT Industries, he was President of Sulzer Industrial USA and Chief Executive Officer of Sulzer Bingham, a pump manufacturer. He is a director of T-3 Energy Services, Inc.

Kennett F. Burnes became a director of our Company in February 2009. Mr. Burnes is the retired Chairman, President and Chief Executive Officer of Cabot Corporation, a global specialty chemicals company. He was Chairman from 2001 to March 2008, President from 1995 to January 2008 and Chief Executive Officer from 2001 to January 2008. Prior to joining Cabot Corporation in 1987, Mr. Burnes was a partner at the Boston-based law firm of Choate, Hall & Stewart, where he specialized in corporate and business law for nearly 20 years. He is a director of State Street Corporation, a member of the Dana Farber Cancer Institute's Board of Trustees and a board member of the New England Conservatory. Mr. Burnes is also Chairman of the Board of Trustees of the Schepens Eye Research Institute.

Richard J. Cathcart has served as a director of our Company since October 2007. He was Vice Chairman and a member of the Board of Directors of Pentair, Inc. from February 2005 until his retirement in September 2007. Pentair is a diversified manufacturing company consisting of two operating segments: Water Technologies and Technical Products. He was appointed President and Chief Operating Officer of Pentair's Water Technologies Group in January 2001 and served in that capacity until his appointment as Vice Chairman in February 2005. He began his career at Pentair in March 1995 as Executive Vice President, Corporate Development, where he identified water as a strategic area of growth. In February 1996, he was named Executive Vice President and President of Pentair's Water Technologies Group. Prior to joining Pentair, he held several management and business development positions during his 20-year career with Honeywell International Inc. He is a director of Fluidra S.A.

Timothy P. Home has served as a director of our Company since 1962. He became an employee of our Company in 1959 and served as our President from 1976 to 1978, from 1994 to 1997 and from 1999 to 2002. He served as our Chief Executive Officer from 1978 to 2002, and he served as Chairman of our Board of Directors from 1986 to 2002. He retired as an employee of our Company on December 31, 2002. Since his retirement, he has continued to serve our Company as a consultant.

Ralph E. Jackson, Jr. has served as a director of our Company since 2004. He worked for Cooper Industries, Inc., a manufacturer of electrical products, from 1985 until his retirement in December 2003. Prior to joining Cooper Industries, he worked for the Bussmann and Air Comfort divisions of McGraw-Edison from 1976 until McGraw-Edison was acquired by Cooper Industries in 1985. While with Cooper Industries, he served as Chief Operating Officer from 2000 to December 2003, Executive Vice President, Electrical Operations from 1992 to 2000, and President, Bussmann Division from the time McGraw-Edison was acquired by Cooper Industries to 1992. He served as a member of the Board of Directors of Cooper Industries from 2000 to December 2003.

Kenneth J. McAvoy has served as a director of our Company since 1994. He was Controller of our Company from 1981 to 1985 and Chief Financial Officer and Treasurer from 1986 to 1999. He also served as Vice President of Finance from 1984 to 1994; Executive Vice President of European Operations from 1994 to 1996; and Secretary from 1985 to 1999. He retired from our Company on December 31, 1999.

John K. McGillicuddy has served as a director of our Company since 2003. He was employed by KPMG LLP, a public accounting firm, from 1965 until his retirement in 2000. He was elected into the Partnership at KPMG LLP in June 1975 where he served as Audit Partner, SEC Reviewing Partner, Partner-in-Charge of Professional Practice, Partner-in-Charge of College Recruiting and Partner-in-Charge of Staff Scheduling. He is a director of Brooks Automation, Inc. and Cabot Corporation.

Gordon W. Moran has served as a director of our Company since 1990. He has been the Chairman of Hollingsworth & Vose Company, a paper manufacturer, since 1997, and served as its President and Chief Executive Officer from 1983 to 1998.

Daniel J. Murphy, III has served as a director of our Company since 1986. He has been the Chairman of Northmark Bank, a commercial bank he founded, since 1987. Prior to forming Northmark Bank in 1987, he was a Managing Director of Knightsbridge Partners, a venture capital firm, from January to August 1987, and President and a director of Arltru Bancorporation, a bank holding company, and its wholly-owned subsidiary, Arlington Trust Company, from 1980 to 1986.

Product Liability, Environmental and Other Litigation Matters

We are subject to a variety of potential liabilities connected with our business operations, including potential liabilities and expenses associated with possible product defects or failures and compliance with environmental laws. We maintain product liability and other insurance coverage, which we believe to be generally in accordance with industry practices. Nonetheless, such insurance coverage may not be adequate to protect us fully against substantial damage claims.

Contingencies

James Jones Litigation

On June 25, 1997, Nora Armenta (the Relator) filed a civil action in the California Superior Court for Los Angeles County (the Armenta case) against James Jones Company (James Jones), Mueller Co., Tyco International (U.S.), and the Company. We formerly owned James Jones. The Relator filed under the qui tam provision of the California state False Claims Act, Cal. Govt. Code § 12650 et seq. (California False Claims Act) and generally alleged that James Jones and the other defendants violated this statute by delivering some “defective” or “non-conforming” waterworks parts to municipal water systems in the State of California. The Relator filed a First Amended Complaint in November 1998 and a Second Amended Complaint in December 2000, which brought the total number of plaintiffs to 161. The Complaint further alleges that purchased non-conforming James Jones waterworks parts may leach into public drinking water elevated amounts of lead that may create a public health risk because they were made out of ‘81 bronze alloy (UNS No. C8440) and contain more lead than the specified and advertised ‘85 bronze alloy (UNS No. C83600). This contention is based on the average difference

of about 2% lead content between '81 bronze (6% to 8% lead) and '85 bronze (4% to 6% lead) and the assumption that this would mean increased consumable lead in public drinking water that could cause a public health concern. We believe the evidence and discovery available to date indicates that this is not the case. In addition, '81 bronze is used extensively in municipal and home plumbing systems and is approved by municipal, local and national codes. The Federal Environmental Protection Agency also defines metal for pipe fittings with no more than 8% lead as "lead free" under Section 1417 of the Federal Safe Drinking Water Act.

In this case, the Relator seeks three times an unspecified amount of actual damages and alleges that the municipalities have suffered hundreds of millions of dollars in damages. She also seeks civil penalties of \$10,000 for each false claim and alleges that defendants are responsible for tens of thousands of false claims. Finally, the Relator requests an award of costs of this action, including attorneys' fees.

In December 1998, the Los Angeles Department of Water and Power (LADWP) intervened in this case and filed a complaint. We settled with the city of Los Angeles, by far the most significant city, for \$7.3 million plus attorneys' fees. Co-defendants contributed \$2.0 million toward this settlement.

In August 2003, an additional settlement payment was made for \$13.0 million (\$11.0 million from us and \$2.0 million from James Jones), which settled the claims of the three Phase I cities (Santa Monica, San Francisco and East Bay Municipal Utility District) chosen by the Relator as having the strongest claims to be tried first. In addition to this \$13.0 million payment, we are obligated to pay the Relator's attorney's fees.

On June 22, 2005, the Court dismissed the claims of the Phase II cities selected for a second trial phase (Contra Costa, Corona, Santa Cruz and Vallejo). The Court ruled that the Relator and these cities were required to show that the cities had received out of specification parts which were related to specific invoices and that this showing had not been made. Although each city's claim is unique, this ruling is significant for the claims of the remaining cities, and the Relator appealed. On June 29, 2007, the appellate court dismissed this appeal. However, this judgment can be appealed again at the conclusion of the entire case. The trial court has scheduled a trial on October 6, 2009 for six Phase III cities. Litigation is inherently uncertain, and we are unable to predict the outcome of this case.

On September 15, 2004, the Relator's attorneys filed a lawsuit in the California Superior Court for the City of Banning and 42 other cities and water districts against James Jones, Watts and Mueller Co. based on the same transactions alleged in the Armenta case alleging common law fraud. In October 2008, the Court dismissed the claims of 11 cities as time-barred. A first phase trial of selected cities is scheduled for April 13, 2010. Litigation is inherently uncertain, and we are unable to predict the outcome of this case.

On February 14, 2001, after our insurers had denied coverage for the claims in the Armenta case, we filed a complaint for coverage against our insurers in the California Superior Court (the coverage case). James Jones filed a similar complaint, the cases were consolidated, and the trial court made summary adjudication rulings that Zurich must pay all reasonable defense costs incurred by us and James Jones in the Armenta case since April 23, 1998 as well as such defense costs in the future until the end of the Armenta case. In August 2004, the California Court of Appeal affirmed these rulings, and, on December 1, 2004, the California Supreme Court denied Zurich's appeal of this decision. This denial permanently established Zurich's obligation to pay Armenta defense costs for both us and James Jones, and Zurich is currently making payments of incurred Armenta defense costs. However, as noted below, Zurich asserts that the defense costs paid by it are subject to reimbursement.

On November 22, 2002, the trial court entered a summary adjudication order that Zurich must indemnify and pay us and James Jones for amounts paid to settle with the City of Los Angeles. On August 6, 2004, the trial court made another summary adjudication ruling that Zurich must indemnify and pay us and James Jones for the \$13.0 million paid to settle the claims of the Phase I cities

described above. Zurich will be able to appeal these orders at the end of the coverage case. Zurich has now made all of the payments required by these indemnity orders.

On February 8, 2006, Zurich filed a motion to set aside as void the November 22, 2002 and August 6, 2004 summary adjudication indemnity payment orders. After this motion was denied, Zurich's appeal was also denied and the California Supreme Court denied Zurich's petition for review. We are currently unable to predict the finality of these indemnity payment orders since Zurich can also appeal them at the end of the coverage case.

Zurich has asserted that all amounts paid by it to us and James Jones are subject to reimbursement under Deductible Agreements related to the insurance policies between Zurich and Watts. We believe that the agreements are unenforceable, that the Armenta case should be viewed as one occurrence, and that the deductible amount should be \$0.5 million per occurrence if the agreements are enforceable.

On January 31, 2006, the federal district court in Chicago, Illinois determined that there are disputes under all Deductible Agreements in effect during the period in which Zurich issued primary policies and that the arbitrator could decide which agreements would control reimbursement claims. We appealed this ruling. On October 20, 2006, the United States Court of Appeals for the Seventh Circuit affirmed that an arbitration panel could decide which deductible agreements between Zurich and us would control Zurich's reimbursement claim.

Based on management's assessment, we do not believe that the ultimate outcome of the James Jones Litigation will have a material adverse effect on our liquidity, financial condition or results of operations. While this assessment is based on the facts currently known by us, litigation is inherently uncertain, the actual liability to us to resolve this litigation fully cannot be predicted with any certainty and there exists a reasonable possibility that we may ultimately incur losses in the James Jones Litigation in excess of the amount accrued. We intend to continue to contest vigorously all aspects of the James Jones Litigation.

Environmental Remediation

We have been named as a potentially responsible party with respect to a limited number of identified contaminated sites. The levels of contamination vary significantly from site to site as do the related levels of remediation efforts. Environmental liabilities are recorded based on the most probable cost, if known, or on the estimated minimum cost of remediation. We accrue estimated environmental liabilities based on assumptions, which are subject to a number of factors and uncertainties. Circumstances which can affect the reliability and precision of these estimates include identification of additional sites, environmental regulations, level of cleanup required, technologies available, number and financial condition of other contributors to remediation and the time period over which remediation may occur. We recognize changes in estimates as new remediation requirements are defined or as new information becomes available.

Based on the facts currently known to us, we do not believe that the ultimate outcome of these matters will have a material adverse effect on our liquidity, financial condition or results of operations. Some of our environmental matters are inherently uncertain and there exists a possibility that we may ultimately incur losses from these matters in excess of the amount accrued. However, we cannot currently estimate the amount of any such additional losses.

Asbestos Litigation

We are defending approximately 105 lawsuits in different jurisdictions, with the greatest number filed in Mississippi and California state courts, alleging injury or death as a result of exposure to asbestos. The complaints in these cases typically name a large number of defendants and do not identify any particular Watts products as a source of asbestos exposure. To date, we have obtained a dismissal in every case before it has reached trial because discovery has failed to yield evidence of

substantial exposure to any Watts products. Based on the facts currently known to us, we do not believe that the ultimate outcome of these claims will have a material adverse effect on our liquidity, financial condition or results of operations.

Other Litigation

Other lawsuits and proceedings or claims, arising from the ordinary course of operations, are also pending or threatened against us. Based on the facts currently known to us, we do not believe that the ultimate outcome of these other litigation matters will have a material adverse effect on our liquidity, financial condition or results of operations.

Item 1A. RISK FACTORS.

Current economic cycles, particularly reduced levels of residential and non-residential starts and remodeling, may continue to have an adverse effect on our revenues and operating results.

We have experienced and expect to continue to experience fluctuations in revenues and operating results due to economic and business cycles. The businesses of most of our customers, particularly plumbing and heating wholesalers and home improvement retailers, are cyclical. Therefore, the level of our business activity has been cyclical, fluctuating with economic cycles. The current economic downturn may also affect the financial stability of our customers, which could impact their ability to pay amounts owed vendors, including us. We also believe our level of business activity is influenced by residential and non-residential starts and renovation and remodeling, which are, in turn, heavily influenced by interest rates, consumer debt levels, changes in disposable income, employment growth and consumer confidence. The current conditions in the housing and debt markets have caused a significant reduction in residential and non-residential starts and renovation and remodeling. These conditions have caused a decrease in our revenue and profit. If these conditions continue or worsen in the future, our revenues and profits could decrease and could result in a material adverse effect on our financial condition and results of operations.

Our ability to make large acquisitions may be limited due to the current credit market conditions.

As widely reported, the financial markets worldwide have been experiencing, among other things, severely diminished liquidity and credit availability. One of our strategies is to increase our revenues and profitability and expand our markets through acquisitions. We may require capital in excess of our available cash and the unused portion of our revolving credit facility to make large acquisitions, which we would generally obtain from access to the credit markets. However, the current economic environment may adversely impact the availability and cost of credit in the future. There can be no assurance that if a large acquisition is identified that we would have access to sufficient capital to complete such acquisition.

Sales of our products to customers serving the commercial market may be impacted by the delay or cancellation of projects due to the current credit market conditions.

Our products are sold to commercial builders and others in the commercial construction market. The current credit market conditions may prevent commercial builders or developers from obtaining the necessary capital to continue existing projects or to start new projects. This may result in the delay or cancellation of orders from our customers or potential customers and may adversely affect our revenues and our ability to manage inventory levels, collect customer receivables and maintain profitability.

Our ability to improve our profitability through the introduction of new technology in the manufacturing process may be delayed due to the reallocation of capital.

With the current economic outlook worldwide, it is necessary for us to make decisions on the best immediate use of capital. In reaching those decisions, certain planned capital expenditures which would modernize or improve throughput at our manufacturing locations may be delayed until the current credit market improves. The delay of these capital expenditures may impact our ability to realize efficiencies through new technologies and may result in increased maintenance costs in the business.

We face intense competition and, if we are not able to respond to competition in our markets, our revenues may decrease.

Competitive pressures in our markets could adversely affect our competitive position, leading to a possible loss of market share or a decrease in prices, either of which could result in decreased revenues and profits. We encounter intense competition in all areas of our business. Additionally, we believe our customers are attempting to reduce the number of vendors from which they purchase in order to reduce the size and diversity of their inventories and their transaction costs. To remain competitive, we will need to invest continually in manufacturing, marketing, customer service and support and our distribution networks. We may not have sufficient resources to continue to make such investments and we may be unable to maintain our competitive position. In addition, we anticipate that we may have to reduce the prices of some of our products to stay competitive, potentially resulting in a reduction in the profit margin for, and inventory valuation of, these products. Some of our competitors are based in foreign countries and have cost structures and prices in foreign currencies. Accordingly, currency fluctuations could cause our U.S. dollar-priced products to be less competitive than our competitors' products which are priced in other currencies.

Reductions or interruptions in the supply of raw materials and changes in the costs of raw materials could reduce our profit margins and adversely affect our ability to meet our customer delivery commitments.

We require substantial amounts of raw materials, including bronze, brass, cast iron, steel and plastic and substantially all of the raw materials we require are purchased from outside sources. The availability and costs of raw materials may be subject to curtailment or change due to, among other things, new laws or regulations, suppliers' allocations to other purchasers, interruptions in production by suppliers and changes in exchange rates and worldwide price and demand levels. We typically do not enter into long-term supply agreements. Our inability to obtain adequate supplies of raw materials for our products at favorable costs, or at all, could have a material adverse effect on our business, financial condition or results of operations by decreasing our profit margins and by hindering our ability to deliver products to our customers on a timely basis. During 2006 and continuing through approximately July 3, 2008, commodity costs rose significantly from demands in the worldwide marketplace. During the latter half of 2008, commodity costs, including copper, decreased significantly as most industrialized and emerging economies began experiencing recessions. If we cannot maintain our selling prices before our inventory costs reflect the recent rapid decline in copper prices our profitability could decline. Should commodity costs increase substantially again in the future, we may not be able to completely recover such costs, as happened in 2006 and 2007, through selling price increases to our customers or other product cost reductions, which would have a negative effect on our financial results. Additionally, we continue to purchase increased levels of finished product from international sources. If there is an interruption in delivering these finished products to our domestic warehouses, this could have a negative effect on our financial results.

Implementation of our acquisition strategy may not be successful, which could affect our ability to increase our revenues or our profitability.

One of our strategies is to increase our revenues and profitability and expand our markets through acquisitions that will provide us with complementary water-related products and increase market share for our existing product lines. We cannot be certain that we will be able to identify, acquire or

profitably manage additional companies or successfully integrate such additional companies without substantial costs, delays or other problems. Also, companies acquired recently and in the future may not achieve revenues, profitability or cash flows that justify our investment in them. We expect to spend significant time and effort in expanding our existing businesses and identifying, completing and integrating acquisitions. We have faced increasing competition for acquisition candidates which have resulted in significant increases in the purchase prices of many acquisition candidates. This competition, and the resulting purchase price increases, may limit the number of acquisition opportunities available to us, possibly leading to a decrease in the rate of growth of our revenues and profitability. In addition, acquisitions may involve a number of special risks, including, but not limited to:

- inadequate internal controls over financial reporting and our ability to bring such controls into compliance with the requirements of Section 404 of the Sarbanes-Oxley Act of 2002 in a timely manner;
- adverse short-term effects on our reported operating results;
- diversion of management's attention;
- investigations of, or challenges to, acquisitions by competition authorities;
- loss of key personnel at acquired companies; and
- unanticipated management or operational problems or legal liabilities.

We are subject to risks related to product defects, which could result in product recalls and could subject us to warranty claims in excess of our warranty provisions or which are greater than anticipated due to the unenforceability of liability limitations.

We maintain strict quality controls and procedures, including the testing of raw materials and safety testing of selected finished products. However, we cannot be certain that our testing will reveal latent defects in our products or the materials from which they are made, which may not become apparent until after the products have been sold into the market. We also cannot be certain that our suppliers will always eliminate latent defects in products we purchase from them. Accordingly, there is a risk that product defects will occur, which could require a product recall. Product recalls can be expensive to implement and, if a product recall occurs during the product's warranty period, we may be required to replace the defective product. In addition, a product recall may damage our relationship with our customers and we may lose market share with our customers. Our insurance policies may not cover the costs of a product recall.

Our standard warranties contain limits on damages and exclusions of liability for consequential damages and for misuse, improper installation, alteration, accident or mishandling while in the possession of someone other than us. We may incur additional operating expenses if our warranty provision does not reflect the actual cost of resolving issues related to defects in our products. If these additional expenses are significant, it could adversely affect our business, financial condition and results of operations.

We face risks from product liability and other lawsuits, which may adversely affect our business.

We have been and expect to continue to be subject to various product liability claims or other lawsuits, including, among others, that our products include inadequate or improper instructions for use or installation, or inadequate warnings concerning the effects of the failure of our products. In the event that we do not have adequate insurance or contractual indemnification, damages from these claims would have to be paid from our assets and could have a material adverse effect on our results of operations, liquidity and financial condition. We, like other manufacturers and distributors of products designed to control and regulate fluids and gases, face an inherent risk of exposure to product liability claims and other lawsuits in the event that the use of our products results in personal injury, property damage or business interruption to our customers. Although we maintain strict quality controls and

procedures, including the testing of raw materials and safety testing of selected finished products, we cannot be certain that our products will be completely free from defect. In addition, in certain cases, we rely on third-party manufacturers for our products or components of our products. Although we have product liability and general insurance coverage, we cannot be certain that this insurance coverage will continue to be available to us at a reasonable cost, or, if available, will be adequate to cover any such liabilities. For more information, see “Item 1. Business—Product Liability, Environmental and Other Litigation Matters.”

Economic and other risks associated with international sales and operations could adversely affect our business and future operating results.

Since we sell and manufacture our products worldwide, our business is subject to risks associated with doing business internationally. Our business and future operating results could be harmed by a variety of factors, including:

- trade protection measures and import or export licensing requirements, which could increase our costs of doing business internationally;
- potentially negative consequences from changes in tax laws, which could have an adverse impact on our profits;
- difficulty in staffing and managing widespread operations, which could reduce our productivity;
- costs of compliance with differing labor regulations, especially in connection with restructuring our overseas operations;
- natural disasters and public health emergencies;
- laws of some foreign countries, which may not protect our intellectual property rights to the same extent as the laws of the United States; and
- unexpected changes in regulatory requirements, which may be costly and require time to implement.

Fluctuations in foreign exchange rates could materially affect our reported results.

We are exposed to fluctuations in foreign currencies, as a portion of our sales and certain portions of our costs, assets and liabilities are denominated in currencies other than U.S. dollars. Approximately 45.3% of our sales during the year ended December 31, 2008 were from sales outside of the U.S. compared to 41.7% for the year ended December 31, 2007. For the years ended December 31, 2008 and 2007, the appreciation of the euro against the U.S. dollar had a positive impact on sales of approximately \$31.3 million and \$34.1 million, respectively. There were also minor impacts on sales in other European currencies such as the pound sterling and Danish krone against the U.S. dollar. Additionally, our Canadian operations require significant amounts of U.S. purchases for their operations. Instead of buying or manufacturing domestically, we currently have a favorable cost structure for certain goods we source from our wholly-owned subsidiaries in China and our outside vendors. In 2005, China revalued its currency higher against the U.S. dollar and stated it would no longer tie the yuan to a fixed rate against the U.S. currency. The yuan was valued at 6.8 and 7.3 at December 31, 2008 and 2007, respectively. China also stated it will peg the yuan against numerous currencies, although it will keep the yuan in a tight band rather than letting it trade freely. The spot rate of the euro and Canadian dollar decreased in value and the yuan increased in value from December 31, 2007 to December 31, 2008 by approximately 19%, 5% and 6% respectively, against the U.S. dollar. If our share of revenue and purchases in non-dollar denominated currencies continues to increase in future periods, exchange rate fluctuations will likely have a greater impact on our results of operations and financial condition.

Our ability to achieve savings through our restructuring plans may be impacted by local regulations or factors beyond the control of management.

We implemented restructuring plans in 2007 and in 2009. Management's plans include a number of steps that we believe are necessary to reduce operating costs and increase efficiencies throughout our manufacturing footprint. Although we have considered the impact of local regulations, negotiations with employee representatives, the timing of capital expenditures necessary to prepare facilities and the related costs associated with these activities, factors beyond the control of management may impact the timing and therefore impact when the savings will be achieved under the plans. Further, if we are not successful in completing the restructuring projects in the time frames contemplated or if additional issues arise during the projects that add costs or disrupt customer service, then our operating results could be negatively affected.

If we cannot continue operating our manufacturing facilities at current or higher utilization levels, our results of operations could be adversely affected.

The equipment and management systems necessary for the operation of our manufacturing facilities may break down, perform poorly or fail, resulting in fluctuations in our ability to manufacture our products and to achieve manufacturing efficiencies. We operate a number of manufacturing facilities, all of which are subject to this risk, and such fluctuations at any of these facilities could cause an increase in our production costs and a corresponding decrease in our profitability. We also have a vertically-integrated manufacturing process. Each segment is dependent upon the prior process and any breakdown in one segment will adversely affect all later components. Fluctuations in our production process may affect our ability to deliver products to our customers on a timely basis. Our inability to meet our delivery obligations could result in a loss of our customers and negatively affect our business, financial condition and results of operations.

In addition, we have an ongoing manufacturing restructuring program to reduce our manufacturing costs. If our planned manufacturing plant consolidations in the United States, Europe and China are not successful, our results of operations and financial condition could be materially adversely affected.

If we continue to experience declines in demand, we will further reduce our production levels, resulting in lower capacity utilization that could negatively impact our results of operations.

In response to the current recessionary pressures and reduced order volumes, we have decreased our production levels to conserve cash. If we continue to experience declines in orders from customers, we will take further steps to reduce our production levels to avoid building inventory and increasing our working capital levels. While this step helps to preserve cash, a large amount of our production costs are fixed and therefore will negatively impact our ability to absorb these costs, resulting in lower gross margins for the products manufactured. Although we are expecting a certain level of decreased production volume in 2009, there can be no assurances that additional steps will not be required to reduce these levels further thereby decreasing our results from operations.

If we experience delays in introducing new products or if our existing or new products do not achieve or maintain market acceptance and regulatory approvals, our revenues and our profitability may decrease.

Our failure to develop new and innovative products or to custom design existing products could result in the loss of existing customers to competitors or the inability to attract new business, either of which may adversely affect our revenues. Our industry is characterized by:

- intense competition;
- changes in specifications required by our customers, plumbing codes and/or regulatory agencies;
- changes in requirements under new legislation;

- technically complex products; and
- constant improvement to existing products and introductions of new products.

We believe our future success will depend, in part, on our ability to anticipate or adapt to these factors and to offer, on a timely basis, products that meet customer demands and the requirements of plumbing codes and/or regulatory agencies. The development of new or enhanced products is a complex and uncertain process requiring the anticipation of technological and market trends. We may experience design, manufacturing, marketing or other difficulties, such as an inability to attract a sufficient number of experienced engineers, that could delay or prevent our development, introduction, approval or marketing of new products or enhancements and result in unexpected expenses. Such difficulties could cause us to lose business from our customers and could adversely affect our competitive position; in addition, added expenses could decrease the profitability associated with those products that do not gain market acceptance. Additionally, we recently developed lead free versions of many of our plumbing products to comply with new lead content standards going into effect in California and Vermont. If our lead free products fail to comply with these new standards or if we encounter difficulties in the manufacturing processes for these products, we could lose a substantial amount of business from customers in California and Vermont and any other states that adopt similar standards in the future.

Environmental compliance costs and liabilities could increase our expenses or reduce our profitability.

Our operations and properties are subject to extensive and increasingly stringent laws and regulations relating to environmental protection, including laws and regulations governing air emissions, water discharges, waste management and disposal and workplace safety. Such laws and regulations can impose substantial fines and sanctions for violations and require the installation of costly pollution control equipment or operational changes to limit pollution emissions and/or decrease the likelihood of accidental hazardous substance releases. We could be required to halt one or more portions of our operations until a violation is cured. We could also be liable for the costs of property damage or personal injury to others. Although we attempt to operate in compliance with these environmental laws, we may not succeed in this effort at all times. The costs of curing violations or resolving enforcement actions that might be initiated by government authorities could be substantial.

Under certain environmental laws, the current and past owners or operators of real property may be liable for the costs of cleaning up contamination, even if they did not know of or were not responsible for such contamination. These laws also impose liability on any person who arranges for the disposal or treatment of hazardous waste at any site. We have been named as a potentially responsible party or are otherwise conducting remedial activities with respect to a limited number of identified contaminated sites, including sites we currently own or operate. There can be no assurances that our ownership and operation of real property and our disposal of waste will not lead to other liabilities under these laws.

We have incurred, and expect to continue to incur, costs relating to environmental matters. In addition, new laws and regulations, stricter enforcement of existing laws and regulations, the discovery of previously unknown contamination or the imposition of new clean-up requirements could require us to incur additional costs or become the basis for new or increased liabilities that could be significant. Environmental litigation, enforcement and compliance are inherently uncertain and we may experience significant costs in connection with environmental matters. For more information, see “Item 1. Business—Product Liability, Environmental and Other Litigation Matters.”

Third parties may infringe our intellectual property and we may expend resources enforcing our rights or suffer competitive injury.

We rely on a combination of patents, copyrights, trademarks, trade secrets, confidentiality provisions and licensing arrangements to establish and protect our proprietary rights. We may be required to spend resources to monitor and police our intellectual property rights. If we fail to

successfully enforce our intellectual property rights, our competitive position could suffer, which could harm our operating results. We have been limited from selling products from time-to-time because of existing patents.

The requirements of Financial Accounting Standards Board Statement No. 142, "Goodwill and Other Intangible Assets" (FAS 142) may result in a write-off of all or a portion of our goodwill and non-amortizable intangible assets, which would negatively affect our operating results and financial condition.

As of December 31, 2008, we recorded goodwill and non-amortizable intangible assets of \$431.3 million and \$62.0 million, respectively. In lieu of amortization, we are required to perform an annual impairment review of both goodwill and non-amortizable intangible assets. In 2008, in performing our annual goodwill review, we recognized a non-cash pre-tax charge of approximately \$22.0 million as an impairment of all the goodwill value related to one reporting unit. Although we did not experience goodwill impairment in our remaining reporting units, there can be no assurances that future goodwill impairment will not occur. We perform our annual test for indications of goodwill and non-amortizable intangible assets impairment in the fourth quarter of our fiscal year or sooner if indicators of impairment exist.

The loss or financial instability of a major customer could have an adverse effect on our results of operations.

In 2008, our top ten customers accounted for approximately 20% of our total net sales with no one customer accounting for more than approximately 5% of our total net sales. Our customers generally are not obligated to purchase any minimum volume of products from us and are able to terminate their relationships with us at any time. In addition, increases in the prices of our products could result in a reduction in orders for our customers. A significant reduction in orders from, or change in terms of contracts with, any significant customers could have a material adverse effect on our future results of operations. Furthermore, some of our major customers are facing financial challenges due to market declines and heavy debt levels; should these challenges become acute, our results could be materially adversely affected due to reduced orders and/or payment delays or defaults.

Certain indebtedness may limit our ability to pay dividends, incur additional debt and make acquisitions and other investments.

Our revolving credit facility and other senior indebtedness contain operational and financial covenants that restrict our ability to make distributions to stockholders, incur additional debt and make acquisitions and other investments unless we satisfy certain financial tests and comply with various financial ratios. If we do not maintain compliance with these covenants, our creditors could declare a default under our revolving credit facility or senior notes and our indebtedness could be declared immediately due and payable. Our ability to comply with the provisions of our indebtedness may be affected by changes in economic or business conditions beyond our control. Further, given the current condition of the credit markets, should we require additional debt financing above our existing credit limit, we cannot be assured such financing would be available to us or available to us on reasonable economic terms.

Investments in auction rate securities and rights issued by UBS are subject to risks which may cause losses and affect the liquidity of these investments.

At December 31, 2008, we held \$6.0 million in auction rate securities (ARS) at fair value whose underlying investments are AA rated municipal bonds and student loans and \$2.3 million in rights issued by UBS, AG (UBS). All of our ARS were sold by UBS. In the fourth quarter of 2008, UBS issued a settlement offer to the holder of certain ARS including all of the securities held by us. Under the terms of the settlement offer, UBS issued non-transferable rights entitling the holder to sell the underlying ARS at par to UBS at any time during the period June 30, 2010 through July 2, 2012, after which time the rights expire. UBS could elect at any time from the settlement through the expiration of the settlement agreement to purchase the ARS, in which case UBS would be required to pay par value

for the ARS. The value of the ARS and the related rights from UBS are subject to the credit risk of the underlying agencies which originally issued the bonds as well as the credit risk of UBS. If UBS is unable to perform under the terms of the rights agreements, we could incur losses to liquidate the remaining securities or hold the securities to maturity.

One of our stockholders can exercise substantial influence over our Company.

As of February 1, 2009, Timothy P. Horne, a member of our board of directors, beneficially owned approximately 19.8% of our outstanding shares of Class A Common Stock (assuming conversion of all shares of Class B Common Stock beneficially owned by Mr. Horne into Class A Common Stock) and approximately 99.0% of our outstanding shares of Class B Common Stock, which represents approximately 70.7% of the total outstanding voting power. As long as Mr. Horne controls shares representing at least a majority of the total voting power of our outstanding stock, Mr. Horne will be able to unilaterally determine the outcome of most stockholder votes, and other stockholders will not be able to affect the outcome of any such votes.

Conversion and sale of a significant number of shares of our Class B Common Stock could adversely affect the market price of our Class A Common Stock.

As of February 1, 2009, there were outstanding 29,251,739 shares of our Class A Common Stock and 7,293,880 shares of our Class B Common Stock. Shares of our Class B Common Stock may be converted into Class A Common Stock at any time on a one for one basis. Under the terms of a registration rights agreement with respect to outstanding shares of our Class B Common Stock, the holders of our Class B Common Stock have rights with respect to the registration of the underlying Class A Common Stock. Under these registration rights, the holders of Class B Common Stock may require, on up to two occasions, that we register their shares for public resale. If we are eligible to use Form S-3 or a similar short-form registration statement, the holders of Class B Common Stock may require that we register their shares for public resale up to two times per year. If we elect to register any shares of Class A Common Stock for any public offering, the holders of Class B Common Stock are entitled to include shares of Class A Common Stock into which such shares of Class B Common Stock may be converted in such registration. However, we may reduce the number of shares proposed to be registered in view of market conditions. We will pay all expenses in connection with any registration, other than underwriting discounts and commissions. If all of the available registered shares are sold into the public market the trading price of our Class A Common Stock could decline.

Our Class A Common Stock has insignificant voting power.

Our Class B Common Stock entitles its holders to ten votes for each share and our Class A Common Stock entitles its holders to one vote per share. As of February 1, 2009, our Class B Common Stock constituted 20.0% of our total outstanding common stock and 71.4% of the total outstanding voting power and thus is able to exercise a controlling influence over our business.

Item 1B. UNRESOLVED STAFF COMMENTS.

None.

Item 2. PROPERTIES.

As of December 31, 2008, we maintained approximately 74 facilities worldwide, including our corporate headquarters located in North Andover, Massachusetts. The remaining facilities consist of foundries, manufacturing facilities, warehouses, sales offices and distribution centers. The principal properties in each of our three geographic segments and their location, principal use and ownership status are set forth below:

North America:

<u>Location</u>	<u>Principal Use</u>	<u>Owned/Leased</u>
North Andover, MA	Corporate Headquarters	Owned
Export, PA	Manufacturing	Owned
Franklin, NH	Manufacturing/Distribution	Owned
Burlington, ON, Canada	Manufacturing/Distribution	Owned
Kansas City, KS	Manufacturing	Owned
Fort Myers, FL	Manufacturing	Owned
St. Pauls, NC	Manufacturing	Owned
Spindale, NC	Manufacturing/Distribution	Owned
Chesnee, SC	Manufacturing	Owned
Dunnellon, FL	Warehouse	Owned
San Antonio, TX	Warehouse	Owned
Springfield, MO	Manufacturing/Distribution	Leased
Langley, BC, Canada	Manufacturing	Leased
Houston, TX	Manufacturing	Leased
Brea, CA	Manufacturing	Leased
Phoenix, AZ	Warehouse	Leased
Kansas City, KS	Distribution Center	Leased
Reno, NV	Distribution Center	Leased
Vernon, CA	Distribution Center	Leased
Calgary, AB, Canada	Distribution Center	Leased

Europe:

<u>Location</u>	<u>Principal Use</u>	<u>Owned/Leased</u>
Eerbeek, Netherlands	European Headquarters/ Manufacturing	Owned
Biassono, Italy	Manufacturing	Owned
Brescia, Italy	Manufacturing	Owned
Landau, Germany	Manufacturing	Owned
Fresseneville, France	Manufacturing	Owned
Hautvillers, France	Manufacturing	Owned
Plovdiv, Bulgaria	Manufacturing	Owned
Ammanford, United Kingdom	Manufacturing	Owned
Vildjberg, Denmark	Manufacturing	Owned
Rosières, France	Manufacturing	Leased
Monastir, Tunisia	Manufacturing	Leased
Gardolo, Italy	Manufacturing	Leased
Sorgues, France	Manufacturing	Leased
Grenoble, France	Manufacturing	Leased
Vojens, Denmark	Warehouse	Leased

China:

<u>Location</u>	<u>Principal Use</u>	<u>Owned/Leased</u>
Shanghai, China	Asian Headquarters	Leased
Tianjin Tanggu District, THMT, China	Manufacturing	Owned
Taizhou, Yuhuan, China	Manufacturing	Owned
Hunan, Changsha, China	Manufacturing	Owned
Ningbo, Beilun, China	Manufacturing	Owned
Ningbo, Beilun Port, China	Distribution Center	Leased

Certain of our facilities are subject to mortgages and collateral assignments under loan agreements with long-term lenders. In general, we believe that our properties, including machinery, tools and equipment, are in good condition, well maintained and adequate and suitable for their intended uses. Many of our manufacturing plants, especially in North America and China, are currently operating at levels that our management considers below normal capacity due to the current worldwide recession. As part of its continuous manufacturing footprint review, in 2009, management will execute a plan to further consolidate its North America and Chinese operations. See Recent Developments in Item 7, “Management’s Discussion and Analysis of Financial Condition and Results of Operations,” for more details.

Item 3. LEGAL PROCEEDINGS.

We are from time to time involved in various legal and administrative procedures. See Item 1, “Business—Product Liability, Environmental and Other Litigation Matters,” which is incorporated herein by reference.

Item 4. SUBMISSION OF MATTERS TO A VOTE OF SECURITY HOLDERS.

There were no matters submitted during the fourth quarter of the fiscal year covered by this Annual Report to a vote of security holders through solicitation of proxies or otherwise.

PART II

Item 5. MARKET FOR REGISTRANT'S COMMON EQUITY, RELATED STOCKHOLDER MATTERS AND ISSUER PURCHASES OF EQUITY SECURITIES.

The following table sets forth the high and low sales prices of our Class A Common Stock on the New York Stock Exchange during 2008 and 2007 and cash dividends paid per share.

	2008			2007		
	High	Low	Dividend	High	Low	Dividend
First Quarter	\$30.75	\$24.02	\$0.11	\$46.71	\$35.05	\$0.10
Second Quarter	31.00	24.17	0.11	41.34	36.10	0.10
Third Quarter	33.00	21.89	0.11	39.96	30.40	0.10
Fourth Quarter	29.90	16.67	0.11	33.09	25.40	0.10

There is no established public trading market for our Class B Common Stock, which is held exclusively by members of the Horne family. The principal holders of such stock are subject to restrictions on transfer with respect to their shares. Each share of our Class B Common Stock (10 votes per share) is convertible into one share of Class A Common Stock (1 vote per share).

Aggregate common stock dividend payments for 2008 and 2007 were \$16.2 million and \$15.6 million, respectively. While we presently intend to continue to pay cash dividends, the payment of future cash dividends depends upon the Board of Directors' assessment of our earnings, financial condition, capital requirements and other factors.

The number of record holders of our Class A Common Stock as of February 22, 2009 was 166. The number of record holders of our Class B Common Stock as of February 22, 2009 was 7.

We satisfy the minimum withholding tax obligation due upon the vesting of shares of restricted stock and the conversion of restricted stock units into shares of Class A Common Stock by automatically withholding from the shares being issued a number of shares with an aggregate fair market value on the date of such vesting or conversion that would satisfy the withholding amount due.

We did not withhold any Class A Common Stock for withholding tax obligations during the quarter ended December 31, 2008.

The following table includes information with respect to repurchases we made of our Class A Common Stock during the quarter ended December 31, 2008.

Period	Issuer Purchases of Equity Securities			
	(a) Total Number of Shares (or Units) Purchased	(b) Average Price Paid per Share (or Unit)	(c) Total Number of Shares (or Units) Purchased as Part of Publicly Announced Plans or Programs(1)	(d) Maximum Number (or Approximate Dollar Value) of Shares (or Units) that May Yet Be Purchased Under the Plans or Programs(1)
September 29, 2008 - October 26, 2008	—	—	—	553,615
October 27, 2008 - November 23, 2008	—	—	—	553,615
November 24, 2008 - December 31, 2008	—	—	—	553,615
Total	—	—	—	553,615

(1) On November 9, 2007, we announced that our Board of Directors had authorized a stock repurchase program. Under the program, we may repurchase up to an aggregate of 3.0 million shares of our Class A Common Stock in open market purchases or in privately negotiated transactions. On October 28, 2008, the Company announced that it had temporarily suspended its stock repurchase program. No shares were repurchased during the quarter ended December 31, 2008. As of December 31, 2008, we had repurchased 2.45 million shares of stock for a total cost of \$68.1 million.

Performance Graph

Set forth below is a line graph comparing the cumulative total shareholder return on our Class A Common Stock for the last five years with the cumulative return of companies on the Standard & Poor's 500 Stock Index and the Russell 2000 Index. We chose the Russell 2000 Index because it represents companies with a market capitalization similar to that of Watts. The graph assumes that the value of the investment in our Class A Common Stock and each index was \$100 at December 31, 2003 and that all dividends were reinvested.

COMPARISON OF 5 YEAR CUMULATIVE TOTAL RETURN* Among Watts Water Technologies, Inc., The S&P 500 Index and The Russell 2000 Index

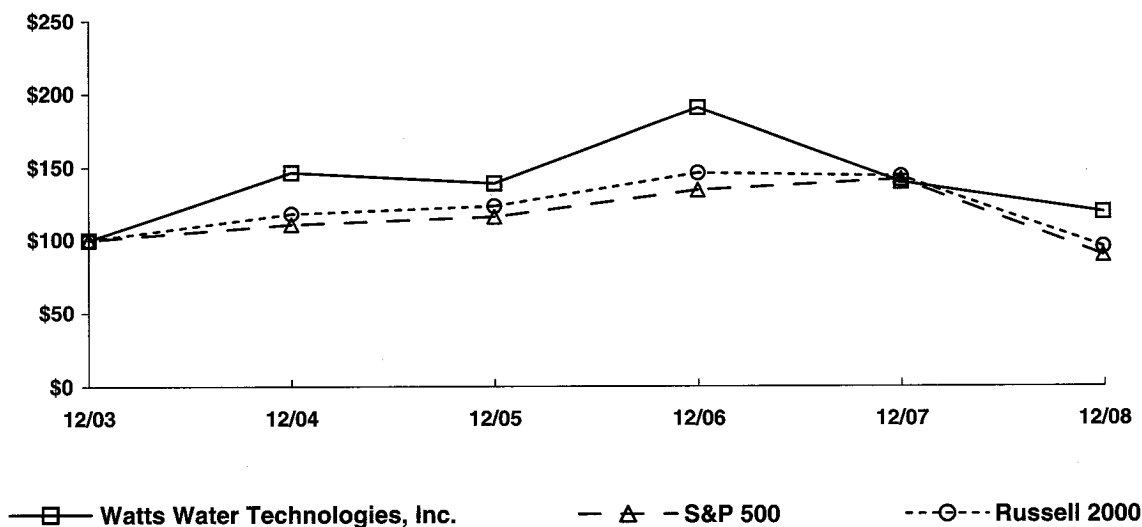

* \$100 invested on December 31, 2003 in stock or index, including reinvestment of dividends. Fiscal year ending December 31.

Cumulative Total Return

	<u>12/31/03</u>	<u>12/31/04</u>	<u>12/31/05</u>	<u>12/31/06</u>	<u>12/31/07</u>	<u>12/31/08</u>
Watts Water Technologies, Inc.	100.00	146.82	139.36	191.03	140.11	119.52
S&P 500	100.00	110.88	116.33	134.70	142.10	89.53
Russell 2000	100.00	118.33	123.72	146.44	144.15	95.44

The above Performance Graph and related information shall not be deemed "soliciting material" or to be "filed" with the Securities and Exchange Commission, nor shall such information be incorporated by reference into any future filing under the Securities Act of 1933 or Securities Exchange Act of 1934, each as amended, except to the extent that we specifically incorporate it by reference into such filing.

Item 6. SELECTED FINANCIAL DATA.

The selected financial data set forth below should be read in conjunction with our consolidated financial statements, related Notes thereto and “Management’s Discussion and Analysis of Financial Condition and Results of Operations” included herein.

FIVE-YEAR FINANCIAL SUMMARY

(Amounts in millions, except per share and cash dividend information)

	<u>Year Ended</u> <u>12/31/08(1)(8)</u>	<u>Year Ended</u> <u>12/31/07(2)(8)</u>	<u>Year Ended</u> <u>12/31/06(3)(8)</u>	<u>Year Ended</u> <u>12/31/05(4)(5)(8)</u>	<u>Year Ended</u> <u>12/31/04(6)(7)(8)</u>
Statement of operations data:					
Net sales	\$1,459.4	\$1,382.3	\$1,230.8	\$ 924.3	\$824.6
Income from continuing operations	47.3	77.6	77.1	55.0	48.7
Loss from discontinued operations, net of taxes	(0.7)	(0.2)	(3.4)	(0.4)	(1.9)
Net income	46.6	77.4	73.7	54.6	46.8
Income per share from continuing operations—diluted	1.28	1.99	2.29	1.67	1.49
Loss per share from discontinued operations—diluted	(0.02)	(0.01)	(0.10)	(0.01)	(0.06)
Net income per share—diluted	1.26	1.99	2.19	1.66	1.43
Cash dividends declared per common share	\$ 0.44	\$ 0.40	\$ 0.36	\$ 0.32	\$ 0.28
Balance sheet data (at year end):					
Total assets	\$1,660.1	\$1,729.3	\$1,660.9	\$1,101.0	\$922.7
Long-term debt, net of current portion	\$ 409.8	\$ 432.2	\$ 441.7	\$ 293.4	\$180.6

- (1) For the year ended December 31, 2008, net income includes the following net pre-tax costs: goodwill impairment, severance costs, asset write-downs and other costs in North America of \$22.0 million, \$2.6 million, \$0.4 million and \$1.5 million respectively; accelerated depreciation and other costs in China of \$1.0 million and \$0.2 million, respectively and minority interest income of \$0.2 million; severance costs in Europe of \$0.2 million. The after-tax cost of these items was \$21.2 million.
- (2) For the year ended December 31, 2007, net income includes the following net pre-tax costs: change in estimate of workers’ compensation costs of \$2.9 million, severance and product line discontinuance costs in North America of \$0.4 million and \$3.1 million, respectively; accelerated depreciation and asset write-downs, product line discontinuance costs and severance costs in China of \$2.9 million, \$0.7 million and \$0.4 million, respectively, and minority interest income of \$0.9 million. The after-tax cost of these items was \$6.9 million.
- (3) For the year ended December 31, 2006, net income includes the following net pre-tax gain: gain on sales of buildings of \$8.2 million, restructuring costs consisting primarily of European severance of \$2.2 million and amortization of \$0.4 million, other costs consisting of accelerated depreciation and severance in our Chinese joint venture of \$4.7 million and minority interest income of \$1.5 million. The after-tax gain of these items was \$1.5 million.
- (4) For the year ended December 31, 2005, net income includes the following pre-tax costs: restructuring of \$0.7 million and other costs consisting of accelerated depreciation and asset write-downs of \$1.8 million. The after-tax cost of these items was \$1.6 million.

- (5) For the year ended December 31, 2005, net income includes a net after-tax charge of \$0.9 million for a selling, general and administrative expense charge of \$1.5 million related to a contingent earn-out agreement.
- (6) For the year ended December 31, 2004, net income includes a net after-tax charge of \$2.3 million for certain accrued expense adjustments, which are included in selling, general and administrative expense after-tax charges of \$3.5 million related to a contingent earn-out agreement and \$0.7 million for various accrual adjustments and \$0.5 million recorded as an income tax benefit.
- (7) For the year ended December 31, 2004, net income includes the following pre-tax costs: restructuring of \$0.1 million and other costs consisting of accelerated depreciation of \$2.9 million. The after-tax cost of these items was \$1.8 million.
- (8) In December 2004, we decided to divest our interest in our minority-owned subsidiary, Jameco International, LLC (Jameco LLC). We recorded in discontinued operation a net of tax impairment charge of \$0.7 million for the year ended December 31, 2004. Also included in discontinued operations is the net of tax operating results of Jameco LLC of \$0.1 million of loss and \$0.1 million of income for the year ended December 31, 2004 and 2003, respectively. In September 1996, we divested our Municipal Water Group of businesses, which included Henry Pratt, James Jones Company and Edward Barber and Company Ltd. Costs and expenses related to the Municipal Water Group, for 2008, 2007, 2006, 2005 and 2004 relate to legal and settlement costs associated with the James Jones Litigation. The loss, net of taxes, consists of \$ 0.7 million, \$0.2 million, \$3.4 million, \$0.4 million and \$1.1 million for the years ended December 31, 2008, 2007, 2006, 2005 and 2004, respectively.

Item 7. MANAGEMENT'S DISCUSSION AND ANALYSIS OF FINANCIAL CONDITION AND RESULTS OF OPERATIONS.

Overview

We are a leading supplier of products for use in the water quality, water safety, water flow control and water conservation markets in both North America and Europe with an expanding presence in Asia. For over 130 years, we have designed and manufactured products that promote the comfort and safety of people and the quality and conservation of water used in commercial and residential applications. We earn revenue and income almost exclusively from the sale of our products. Our principal product lines include:

- water quality products, including backflow preventers and check valves for preventing reverse flow within water lines and fire protection systems and point-of-use water filtration and reverse osmosis systems for both commercial and residential applications;
- a wide range of water pressure regulators for both commercial and residential applications;
- drainage products for industrial, commercial, marine and residential applications;
- water supply products for commercial and residential applications;
- temperature and pressure relief valves for water heaters, boilers and associated systems;
- thermostatic mixing valves for tempering water in commercial and residential applications;
- systems for under-floor radiant applications and hydraulic pump groups for gas boiler manufacturers and renewable energy applications, including solar and heat pump control packages;
- flexible stainless steel connectors for natural and liquid propane gas in commercial food service and residential applications; and
- large diameter butterfly valves for use in China's water infrastructure.

Our business is reported in three geographic segments, North America, Europe and China. We distribute our products through three primary distribution channels, wholesale, do-it-yourself (DIY) and original equipment manufacturers (OEMs). Interest rates have an indirect effect on the demand for our products due to the effect such rates have on the number of new residential and commercial construction starts and remodeling projects. All three of these activities have an impact on our sales and earnings. An additional factor that has had an effect on our sales is fluctuation in foreign currencies, as a portion of our sales and certain portions of our costs, assets and liabilities are denominated in currencies other than the U.S. dollar.

We believe that the factors relating to our future growth include our ability to continue to make selective acquisitions, both in our core markets as well as in new complementary markets, regulatory requirements relating to the quality and conservation of water, increased demand for clean water with continued enforcement of plumbing and building codes and a healthy economic environment. We have completed 32 acquisitions since divesting our industrial and oil and gas business in 1999. Our acquisition strategy focuses on businesses that manufacture preferred brand name products that address our themes of water quality, water conservation, water safety and water flow control and related complementary markets. We target businesses that will provide us with one or more of the following: an entry into new markets, an increase in shelf space with existing customers, a new or improved technology or an expansion of the breadth of our water quality, water conservation, water safety and water flow control products for the residential and commercial markets. In 2008 and 2007, sales from acquisitions contributed approximately 4.6% and 3.9%, to our total sales growth over the prior year.

Products representing a majority of our sales are subject to regulatory standards and code enforcement, which typically require that these products meet stringent performance criteria. Together with our commissioned manufacturers' representatives, we have consistently advocated for the

development and enforcement of such plumbing codes. We are focused on maintaining stringent quality control and testing procedures at each of our manufacturing facilities in order to manufacture products in compliance with code requirements and take advantage of the resulting demand for compliant products. We believe that the product development, product testing capability and investment in plant and equipment needed to manufacture products in compliance with code requirements, represent a barrier to entry for competitors. We believe that, over the long term, there is an increasing demand among consumers for products to ensure water quality, which creates growth opportunities for our products.

Adverse economic developments in 2008 created a challenging environment for us. The credit crisis and recessionary pressures negatively impacted the primary markets we serve. We took steps during the year to reduce costs and conserve cash. During the fourth quarter of 2008, we reduced our workforce by 10% in the U.S. This step is expected to save us approximately \$10.0 million to \$11.0 million per year. In addition to the reduction in force, we took several steps to help conserve cash into 2009, including suspending our stock repurchase program, first freezing U.S. wages and salaries and later implementing salary reductions, controlling capital spending levels and continuing to focus on working capital levels. We also announced a further operational restructuring program to consolidate our manufacturing footprint in North America and China. We will continue to evaluate acquisition candidates during 2009, but we expect funds to be spent on acquisitions will be less than that spent in 2008. We are enhancing our focus on productivity and continuous improvement, and on managing our working capital levels as well as positioning many of our products to benefit when the market returns. We believe that we are well positioned to weather the current economic crisis due to our ability to continue to generate positive cash flows and control spending levels. We are not faced with any major liquidity events until 2010, at which time \$50.0 million of our debt will come due.

We require substantial amounts of raw materials to produce our products, including bronze, brass, cast iron, steel and plastic, and substantially all of the raw materials we require are purchased from outside sources. We have experienced volatility in the costs of certain raw materials, particularly copper. Bronze and brass are copper-based alloys. During the fourth quarter of 2008, prices of copper dropped from highs experienced less than nine months earlier.

A risk we face is our ability to deal effectively with changes in raw material costs. We manage this risk by monitoring related market prices, working with our suppliers to achieve the maximum level of stability in their costs and related pricing, seeking alternative supply sources when necessary, implementing cost reduction programs and passing increases in costs to our customers. Additionally from time to time we may use commodity futures contracts on a limited basis to manage this risk. We are not able to predict whether or for how long this volatility will continue. If costs continue to decrease, we may experience pressure from customers to reduce product pricing. We are unable to predict the timing and impact that these pricing decreases could have to our profit margins.

Another risk we face in all areas of our business is competition. We consider brand preference, engineering specifications, code requirements, price, technological expertise, delivery times and breadth of product offerings to be the primary competitive factors. As mentioned previously, we believe that the product development, product testing capability and investment in plant and equipment needed to manufacture products in compliance with code requirements, represent a barrier to entry for competitors. We are committed to maintaining our capital equipment at a level consistent with current technologies, and thus we spent approximately \$26.6 million in 2008 and \$37.8 million in 2007.

Recent Developments

On February 10, 2009, a plan was approved by the Board of Directors to expand our program to consolidate our manufacturing footprint in North America and China. The plan provides for the closure of three plants, with the relocation of those operations to existing facilities in either North America or China or to a new central facility in the United States.

The footprint consolidation pre-tax charge will be approximately \$11.7 million, including severance charges of approximately \$3.2 million, relocation costs of approximately \$3.3 million and asset write-downs of approximately \$5.2 million. We also expect to record a net gain on property sales of \$2.4 million. One-time tax charges of approximately \$7.0 million regarding the payback of prior tax holiday benefits are also expected to be incurred as part of the building relocations. Approximately 400 positions will be eliminated in connection with this consolidation. The net after tax charge for this manufacturing consolidation program is expected to be approximately \$14.9 million (\$4.4 million non cash), with costs being incurred through December 2009. We expect to spend approximately \$4.8 million in capital expenditures to consolidate operations. We expect this entire project will be self-funded through net proceeds from the sale of buildings and other assets being disposed of as part of the plan.

On February 9, 2009, we declared a quarterly dividend of eleven cents (\$0.11) per share on each outstanding share of Class A Common Stock and Class B Common Stock.

Results of Operations

Year Ended December 31, 2008 Compared to Year Ended December 31, 2007

Net Sales. Our business is reported in three geographic segments: North America, Europe and China. Our net sales in each of these segments for the years ended December 31, 2008 and 2007 were as follows:

	Year Ended December 31, 2008		Year Ended December 31, 2007		Change	Change to Consolidated Net Sales
	Net Sales	% Sales	Net Sales	% Sales		
	(Dollars in millions)					
North America	\$ 866.2	59.4%	\$ 871.0	63.0%	\$ (4.8)	(0.4)%
Europe	546.0	37.4	452.6	32.7	93.4	6.8
China	47.2	3.2	58.7	4.3	(11.5)	(0.8)
Total	<u>\$1,459.4</u>	<u>100.0%</u>	<u>\$1,382.3</u>	<u>100.0%</u>	<u>\$ 77.1</u>	<u>5.6%</u>

The change in net sales is attributable to the following:

					Change As a % of Consolidated Net Sales				Change As a % of Segment Net Sales		
	North America	Europe	China	Total	North America	Europe	China	Total	North America	Europe	China
	(Dollars in millions)										
Organic growth . . .	\$(18.2)	\$11.3	\$(12.1)	\$(19.0)	(1.3)%	0.8%	(0.9)%	(1.4)%	(2.1)%	2.5%	(20.6)%
Foreign exchange . .	0.5	31.3	3.8	35.6	—	2.3	0.3	2.6	—	6.9	6.5
Acquisitions	12.9	50.8	—	63.7	0.9	3.7	—	4.6	1.5	11.2	—
Disposal	—	—	(3.2)	(3.2)	—	—	(0.2)	(0.2)	—	—	(5.5)
Total	<u>\$ (4.8)</u>	<u>\$93.4</u>	<u>\$(11.5)</u>	<u>\$ 77.1</u>	<u>(0.4)%</u>	<u>6.8%</u>	<u>(0.8)%</u>	<u>5.6%</u>	<u>(0.6)%</u>	<u>20.6%</u>	<u>(19.6)%</u>

Organic net sales for 2008 decreased in North America primarily due to decreased sales in the wholesale market, where sales were 2.5% lower than in 2007. Unit sale declines, due in large part to the soft economy, were widespread across a number of product lines, with our backflow product line impacted the most. Organic sales in our North American retail market for 2008 remained relatively flat compared with 2007, decreasing 0.6%. Unit sale reductions in the retail market due to the soft economy were offset by selected price increases and new product rollouts. Given the current recession and more stringent bank lending standards, we believe that both the commercial and residential construction markets, which we sell into through our wholesale and DIY channels, will continue to be soft through 2009. As a result, we believe that our sales in North America may decline in 2009. Growth

in North America due to acquisitions is due to the inclusion of sales from Topway acquired in November 2007.

Organic net sales for 2008 increased in Europe primarily due to an 11.0% increase in sales into the European OEM market as compared to 2007. OEM sales were positively impacted in Germany where sales of our products into alternative energy and energy conservation markets were strong. Sales into the wholesale market for 2008 decreased by 4.5% as compared to 2007 and were negatively affected by declines in construction activity. Acquired sales growth in Europe was due to the inclusion of Blücher for seven months in 2008. We expect sales in Europe will increase on a constant currency basis in 2009 as Blücher will be reported for a full year and we expect alternative energy products sales to grow, offset by unit declines in our core product lines. Core sales are expected to be impacted by the widening recession in Europe.

Organic net sales for 2008 declined in China due to decreased sales in both the Chinese domestic and export markets. China sales were also negatively affected as compared to 2007 from the disposal of a commodity butterfly valve business during the fourth quarter of 2008. This decrease was partially offset by an increase in sales of large diameter butterfly valves to our water infrastructure customers during 2008.

The increases in net sales due to foreign exchange in North America, Europe and China were primarily due to the appreciation of the Canadian dollar, euro and yuan, respectively, against the U.S. dollar. We cannot predict whether these currencies will continue to appreciate against the U.S. dollar in future periods or whether future foreign exchange rate fluctuations will have a positive or negative impact on our net sales. Recent fluctuations in foreign currency rates portend a reduction in those currencies against the U.S. dollar.

Gross Profit. Gross profit and gross profit as a percent of net sales (gross margin) for 2008 and 2007 were as follows:

	<u>Year Ended December 31,</u>		<u>Point Change</u>
	<u>2008</u>	<u>2007</u>	
	(dollars in millions)		
Gross profit	\$488.4	\$461.6	
Gross margin	33.5%	33.4%	0.1%

Gross margin improved by 10 basis points to 33.5% in 2008 compared to 2007. The improvement was attributable primarily to margin improvements in North America and Europe offset by declines in China. North America's margin improved 70 basis points to 34.4% primarily due to the price increases implemented to offset prior raw material cost increases and, to a lesser extent, the mix of product sold. Further, 2007 North American gross margins were negatively impacted by approximately \$6.5 million, or approximately 100 basis points on the prior year gross margin, for charges associated with product discontinuances and a change in estimate for workers' compensation costs. Gross margin in Europe increased to 32.3% from 31.0% primarily due to our ability to leverage additional volume from alternative energy product sales with better factory absorption levels due to the rationalization efforts made over the last two years in Italy. China gross margin deteriorated when compared to 2007 primarily due to excess capacity due to sales declines, value added tax increases, negative impact from the increase in the value of the Chinese yuan against the U.S. dollar and disruptions from a plant move and labor disputes.

During 2007, we initiated a global restructuring program that was approved by our Board of Directors on October 30, 2007. The program includes plans to shut down five manufacturing facilities, right-size a sixth facility and incur costs to relocate one of our China facilities. In addition, we performed an evaluation of certain product lines in 2007. After completing this evaluation, we initiated a plan to discontinue certain product lines. In accordance with the restructuring program and product line discontinuance commenced in 2007, we anticipated spending \$12.9 million. To date, we have

incurred \$8.9 million of costs associated with the plans and have successfully shut down two manufacturing facilities and right sized another facility. Management is reviewing the status of the program and the timing of charges for the Europe segment. We anticipate the restructuring program will not be completed until 2010, with the expectation that our Europe segment will incur most of its costs during 2010. As such, previous estimates of savings from the programs will likely be achieved in 2010 rather than in the second half of 2009.

The following table presents the total estimated pre-tax charges to be incurred for the global restructuring program and product line discontinuances initiated in 2007 by our reportable segments and amounts charged to date:

<u>Reportable Segment</u>	<u>Total</u>	<u>Spent to Date</u>
	<u>(in millions)</u>	
North America	\$ 5.7	\$5.8
Europe	3.9	0.2
China	3.3	2.9
Total	<u>\$12.9</u>	<u>\$8.9</u>

Selling, General and Administrative Expenses. Selling, general and administrative expenses, or SG&A expenses, for 2008 increased \$27.5 million, or 8.3%, compared to 2007. The increase in SG&A expenses is attributable to the following:

	<u>(in millions)</u>	<u>% Change</u>
Organic growth	\$ 3.2	1.0%
Foreign exchange	7.7	2.3
Acquisitions	17.8	5.4
Disposal	<u>(1.2)</u>	<u>(0.4)</u>
Total	<u>\$27.5</u>	<u>8.3%</u>

The organic increase in SG&A expenses was primarily due to increased incentive compensation costs and increased variable European selling expenses due to increased sales volumes partially offset by decreased shipping costs and other variable North American selling expenses due to decreased sales volumes. The increase in SG&A expenses from foreign exchange was primarily due to the appreciation of the euro, yuan and Canadian dollar against the U.S. dollar. The increase in SG&A expenses from acquisitions was due to the inclusion of Blücher and Topway. Total SG&A expenses, as a percentage of sales, was 24.7% in 2008 compared to 24.1% 2007.

Restructuring and Other (Income) Charges. In 2008, we recorded \$5.6 million for severance, asset write-downs and accelerated depreciation in North America, China and Europe. In 2007, we recorded \$3.2 million for asset write-downs, accelerated depreciation and severance in North America and China.

Goodwill Impairment Charge. The goodwill impairment charge in 2008 of approximately \$22.0 million related to one of our North American reporting units (Water Quality). See Note 2 of notes to consolidated financial statements in this Annual Report on Form 10-K, for additional information regarding the impairment.

Operating Income. Operating income by geographic segment for 2008 and 2007 was as follows:

	Years Ended			% Change to Consolidated Operating Income
	December 31, 2008	December 31, 2007	Change	
	(Dollars in millions)			
North America	\$ 67.8	\$ 93.3	\$(25.5)	(20.3)%
Europe	65.7	53.6	12.1	9.6
China	(5.7)	7.9	(13.6)	(10.8)
Corporate	(27.2)	(29.1)	1.9	1.5
Total	<u>\$100.6</u>	<u>\$125.7</u>	<u>\$(25.1)</u>	<u>(20.0)%</u>

The change in operating income is attributable to the following:

	Change As a % of Consolidated Operating Income					Change As a % of Segment Operating Income								
	North America	Europe	China	Corp.	Total	North America	Europe	China	Corp.	Total				
	(Dollars in millions)													
Organic growth . . .	\$ (2.1)	\$ 5.7	\$(16.7)	\$1.9	\$(11.2)	(1.6)%	4.5%	(13.3)%	1.5%	(8.9)%	(2.3)%	10.6%	(211.4)%	6.5%
Foreign exchange . .	—	3.9	(0.4)	—	3.5	—	3.1	(0.2)	—	2.9	—	7.3	(5.1)	—
Acquisitions	(0.6)	2.7	—	—	2.1	(0.4)	2.1	—	—	1.7	(0.6)	5.0	—	—
Disposal	—	—	0.8	—	0.8	—	—	0.6	—	0.6	—	—	10.1	—
Restructuring, goodwill and other	(22.8)	(0.2)	2.7	—	(20.3)	(18.3)	(0.1)	2.1	—	(16.3)	(24.4)	(0.4)	34.2	—
Total	<u>\$(25.5)</u>	<u>\$12.1</u>	<u>\$(13.6)</u>	<u>\$1.9</u>	<u>\$(25.1)</u>	<u>(20.3)%</u>	<u>9.6%</u>	<u>(10.8)%</u>	<u>1.5%</u>	<u>(20.0)%</u>	<u>(27.3)%</u>	<u>22.5%</u>	<u>(172.2)%</u>	<u>6.5%</u>

The decrease in consolidated organic operating income was due primarily to underutilization of capacity, in both China and, to a lesser extent, in North America caused by recessionary unit volume declines and one-off events in China such as the labor strike, a plant move and natural disasters. Also, SG&A expenses such as salaries, product liability and other fixed spending increased. These items were partially offset by higher sales and better productivity in Europe and reductions in certain SG&A expenses such as shipping, pension costs and bad debts. Corporate costs decreased as the result of lower benefit costs, including lower stock based compensation and reduced costs from our nonqualified deferred compensation plan, and lower costs related to our Sarbanes Oxley compliance efforts and reduced legal costs.

The Blücher acquisition accounts for the net increase in operating profits from acquisitions.

The net increase in operating income from foreign exchange was primarily due to the appreciation of the euro against the U.S. dollar. We cannot predict whether these currencies will continue to appreciate against the U.S. dollar in future periods or whether future foreign exchange rate fluctuations will have a positive or negative impact on our operating income.

Interest Income. Interest income decreased \$9.4 million, or 64.8%, in 2008 compared to 2007, primarily due to cash used to fund the Blücher acquisition and the stock buy-back program initiated in November 2007, as well as, a lower interest rate environment in 2008 as compared to 2007.

Interest Expense. Interest expense decreased \$0.7 million, or 2.6% in 2008 compared to 2007, primarily due to lower outstanding balances on the revolving credit facility partially offset by an increase in the average variable rates charged on the revolving credit facility.

Other (Income) Expense. Other expense increased \$6.8 million, or 295.7%, in 2008 compared to 2007, primarily due to foreign currency transaction losses, losses on metal commodity transactions and negative changes in asset valuation of our nonqualified deferred compensation plan. Foreign currency transaction losses increased in China, Europe and Canada in 2008 as compared to 2007.

Income Taxes. Our effective tax rate for continuing operations increased to 34.6% for 2008 from 31.8% for 2007. The main driver of the increase was goodwill impairment. A portion of the goodwill relates to stock acquisitions, which when impaired is not tax deductible. Our European effective rate declined due to provision releases and favorable tax treatments related to the Blücher acquisition financing.

Income From Continuing Operations. Income from continuing operations in 2008 decreased \$30.3 million, or 39.0%, to \$47.3 million, or \$1.28 per common share, from \$77.6 million, or \$1.99 per common share, for 2007, in each case, on a diluted basis. Repurchased shares had an accretive impact of \$0.07 per common share in 2008. Income from continuing operations included an after-tax goodwill impairment charge of \$17.3 million, or \$0.47 per common share for 2008. Income from continuing operations for 2007 includes a tax refund of \$1.9 million, or \$0.05 per common share. Income from continuing operations for 2008 and 2007 included costs, net of tax, from our restructuring plan, reduction-in-force and product line discontinuances of \$3.9 million, or \$0.10 per common share, and \$5.1 million, or \$0.13 per common share, respectively. The appreciation of the euro, Chinese yuan and Canadian dollar against the U.S. dollar resulted in a positive impact on income from continuing operations of \$0.07 per common share for 2008 compared to the comparable period last year. We cannot predict whether the euro, Canadian dollar or yuan will appreciate or depreciate against the U.S. dollar in future periods or whether future foreign exchange rate fluctuations will have a positive or negative impact on our net income.

Loss From Discontinued Operations. Loss from discontinued operations in 2008 and 2007 was \$0.7 million, or \$0.02 per common share, and \$0.2 million, or \$0.01 per common share, on a diluted basis for the comparable period. The losses for 2008 and 2007 were primarily attributable to increased legal fees associated with the James Jones Litigation, as described in Part I, Item 1, "Business-Product Liability, Environmental and Other Litigation Matters." The 2007 loss was partially offset by reserve adjustments.

Year Ended December 31, 2007 Compared to Year Ended December 31, 2006

Net Sales. Our net sales in each of our three geographic segments for the years ended December 31, 2007 and 2006 were as follows:

	Year Ended December 31, 2007		Year Ended December 31, 2006		Change	Change to Consolidated Net Sales
	Net Sales	% Sales	Net Sales	% Sales		
	(Dollars in millions)					
North America	\$ 871.0	63.0%	\$ 821.3	66.7%	\$ 49.7	4.0%
Europe	452.6	32.7	367.5	29.9	85.1	6.9
China	58.7	4.3	42.0	3.4	16.7	1.4
Total	<u>\$1,382.3</u>	<u>100.0%</u>	<u>\$1,230.8</u>	<u>100.0%</u>	<u>\$151.5</u>	<u>12.3%</u>

The increase in net sales is attributable to the following:

					Change As a % of Consolidated Net Sales				Change As a % of Segment Net Sales		
	North America	Europe	China	Total	North America	Europe	China	Total	North America	Europe	China
	(Dollars in millions)										
Organic growth	\$41.0	\$13.7	\$ 8.5	\$ 63.2	3.3%	1.1%	0.7%	5.1%	5.0%	3.7%	20.3%
Foreign exchange	3.9	34.1	2.4	40.4	0.3	2.8	0.2	3.3	0.5	9.3	5.8
Acquisitions	4.8	37.3	5.8	47.9	0.4	3.0	0.5	3.9	0.6	10.2	13.8
Total	<u>\$49.7</u>	<u>\$85.1</u>	<u>\$16.7</u>	<u>\$151.5</u>	<u>4.0%</u>	<u>6.9%</u>	<u>1.4%</u>	<u>12.3%</u>	<u>6.1%</u>	<u>23.2%</u>	<u>39.9%</u>

The organic growth in net sales in North America was primarily due to increased unit selling prices and increased unit sales of certain product lines into the wholesale market. Our sales into the wholesale market in 2007, excluding the sales from the acquisition of Calflex Manufacturing, Inc. (Calflex) and Topway, grew by 7.7% compared to 2006. This was primarily due to increased sales of our backflow products. Our sales into the North American DIY market in 2007 decreased by 4.4% compared to 2006 primarily due our discontinuing certain lower margin product lines, partially offset by price increases and new product rollouts.

The acquired growth in net sales in North America was due to the inclusion of net sales of Calflex, acquired on June 2, 2006, and Topway, acquired on November 9, 2007.

The organic sales growth in Europe was broad-based, especially in Eastern Europe and in the OEM market, which was partially offset by a weak German market. Our sales into the wholesale and OEM markets in 2007, excluding the sales from the acquisitions of ATS Expansion Group (ATS), Kim Olofsson Safe Corporation (Kimsafe) and Black Teknigas, Limited (Teknigas), grew by 3.1% and 4.4%, respectively, compared to 2006.

The acquired growth in net sales in Europe was due to the inclusion of the net sales of ATS, acquired on May 19, 2006, Kimsafe, acquired on June 7, 2006, and Teknigas, acquired on August 14, 2006.

The organic sales growth in China was primarily due to increased export sales to Europe, increased sales into the domestic Chinese markets and the elimination of the one-month reporting lag in two of our Chinese entities.

The acquired growth in net sales in China was due to the inclusion of net sales of Changsha Valve Works (Changsha), acquired on April 26, 2006.

The increases in net sales due to foreign exchange in North America, Europe and China were primarily due to the appreciation of the Canadian dollar, euro and yuan, respectively, against the U.S. dollar.

Gross Profit. Gross profit and gross profit as a percent of net sales (gross margin) for 2007 and 2006 were as follows:

	Year Ended December 31,		Point Change
	2007	2006	
	(dollars in millions)		
Gross profit	\$461.6	\$425.0	
Gross margin	33.4%	34.5%	(1.1%)

Gross margin decreased in 2007 compared to 2006 primarily due to increased material costs, the write-off of inventory related to the discontinuance of certain product lines and an increase in our workers' compensation reserve primarily due to a change in estimate. The North American margin for 2007 was affected by a charge related to our discontinuance of certain product lines and for cost increases for copper-based alloys and stainless steel products, which exceeded realized sales price increases for most of the year. The European margin remained relatively flat primarily due to higher margins contributed by price increases that were offset by increased material costs and a shift in sales to lower margin products primarily in the OEM market. Our China segment's gross margin decreased primarily due to higher material costs, underutilized capacity in certain locations primarily due to the relocation of our joint venture facility, a charge related to our discontinuance of certain product lines, value added tax increases and a shift in product mix.

Selling, General and Administrative Expenses. SG&A expenses for 2007 increased \$32.5 million, or 10.8%, compared to 2006. The increase in SG&A expenses is attributable to the following:

	(in millions)	% Change
Organic growth	\$13.1	4.4%
Foreign exchange	7.9	2.6
Acquisitions	11.5	3.8
Total	<u>\$32.5</u>	<u>10.8%</u>

The organic increase in SG&A expenses was primarily due to increased product liability costs, increased stock-based compensation costs and increased variable selling expenses due to increased sales volumes partially offset by decreased incentive compensation costs. The increase in SG&A expenses from foreign exchange was primarily due to the appreciation of the euro, Canadian dollar and the yuan against the U.S. dollar. The increase in SG&A expenses from acquisitions was due to the inclusion of Changsha, ATS, Calflex, Watts Valve (Ningbo) Co, Ltd. (Ningbo), Kimsafe, Teknigas and Topway. Total SG&A expenses, as a percentage of sales, were 24.1% in 2007 compared to 24.4% 2006.

Restructuring and Other (Income) Charges. In 2007, we recorded \$3.2 million for asset write-downs, accelerated depreciation and severance in North America and China. In 2006, we recorded income of \$5.7 million primarily due to a gain of approximately \$8.2 million related to the sale of two buildings in Italy partially offset by a charge of \$2.5 million primarily for severance costs related to our European restructuring programs.

Operating Income. Operating income by geographic segment for 2007 and 2006 was as follows:

	Years Ended		Change	% Change to Consolidated Operating Income
	December 31, 2007	December 31, 2006		
	(Dollars in millions)			
North America	\$ 93.3	\$ 98.5	\$(5.2)	(4.0)%
Europe	53.6	50.0	3.6	2.8
China	7.9	7.2	0.7	0.5
Corporate	(29.1)	(25.2)	(3.9)	(3.0)
Total	<u>\$125.7</u>	<u>\$130.5</u>	<u>\$(4.8)</u>	<u>(3.7)%</u>

The change in operating income is attributable to the following:

	Change As a % of Consolidated Operating Income					Change As a % of Segment Operating Income				
	North America	Europe	China	Corp.	Total	North America	Europe	China	Corp.	Total
	(Dollars in millions)									
Organic growth . . .	\$(1.3)	\$ 0.9	\$(1.5)	\$(3.9)	\$(5.8)	(1.0)%	0.7%	(1.3)%	(3.0)%	(4.6)%
Foreign exchange . .	0.9	4.0	0.4	—	5.3	0.7	3.1	0.3	—	4.1
Acquisitions	(1.3)	4.8	0.8	—	4.3	(1.0)	3.6	0.7	—	3.3
Restructuring/other .	(3.5)	(6.1)	1.0	—	(8.6)	(2.7)	(4.6)	0.8	—	(6.5)
Total	<u>\$(5.2)</u>	<u>\$ 3.6</u>	<u>\$ 0.7</u>	<u>\$(3.9)</u>	<u>\$(4.8)</u>	<u>(4.0)%</u>	<u>2.8%</u>	<u>0.5%</u>	<u>(3.0)%</u>	<u>(3.7)%</u>
	<u>(1.4)%</u>	<u>1.8%</u>	<u>(20.8)%</u>	<u>(15.5)%</u>	<u>—</u>	<u>(5.3)%</u>	<u>7.2%</u>	<u>9.7%</u>	<u>(15.5)%</u>	<u>—</u>

The decrease in organic operating income in North America was primarily due to increased material costs partially offset by unit price increases, a net increase in our workers' compensation reserve primarily due to a change in estimate and increased product liability costs, partially offset by decreased incentive compensation costs. In 2007, we recorded a charge of \$3.1 million related to our discontinuance of certain product lines and \$0.4 million for primarily for severance costs related to our global restructuring program.

The acquired decrease was primarily due to the amortization of certain costs associated with the acquisition of Topway.

Europe's organic growth in operating income was due to our ability to leverage SG&A expenses, increased selling prices partially offset by increased material costs and a shift in sales to lower margin products primarily in the OEM market. In 2007, we did not record any costs associated with restructuring compared to a gain of \$6.0 million for the same period in 2006. We recorded a gain of \$8.2 million for the building sales in Italy partially offset by \$2.2 million of primarily severance costs.

The acquired growth in Europe was due to the inclusion of the operating income from ATS, Kimsafe and Teknigas.

The decrease in organic operating income in China was primarily attributable to decreased production levels at our wholly owned manufacturing plants. The acquired growth in China was due to the inclusion of the operating income of Changsha and Ningbo. In 2007, we recorded \$3.3 million for asset write-downs, accelerated depreciation and severance related to our global restructuring program and \$0.7 million related to our discontinuance of certain product lines. The elimination of a one-month reporting lag in two of our Chinese entities did not have a material impact on China's operating income.

The decrease in organic operating income in Corporate was primarily attributable to increased stock-based compensation costs and legal costs, partially offset by decreased incentive compensation costs.

The net increase in operating income from foreign exchange was primarily due to the appreciation of the euro, Canadian dollar and yuan against the U.S. dollar.

Interest Income. Interest income increased \$9.5 million, or 190.0%, in 2007 compared to 2006, primarily due to the investment of the net proceeds of approximately \$219.0 million from the public offering of 5.75 million shares of our Class A Common Stock in November 2006.

Interest Expense. Interest expense increased \$4.8 million, or 21.7%, in 2007 compared to 2006, primarily due to our April 27, 2006 issuance of \$225.0 million 5.85% senior notes due in 2016 and an increase in the average variable rates charged on the revolving credit facility partially offset by decreased debt levels for acquisitions.

Effective July 1, 2005, we entered into an interest rate swap for a notional amount of €25.0 million outstanding on our revolving credit facility. We swapped an adjustable rate of three month EURIBOR plus 0.6% for a fixed rate of 3.02%. We recorded a reduction to interest expense of approximately \$0.7 million to recognize the fair value of the swap for 2006. The swap was terminated on October 3, 2006.

Other (Income) Expense. Other (income) expense increased \$3.2 million, or 355.6% in 2007 compared to 2006, primarily due to currency movements and losses on forward currency contracts. Foreign currency losses were recorded in Europe, Canada and China in 2007, whereas foreign currency gains were recorded in 2006.

Minority interest. Minority interest increased \$1.0 million, or 55.6%, for 2007 compared to 2006, primarily due to the credit recorded for the 40% liability of our joint venture partner's share in the recording of the \$2.4 million TWT restructuring costs.

Income Taxes. Our effective tax rate for continuing operations decreased to 31.8% in 2007 from 33.6% in 2006. The decrease was primarily due to a one-time benefit associated with a refund of withholding taxes in Italy and in 2006 the recording of higher taxes on the sale of two buildings. This decrease was partially offset by the recording of a \$3.2 million valuation allowance on the deferred tax assets of our 60% owned Chinese joint venture.

Income From Continuing Operations. Income from continuing operations in 2007 increased \$0.5 million, or 0.6%, to \$77.6 million, or \$1.99 per common share, from \$77.1 million, or \$2.29 per

common share, for 2006, in each case, on a diluted basis. Income from continuing operations for 2007 included a tax refund of \$1.9 million, or \$0.05 per common share. Income from continuing operations for 2007 and 2006 included costs, net of tax, from our restructuring plan and product line discontinuances of \$5.1 million, or \$0.13 per common share, and included income, net of tax, of \$1.5 million, or \$0.04 per share, respectively. In 2006, the gains on the sales of our buildings in Italy resulted in an after-tax gain of \$5.1 million, or \$0.15 per share. The appreciation of the euro, Chinese yuan and Canadian dollar against the U.S. dollar resulted in a positive impact on income from continuing operations of \$0.09 per common share for 2007 compared to the comparable period last year.

Additionally, in November 2006, the Company completed a public offering of 5.75 million shares of Class A Common Stock and received net proceeds of approximately \$219.0 million. The interest earned on the net proceeds provided approximately \$7.1 million in after-tax income in 2007. The issuance of an additional 5.75 million shares had a dilutive impact on earnings per share of \$0.11 per share in 2007, after considering the interest income from the net proceeds.

Loss From Discontinued Operations. Loss from discontinued operations in 2007 and 2006 was \$0.2 million, or \$0.01 per common share, and \$3.4 million, or \$0.10 per common share, on a diluted basis for the comparable period. The losses for 2007 and 2006 were primarily attributable to increased deductible costs in 2006 and legal fees associated with the James Jones Litigation, as described in Part I, Item 1, "Business-Product Liability, Environmental and Other Litigation Matters." The 2007 loss was partially offset by reserve adjustments.

Liquidity and Capital Resources

We believe that effectively managing cash is necessary given the uncertainty in the current credit markets. To achieve our cash management goals and manage any potential downside liquidity events, we have taken steps to control spending, increase productivity, reduce net working capital levels, control capital expenditures and to spend more conservatively on acquisitions. With available cash of \$165.6 million at December 31, 2008, available capacity on our line of credit as discussed below, continued working capital management focus, no large debt payments due until 2010, and with spending and cost-cutting programs in place, we believe that we are well positioned to transition through what will be a challenging 2009. There are two recent negative developments related to inventory that could affect 2009 cash flows. We have recently experienced de-stocking issues within our customer base, which delay our ability to sell inventory. Further, more of our customers are adopting just-in-time inventory techniques to minimize their inventory investment, which puts pressure on our plants to hold inventory to meet expected near-term customer demand. Both these developments could affect our ability to reduce inventory levels during 2009 and, therefore could reduce our cash flows. Also, we may have to consider external sources of financing for any large future acquisitions.

In 2008, we generated \$146.4 million of cash from operating activities as compared to \$91.7 million in 2007. With management's enhanced focus in 2008 on working capital management, net working capital cash outflows have decreased from \$25.1 million in 2007, to a net working capital cash inflow of \$43.4 million in 2008, a \$68.5 million positive change. Better overall management of our inventory, accounts receivable and accounts payable drove the improvement in working capital. This change was offset to some extent by lower income from continuing operations.

We used \$172.2 million of net cash for investing activities in 2008. We used approximately \$167.9 million of net cash to fund a current year acquisition and spent \$9.3 million for acquisition costs related to prior years acquisitions. We received proceeds of \$33.3 million from the sale of auction rate securities. We invested \$26.6 million in capital equipment as part of our ongoing commitment to improve our manufacturing capabilities. We expect to invest approximately \$27.0 in capital equipment in 2009.

As of December 31, 2008, we held \$6.0 million in investments with an auction reset feature, or auction rate securities. Since December 31, 2007, we have reduced our exposure to auction rate

securities by \$30.6 million. We recorded an impairment of approximately \$2.4 million on the remaining securities in other expense in the Consolidated Statement of Operations, as the decline in fair value is no longer considered to be temporary. At the time of purchase, all the auction rate securities carried an AAA credit rating. The auction rate securities we currently hold are all long-term debt obligations secured by municipal bonds and student loans, and carry an AA or better credit rating.

Liquidity for these auction rate securities (ARS) is typically provided by an auction process, which allows holders to sell their notes, and resets the applicable interest rate at pre-determined intervals, usually every 7 to 35 days. Each of the auction rate securities in our investment portfolio as of December 31, 2008 has experienced failed auctions. There is no assurance that future auctions for these securities will succeed. During the fourth quarter of 2008, the Company and its broker elected to participate in a settlement offer by UBS AG (UBS). Under the terms of the settlement, the Company and its broker were issued rights by UBS. Each right entitles the holder to sell the underlying ARS at par to UBS at any time during the period June 30, 2010, through July 2, 2012. UBS could elect at any time from the settlement through the expiration of the settlement agreement to purchase the ARS, in which case UBS would be required to pay par value for the ARS. We have determined that the rights are a separate investment and have recorded the value of approximately \$2.3 million in other income in our Consolidated Statement of Operations. We have classified the investment in ARS and the UBS rights as long-term investments as we can not predict if UBS will purchase or sell the ARS before the earliest date at which we can require UBS to purchase the ARS at par.

We used \$92.4 million of net cash from financing activities in 2008. This was primarily due to payments for our stock repurchase program, payments of debt and dividend payments, partially offset by increased borrowings under our line of credit.

Our \$350.0 million revolving credit facility with a syndicate of banks is being used to support our acquisition program, working capital requirements and for general corporate purposes. Outstanding indebtedness under the revolving credit facility bears interest at a rate determined by the type of loan plus an applicable margin determined by our debt rating, depending on the applicable base rate and our bond rating. For 2008, the average interest rate under the revolving credit facility for euro-based borrowings was approximately 5.2%. There were no U.S. dollar borrowings at December 31, 2008. The revolving credit facility includes operational and financial covenants customary for facilities of this type, including, among others, restrictions on additional indebtedness, liens and investments and maintenance of certain leverage ratios. As of December 31, 2008, we were in compliance with all covenants related to the revolving credit facility, had \$260.0 million of unused and potentially available credit under the revolving credit facility and had \$55.0 million of euro-based borrowings outstanding and \$35.0 million for stand-by letters of credit outstanding on our revolving credit facility.

We used \$0.6 million of net cash from discontinued operations in 2008. We paid approximately \$1.2 million for defense and other legal costs we incurred in the James Jones Litigation. We also received \$1.3 million for reimbursements of defense costs.

Working capital (defined as current assets less current liabilities) as of December 31, 2008 was \$504.7 million compared to \$667.0 million as of December 31, 2007. This decrease was primarily due to decreases in cash and investment securities. Cash and cash equivalents decreased to \$165.6 million as of December 31, 2008 compared to \$290.3 million as of December 31, 2007 primarily due to funding of acquisitions and for payments for our stock repurchase program. The ratio of current assets to current liabilities was 2.7 to 1 as of December 31, 2008 compared to 3.3 to 1 as of December 31, 2007.

We generated \$91.7 million of cash from continuing operations in 2007. We experienced increases in inventory in North America and China. The increases were primarily due to increased raw material costs. There was also a decrease in accounts payable, accrued expenses and other liabilities, primarily in Europe and North America. In Europe, accounts payable declined in 2007 due to a decline in inventory. In North America, payments for cash compensation increased in 2007. Also, cash payments to cover income tax obligations were greater during 2007. Accounts receivable decreased in all three segments.

We used \$87.4 million of net cash for investing activities in 2007. We invested \$37.8 million in capital equipment as part of our ongoing commitment to improve our manufacturing capabilities. We invested \$27.5 million in investment grade auction rate securities. We used \$18.1 million to fund the acquisitions of Topway. We paid \$4.5 million for additional acquisition costs related to prior years acquisitions.

We used \$66.5 million of net cash from financing activities in 2007. This was primarily due to payments of debt, payments for our stock repurchase program and dividend payments, partially offset by increased borrowings under our line of credit and tax benefits from the exercise of stock awards.

We generated \$0.1 million of net cash from discontinued operations in 2007. We paid approximately \$0.5 million for defense costs and approximately \$0.5 million for other legal costs we incurred in the James Jones Litigation. We also received \$1.0 million for indemnity payments.

We generated \$83.0 million of cash from continuing operations for 2006. We experienced an increase in inventory and accounts receivable in North America, Europe and China. The increase in accounts receivable of \$17.0 million was primarily due to increased sales volume and selling prices. The increase in inventory of \$37.3 million was primarily due to increased cost of raw materials and planned increases in European safety stocks. The increase in inventory and accounts receivable was partially offset by increased accounts payable, accrued expenses and other liabilities of \$29.5 million.

We used \$119.2 million of net cash for investing activities in 2006. We used \$91.1 million to fund the acquisitions of Changsha, ATS, Calflex and Ningbo, Kimsafe and Teknigas, \$1.9 million in additional costs related to 2005 acquisitions and \$0.4 million to complete the planned increase of our ownership in Stern. We invested \$11.8 million in investment grade auction rate securities and \$44.7 million in capital equipment. Capital expenditures consisted of approximately \$26.7 million for manufacturing machinery and equipment and approximately \$18.0 million for the purchase of land and a building and for infrastructure improvements for a site in Italy. We subsequently entered into a sale-leaseback transaction with respect to the building. We received proceeds of \$31.9 million, which primarily included \$16.0 million related to the sale-leaseback in Italy and \$13.4 million from the sales of two facilities in northern Italy. We also received proceeds from two buildings held for sale, totaling approximately \$2.5 million during 2006.

We generated \$331.3 million of net cash from financing activities for 2006. On November 21, 2006, we completed a public offering of 5.75 million shares of newly issued Class A Common Stock at \$40.00 per share. Net proceeds were approximately \$218.6 million after taking into account underwriting discounts and expenses associated with the transaction. Additionally, we generated cash through the completion of our \$225.0 million private placement of 5.85% notes in April 2006, increased borrowings under our line of credit for use in Europe and proceeds from the exercise of stock options, partially offset by payments of debt, dividend payments and debt issue costs.

We generated \$0.9 million of net cash by operations from discontinued operations in 2006. We also received approximately \$2.8 million in cash for reimbursement of defense costs related to the James Jones Litigation. During 2006, we paid approximately \$0.6 million for defense costs and approximately \$0.5 million for indemnity costs we incurred in the James Jones Litigation.

We had free cash flow of \$120.9 million (a non-GAAP financial measure defined as net cash provided by continuing operations minus capital expenditures plus proceeds from sale of assets) during the year ended December 31, 2008 versus free cash flow of \$54.5 million in 2007. This increase in 2008 compared to 2007 was primarily due to growth in cash generated by operations from more focused working capital management. Our net debt to capitalization ratio (a non-GAAP financial measure defined as short and long-term interest-bearing liabilities less cash and cash equivalents as a percentage of the sum of short and long term interest-bearing liabilities less cash and cash equivalents plus total stockholders' equity) increased to 22.8% for 2008 from 13.5% for 2007. The increase resulted from the use of cash to purchase Blücher and for funds used in our stock repurchase program.

We had free cash flow of \$54.5 million during the year ended December 31, 2007 versus free cash flow of \$70.2 million in 2006. This decrease in 2007 compared to 2006 was primarily due to the proceeds from the sale of property, plant and equipment in 2006 partially offset by growth in cash generated by operations.

We believe free cash flow to be an appropriate supplemental measure of our operating performance because it provides investors with a measure of our ability to generate cash, to repay debt and to fund acquisitions. We may not be comparable to other companies that may define free cash flow differently. Free cash flow does not represent cash generated from operating activities in accordance with GAAP. Therefore it should not be considered an alternative to net cash provided by operations as an indication of our performance. Free cash flow should also not be considered an alternative to net cash provided by operations as defined by GAAP.

A reconciliation of net cash provided by continuing operations to free cash flow is provided below:

	Years Ended December 31,		
	2008	2007	2006
	(in millions)		
Net cash provided by continuing operations	\$146.4	\$ 91.7	\$ 83.0
Less: additions to property, plant, and equipment	(26.6)	(37.8)	(44.7)
Plus: proceeds from the sale of property, plant, and equipment	1.1	0.6	31.9
Free cash flow	<u>\$120.9</u>	<u>\$ 54.5</u>	<u>\$ 70.2</u>

Our net debt to capitalization ratio is also a non-GAAP financial measure used by management. Management believes it to be an appropriate supplemental measure because it helps investors understand our ability to meet our financing needs and as a basis to evaluate our financial structure. Our computation may not be comparable to other companies that may define net debt to capitalization differently.

A reconciliation of long-term debt (including current portion) to net debt and our net debt to capitalization ratio is provided below:

	December 31,	
	2008	2007
	(in millions)	
Current portion of long-term debt	\$ 4.5	\$ 1.3
Plus: long-term debt, net of current portion	409.8	432.2
Less: cash and cash equivalents	(165.6)	(290.3)
Net debt	<u>\$ 248.7</u>	<u>\$ 143.2</u>

A reconciliation of capitalization is provided below:

	December 31,	
	2008	2007
	(in millions)	
Net debt	\$ 248.7	\$ 143.2
Total stockholders' equity	842.4	915.5
Capitalization	<u>\$1,091.1</u>	<u>\$1,058.7</u>
Net debt to capitalization ratio	<u>22.8%</u>	<u>13.5%</u>

Our contractual obligations as of December 31, 2008 are presented in the following table:

<u>Contractual Obligations</u>	<u>Payments Due by Period</u>				
	<u>Total</u>	<u>Less than 1 year</u>	<u>1-3 years</u>	<u>3-5 years</u>	<u>More than 5 years</u>
			(in millions)		
Long-term debt obligations, including current maturities(a)	\$414.3	\$ 4.5	\$106.5	\$ 76.5	\$226.8
Operating lease obligations	26.0	7.7	7.9	4.3	6.1
Capital lease obligations(a)	14.6	1.3	2.8	2.5	8.0
Pension contributions	23.8	6.3	6.1	3.1	8.3
Interest(b)	129.6	22.6	39.5	33.4	34.1
Earnout payments(a)	0.4	0.4	—	—	—
Other(c)	29.7	25.3	2.0	1.2	1.2
Total	\$638.4	\$68.1	\$164.8	\$121.0	\$284.5

(a) as recognized in the consolidated balance sheet

(b) assumes the balance on the revolving credit facility remains at \$55.0 million and the interest rate remains at approximately 3.6% for the presented periods

(c) includes commodity, capital expenditure commitments and other benefits at December 31, 2008

We maintain letters of credit that guarantee our performance or payment to third parties in accordance with specified terms and conditions. Amounts outstanding were approximately \$39.3 million as of December 31, 2008 and \$45.0 million as of December 31, 2007. Our letters of credit are primarily associated with insurance coverage and to a lesser extent foreign purchases and generally expire within one year of issuance. These instruments may exist or expire without being drawn down, therefore they do not necessarily represent future cash flow obligations.

Off-Balance Sheet Arrangements

Except for operating lease commitments, we have no off-balance sheet arrangements that have or are reasonably likely to have a current or future effect on our financial condition, changes in financial condition, revenues or expenses, results of operations, liquidity, capital expenditures or capital resources that is material to investors.

Application of Critical Accounting Policies and Key Estimates

The preparation of our consolidated financial statements in accordance with U.S. GAAP requires management to make judgments, assumptions and estimates that affect the amounts reported. A critical accounting estimate is an assumption about highly uncertain matters and could have a material effect on the consolidated financial statements if another, also reasonable, amount were used, or, a change in the estimate is reasonably likely from period to period. We base our assumptions on historical experience and on other estimates that we believe are reasonable under the circumstances. Actual results could differ significantly from these estimates. There were no changes in accounting policies or significant changes in accounting estimates during 2008.

We periodically discuss the development, selection and disclosure of the estimates with our Audit Committee. Management believes the following critical accounting policies reflect its more significant estimates and assumptions.

Revenue recognition

We recognize revenue when all of the following criteria are met: (1) we have entered into a binding agreement, (2) the product has shipped and title has passed, (3) the sales price to the customer

is fixed or is determinable and (4) collectibility is reasonably assured. We recognize revenue based upon a determination that all criteria for revenue recognition have been met, which, based on the majority of our shipping terms, is considered to have occurred upon shipment of the finished product. Some shipping terms require the goods to be received by the customer before title passes. In those instances, revenues are not recognized until the customer has received the goods. We record estimated reductions to revenue for customer returns and allowances and for customer programs. Provisions for returns and allowances are made at the time of sale, derived from historical trends and form a portion of the allowance for doubtful accounts. Customer programs, which are primarily annual volume incentive plans, allow customers to earn credit for attaining agreed upon purchase targets from us. We record estimated reductions to revenue, made at the time of sale, for customer programs based on estimated purchase targets.

Allowance for doubtful accounts

The allowance for doubtful accounts is established to represent our best estimate of the net realizable value of the outstanding accounts receivable. The development of our allowance for doubtful accounts varies by region but in general is based on a review of past due amounts, historical write-off experience, as well as aging trends affecting specific accounts and general operational factors affecting all accounts. In North America, management specifically analyzes individual accounts receivable and establishes specific reserves against financially troubled customers. In addition, factors are developed utilizing historical trends in bad debts, returns and allowances. The ratio of these factors to sales on a rolling twelve-month basis is applied to total outstanding receivables (net of accounts specifically identified) to establish a reserve. In Europe, management develops their bad debt allowance through an aging analysis of all their accounts. In China, management specifically analyzes individual accounts receivable and establishes specific reserves as needed. In addition, for waterworks customers, whose payment terms are generally extended, we reserve the majority of accounts receivable in excess of one year from the invoice date.

We uniformly consider current economic trends and changes in customer payment terms when evaluating the adequacy of the allowance for doubtful accounts. We also aggressively monitor the creditworthiness of our largest customers, and periodically review customer credit limits to reduce risk. If circumstances relating to specific customers change or unanticipated changes occur in the general business environment, our estimates of the recoverability of receivables could be further adjusted.

Inventory valuation

Inventories are stated at the lower of cost or market with costs determined primarily on a first-in first-out basis. We utilize both specific product identification and historical product demand as the basis for determining our excess or obsolete inventory reserve. We identify all inventories that exceed a range of one to four years in sales. This is determined by comparing the current inventory balance against unit sales for the trailing twelve months. New products added to inventory within the past twelve months are excluded from this analysis. A portion of our products contain recoverable materials, therefore the excess and obsolete reserve is established net of any recoverable amounts. Changes in market conditions, lower than expected customer demand or changes in technology or features could result in additional obsolete inventory that is not saleable and could require additional inventory reserve provisions.

In certain countries, additional inventory reserves are maintained for potential shrinkage experienced in the manufacturing process. The reserve is established based on the prior year's inventory losses adjusted for any change in the gross inventory balance.

Goodwill and other intangibles

Goodwill and intangible assets with indefinite lives are tested annually for impairment in accordance with the provisions of Financial Accounting Standards Board Statement No. 142 "Goodwill

and Other Intangible Assets” (FAS 142). We use our judgment in assessing whether assets may have become impaired between annual impairment tests. Due to the current economic conditions as well as other business factors, we concluded that the goodwill of our Water Quality reporting unit was impaired on October 26, 2008, the time of our latest annual review. We recorded a charge of \$22.0 million in the fourth quarter in accordance with FAS 142. We perform our annual test for indicators of goodwill and non-amortizable intangible assets impairment in the fourth quarter of our fiscal year or sooner if indicators of impairment exist.

Intangible assets such as purchased technology are generally recorded in connection with a business acquisition. Values assigned to intangible assets are determined by an independent valuation firm based on our estimates and judgments regarding expectations of the success and life cycle of products and technology acquired.

We use a discounted cash flow method to determine the fair value of each reporting unit. We have eight reporting units, based on the guidance contained in FAS 142 and related literature. The discounted cash flow model includes a number of estimates of future cash flows. We develop our assumptions based on our historical results including sales growth, operating profits, working capital levels and tax rates. In our 2008 testing, we also incorporated assumptions regarding the current economic environment, including expectations regarding when the recession would end and at what point we would see orders return to historical levels.

We believe that the discounted cash flow model is sensitive to the selected discount rate. We use third-party experts to help develop appropriate discount rates for each reporting unit. We use standard valuation practices to arrive at a weighted average cost of capital based on the market and guideline public companies. The higher the discount rate, the lower the discounted cash flows. While we believe that our estimates of future cash flows are reasonable, different assumptions could significantly affect our valuations and result in impairments in the future.

Other changes that may affect our valuations include, but are not limited to, product acceptances and regulatory approval. If actual product acceptance differs significantly from our estimates, we may be required to record an impairment charge to write down the assets to their realizable value. A severe decline in market value could result in an unexpected impairment charge to goodwill, which could have a material impact on the results of operations and financial position. Although we have not experienced goodwill impairment in our remaining reporting units, there can be no assurances that future goodwill impairment will not occur.

Product liability and workers’ compensation costs

Because of retention requirements associated with our insurance policies, we are generally self-insured for potential product liability claims and for workers’ compensation costs associated with workplace accidents. For product liability cases in the U.S., management estimates expected settlement costs by utilizing loss reports provided by our third-party administrators as well as developing internal historical trend factors based on our specific claims experience. Management utilizes the internal trend factors that reflect final expected settlement costs. In other countries, we maintain insurance coverage with relatively high deductible payments, as product liability claims tend to be smaller than those experienced in the U.S. Changes in the nature of claims or the actual settlement amounts could affect the adequacy of this estimate and require changes to the provisions. Because the liability is an estimate, the ultimate liability may be more or less than reported.

Workers’ compensation liabilities in the U.S. are recognized for claims incurred (including claims incurred but not reported) and for changes in the status of individual case reserves. At the time a workers’ compensation claim is filed, a liability is estimated to settle the claim. The liability for workers’ compensation claims is determined based on management’s estimates of the nature and severity of the claims and based on analysis provided by third party administrators and by various state statutes and reserve requirements. We have developed our own trend factors based on our specific claims experience. In other countries where workers’ compensation costs are applicable, we maintain

insurance coverage with limited deductible payments. Because the liability is an estimate, the ultimate liability may be more or less than reported.

We determine the trend factors for product liability and workers' compensation liabilities based on consultation with outside actuaries.

We maintain excess liability insurance with outside insurance carriers to minimize our risks related to catastrophic claims in excess of all self-insured positions. Any material change in the aforementioned factors could have an adverse impact on our operating results.

Legal contingencies

We are a defendant in numerous legal matters including those involving environmental law and product liability as discussed further in Part I, Item 1, "Business—Product Liability, Environmental and Other Litigation Matters." As required by Statement of Financial Accounting Standards No. 5 "Accounting for Contingencies" (FAS 5), we determine whether an estimated loss from a loss contingency should be accrued by assessing whether a loss is deemed probable and the loss amount can be reasonably estimated, net of any applicable insurance proceeds. Estimates of potential outcomes of these contingencies are developed in consultation with outside counsel. While this assessment is based upon all available information, litigation is inherently uncertain and the actual liability to fully resolve this litigation cannot be predicted with any assurance of accuracy. Final resolution of these matters could possibly result in significant effects on our results of operations, cash flows and financial position.

Pension benefits

We account for our pension plans in accordance with Statement of Financial Accounting Standards No. 87 "Employers Accounting for Pensions" (FAS 87) and Statement of Financial Accounting Standards No. 158, "Employers' Accounting for Defined Benefit Pension and Other Postretirement Plans—an amendment of FASB Statements No. 87, 88, 106, and 132(R)," (FAS 158). In applying FAS 87 and FAS 158, assumptions are made regarding the valuation of benefit obligations and the performance of plan assets. The primary assumptions are as follows:

- Weighted average discount rate—this rate is used to estimate the current value of future benefits. This rate is adjusted based on movement in long-term interest rates.
- Expected long-term rate of return on assets—this rate is used to estimate future growth in investments and investment earnings. The expected return is based upon a combination of historical market performance and anticipated future returns for a portfolio reflecting the mix of equity, debt and other investments indicative of our plan assets.
- Rates of increase in compensation levels—this rate is used to estimate projected annual pay increases, which are used to determine the wage base used to project employees' pension benefits at retirement.

We determine these assumptions based on consultation with outside actuaries and investment advisors. Any variance in these assumptions could have a significant impact on future recognized pension costs, assets and liabilities.

Income taxes

We estimate and use our expected annual effective income tax rates to accrue income taxes. Effective tax rates are determined based on budgeted earnings before taxes, including our best estimate of permanent items that will affect the effective rate for the year. Management periodically reviews these rates with outside tax advisors and changes are made if material variances from expectations are identified.

We recognize deferred taxes for the expected future consequences of events that have been reflected in the consolidated financial statements in accordance with the rules of Statement of Financial Accounting Standards No. 109 "Accounting for Income Taxes" (FAS 109). Under FAS 109, deferred tax assets and liabilities are determined based on differences between the book values and tax bases of particular assets and liabilities, using tax rates in effect for the years in which the differences are expected to reverse. A valuation allowance is provided to offset any net deferred tax assets if, based upon the available evidence, it is more likely than not that some or all of the deferred tax assets will not be realized. We consider estimated future taxable income and ongoing prudent tax planning strategies in assessing the need for a valuation allowance.

On January 1, 2007, we adopted the provisions of Financial Interpretation No. 48 "Accounting for Uncertainty in Income Taxes" (FIN 48). The purpose of FIN 48 is to increase the comparability in financial reporting of income taxes. FIN 48 requires that in order for a tax benefit to be booked in the income statement, the item in question must meet the more-likely-than-not (greater than 50% likelihood of being sustained upon examination by the taxing authorities) threshold. The adoption of FIN 48 did not have a material effect on our financial statements. No cumulative effect was booked through beginning retained earnings.

During 2008, we reduced our unrecognized tax benefits by approximately \$2.2 million as a result of finalizing federal and state income tax audits. We estimate that it is reasonably possible that a portion of the currently remaining unrecognized tax benefit may be recognized by the end of 2009 as a result of the conclusion of the federal income tax audit. The amount of expense accrued for penalties and interest is \$1.1 million worldwide.

As of December 31, 2008, we had gross unrecognized tax benefits of approximately \$2.3 million of which, approximately \$1.9 million if recognized, would affect the effective tax rate. The difference between the amount of unrecognized tax benefits and the amount that would impact the effective tax rate consists of the federal tax benefit of state income tax items.

New Accounting Standards

In June 2008, the Financial Accounting Standards Board (FASB) issued FASB Staff Position (FSP) EITF Issue No. 03-6-1, "Determining Whether Instruments Granted in Share-Based Payment Transactions Are Participating Securities" (FSP EITF 03-6-1). FSP EITF 03-6-1 requires that unvested share-based payment awards that contain rights to receive non-forfeitable dividends or dividend equivalents to be included in the two-class method of computing earnings per share as described in Statement of Financial Accounting Standards (FAS) No. 128, "Earnings per Share." This FSP is effective for financial statements issued for fiscal years beginning after December 15, 2008, and interim periods within those years. Accordingly, we will adopt FSP EITF 03-6-1 in fiscal year 2009. The adoption of FSP EITF 03-6-1 is not expected to have a material impact on our consolidated financial statements.

In May 2008, the FASB issued FAS No. 162, "The Hierarchy of Generally Accepted Principles," (FAS 162), which identifies the sources of accounting principles and the framework for selecting the principles to be used in the preparation of financial statements of nongovernmental entities that are presented in conformity with generally accepted accounting principles (GAAP) in the United States (the GAAP hierarchy). FAS 162 is effective 60 days following the SEC's approval of the Public Company Accounting Oversight Board amendments to AU Section 411, "The Meaning of Present Fairly in Conformity With Generally Accepted Accounting Principles." The adoption of FAS 162 is not expected to have an impact on our consolidated financial statements.

In April 2008, the FASB issued FSP No. FAS 142-3, "Determination of the Useful Life of Intangible Assets." This FSP amends the factors that should be considered in developing renewal or extension assumptions used to determine the useful life of a recognized intangible asset under FAS No. 142, "Goodwill and Other Intangible Assets" (FAS 142). The objective of this FSP is to improve the consistency between the useful life of a recognized intangible asset under FAS 142 and the period

of expected cash flows used to measure the fair value of the asset under FAS 141(R), and other principles of GAAP. This FSP applies to all intangible assets, whether acquired in a business combination or otherwise, and shall be effective for financial statements issued for fiscal years beginning after December 15, 2008, and interim periods within those fiscal years and applied prospectively to intangible assets acquired after the effective date. Early adoption is prohibited. The adoption of this FSP will not have a significant impact on our consolidated financial statements.

In March 2008, the FASB issued FAS No. 161, “Disclosures about Derivative Instruments and Hedging Activities—an amendment of FASB Statement No. 133,” (FAS 161), which expands the current disclosure requirements of FAS 133, “Accounting for Derivative Instruments and Hedging Activities,” such that entities must now provide enhanced disclosures on a quarterly basis regarding how and why the entity uses derivatives; how derivatives and related hedged items are accounted for under FAS 133 and how derivatives and related hedged items affect the entity’s financial position, performance and cash flow. FAS 161 is effective prospectively for annual and interim periods beginning on or after November 15, 2008. Accordingly, we will adopt FAS 161 in 2009.

In December 2007, the FASB issued FAS No. 141 (R),” Business Combinations,” (FAS 141R), which requires most identifiable assets, liabilities, non-controlling interests, and goodwill acquired in a business combination to be recorded at “full fair value.” Under FAS 141R, all business combinations will be accounted for under the acquisition method. Significant changes, among others, from current guidance resulting from FAS 141R includes the requirement that contingent assets and liabilities and contingent consideration shall be recorded at estimated fair value as of the acquisition date, with any subsequent changes in fair value charged or credited to earnings. Further, acquisition-related costs will be expensed rather than treated as part of the acquisition. FAS 141R is effective for periods beginning on or after December 15, 2008. We expect the adoption of FAS 141R will increase costs charged to operations made after January 1, 2009.

In December 2007, the FASB issued FAS No. 160, “Non-controlling Interests in Consolidated Financial Statements, an amendment of ARB NO. 151,” (FAS 160), which requires non-controlling interests (previously referred to as minority interest) to be treated as a separate component of equity, not outside of equity as is current practice. FAS 160 applies to non-controlling interests and transactions with non-controlling interest holders in consolidated financial statements. FAS 160 is effective for periods beginning on or after December 15, 2008. We do not expect the adoption of FAS 160 will have a material impact on its consolidated financial statements.

In February 2007, the FASB issued FAS No. 159, “The Fair Value Option for Financial Assets and Financial Liabilities—including an Amendment to FAS No. 115,” (FAS 159), which permits entities to choose to measure many financial instruments and certain other items at fair value. FAS 159 is effective for financial statements issued for fiscal years beginning after November 15, 2007 and interim periods within those fiscal years. Earlier application is encouraged. We have elected not to measure our eligible financial instruments at fair value and therefore the adoption of FAS 159 did not have an impact on our consolidated financial statements.

In September 2006, the Securities and Exchange Commission issued Staff Accounting Bulletin No. 108, “Considering the Effects of Prior Year Misstatements When Quantifying Misstatements in Current Year Financial Statements” (SAB 108), which provides interpretive guidance on how the effects of the carryover or reversal of prior year misstatements should be considered in quantifying a current year misstatement. SAB 108 is effective for fiscal years ending after November 15, 2006. The impact of SAB 108 was not material to our consolidated financial statements.

In September 2006, the FASB issued FAS No. 158, “Employers’ Accounting for Defined Benefit Pension and Other Postretirement Plans—an amendment of FASB Statements No. 87, 88, 106, and 132(R)” (FAS 158), which requires an employer to: (a) recognize in its statement of financial position an asset for a plan’s overfunded status or a liability for a plan’s underfunded status; (b) measure a plan’s assets and its obligations that determine its funded status as of the end of the employer’s fiscal year; and (c) recognize changes in the funded status of a defined benefit postretirement plan in the

year in which the changes occur. Those changes are reported in other comprehensive income. The requirement to recognize the funded status of a benefit plan and the disclosure requirements are effective as of the end of the fiscal year ending after December 15, 2006 for companies with publicly traded equity securities. The requirement to measure plan assets and benefit obligations as of the date of the employer's fiscal year-end statement of financial position is effective for fiscal years ending after December 15, 2008, although earlier adoption is permitted. As a result of the requirement to recognize the funded status of our benefit plans as of December 31, 2006, we recorded an increase in our pension liability of approximately \$8.3 million, a decrease of approximately \$1.3 million in other assets: other, net and a decrease in accumulated other comprehensive income of approximately \$5.8 million, net of tax. We have early-adopted the measurement date provisions of FAS 158 effective January 1, 2007. Our pension plans previously used a September 30 measurement date. All plans are now measured as of December 31, consistent with our fiscal year end. The non-cash effect of the adoption of the measurement date provisions of FAS 158 was not material and there was no effect on our results of operations.

In September 2006, the FASB issued FAS No. 157, "Fair Value Measurements," (FAS 157), which defines fair value, establishes guidelines for measuring fair value and expands disclosures regarding fair value measurements. FAS 157 does not require any new fair value measurements but rather eliminates inconsistencies in guidance found in various prior accounting pronouncements and was effective for fiscal years beginning after November 15, 2007. In February 2008, the FASB issued FASB FSP 157-2 which delayed the effective date of FAS 157 for all nonfinancial assets and nonfinancial liabilities, except those that are recognized or disclosed at fair value in the financial statements on a recurring basis (at least annually), until fiscal years beginning after November 15, 2008, and interim periods within those fiscal years. These nonfinancial items include assets and liabilities such as reporting units measured at fair value in a goodwill impairment test and nonfinancial assets acquired and liabilities assumed in a business combination. Effective January 1, 2008, we adopted FAS 157 for financial assets and liabilities recognized at fair value on a recurring basis. The partial adoption of FAS 157 for financial assets and liabilities did not have a material impact on our consolidated financial position, results of operations or cash flows.

In July 2006, the FASB issued Financial Interpretation No. 48, "Accounting for Uncertainty in Income Taxes" (FIN 48), which clarifies the accounting for uncertainty in income taxes recognized in the financial statements in accordance with SFAS No. 109, "Accounting for Income Taxes." FIN 48 provides that a tax benefit from an uncertain tax position may be recognized when it is more likely than not that the position will be sustained upon examination, based on the technical merits. This interpretation also provides guidance on measurement, de-recognition, classification, interest and penalties, accounting in interim periods, disclosure and transition. We adopted the provisions of FIN 48 as of January 1, 2007 and the impact was not material to our consolidated financial statements.

In March 2006, the FASB issued FAS No. 156, "Accounting for Servicing of Financial Assets—an amendment of FASB Statement No. 140" (FAS 156). FAS 156 amends FAS Statement No. 140, "Accounting for Transfers and Servicing of Financial Assets and Extinguishments of Liabilities," with respect to the accounting for separately recognized servicing assets and servicing liabilities. FAS 156 addresses the recognition and measurement of separately recognized servicing assets and liabilities and provides an approach to simplify efforts to obtain hedge-like (offset) accounting. We adopted FAS 156 as of January 1, 2007 and the impact was not material to our consolidated financial statements.

In February 2006, the FASB issued FAS No. 155, "Accounting for Certain Hybrid Financial Instruments—an amendment of FASB Statements No. 133 and 140" (FAS 155). FAS 155 amends FAS 133, "Accounting for Derivatives and Hedging Activities," and FAS 140, "Accounting for Transfers and Servicing of Financial Assets and Extinguishments of Liabilities," and allows an entity to remeasure at fair value a hybrid financial instrument that contains an embedded derivative that otherwise would require bifurcation from the host, if the holder irrevocably elects to account for the whole instrument on a fair value basis. Subsequent changes in the fair value of the instrument would be recognized in

earnings. We adopted FAS 155 as of January 1, 2007 and the impact was not material to our consolidated financial statements.

Item 7A. QUANTITATIVE AND QUALITATIVE DISCLOSURES ABOUT MARKET RISK.

We use derivative financial instruments primarily to reduce exposure to adverse fluctuations in foreign exchange rates, interest rates and costs of certain raw materials used in the manufacturing process. We do not enter into derivative financial instruments for trading purposes. As a matter of policy, all derivative positions are used to reduce risk by hedging underlying economic exposure. The derivatives we use are instruments with liquid markets.

Our consolidated earnings, which are reported in United States dollars, are subject to translation risks due to changes in foreign currency exchange rates. This risk is concentrated in the exchange rate between the U.S. dollar and the euro; the U.S. dollar and the Canadian dollar; and the U.S. dollar and the Chinese yuan.

Our foreign subsidiaries transact most business, including certain intercompany transactions, in foreign currencies. Such transactions are principally purchases or sales of materials and are denominated in European currencies or the U.S. or Canadian dollar. We use foreign currency forward exchange contracts to manage the risk related to intercompany purchases that occur during the course of a year and certain open foreign currency denominated commitments to sell products to third parties. For 2008, the amounts recorded in other income for the change in the fair value of such contracts was immaterial.

We have historically had a low exposure on the cost of our debt to changes in interest rates. Information about our long-term debt including principal amounts and related interest rates appears in Note 11 of notes to the consolidated financial statements in our Annual Report on Form 10-K for the year ended December 31, 2008.

We purchase significant amounts of bronze ingot, brass rod, cast iron, steel and plastic, which are utilized in manufacturing our many product lines. Our operating results can be adversely affected by changes in commodity prices if we are unable to pass on related price increases to our customers. We manage this risk by monitoring related market prices, working with our suppliers to achieve the maximum level of stability in their costs and related pricing, seeking alternative supply sources when necessary and passing increases in commodity costs to our customers, to the maximum extent possible, when they occur.

During 2008, we entered into a series of copper swap contracts to fix the price per pound of copper for one customer. These swaps are classified as economic hedges, as more fully explained in Note 16 of notes to the consolidated financial statements. For the period ended December 31, 2008, we recorded \$1.8 million in losses associated with the copper swaps in other expense. We believe that if copper prices continue to decrease that the open copper swap contracts will result in additional losses that may occur in a period different from when that cost is recovered from the customer.

The Company used a discounted cash flow model for determining the value of the ARS and the UBS rights. As there is no active market for the ARS and the rights are non-transferable, we believe that the discounted cash flow model gives the best estimate of fair value at December 31, 2008. The model includes assumptions that are more fully explained in Note 16 of notes to the consolidated financial statements. The most sensitive of these assumptions is the illiquidity spread. We engaged valuation experts to develop the models. The illiquidity spread increases the discount rate, thereby decreasing the estimated fair value. To value the rights issued by UBS, we used a discounted cash flow model to estimate the fair value of the ARS with the rights. The value of the rights was determined by looking at the difference between the ARS as determined compared to the ARS with the rights. While we believe the assumptions used are consistent with the current market view on the ARS and are reasonable, different assumptions could significantly affect our valuation of ARS.

Item 8. FINANCIAL STATEMENTS AND SUPPLEMENTARY DATA.

The financial statements listed in section (a) (1) of “Part IV, Item 15. Exhibits and Financial Statement Schedules” of this annual report are incorporated herein by reference.

Item 9. CHANGES IN AND DISAGREEMENTS WITH ACCOUNTANTS ON ACCOUNTING AND FINANCIAL DISCLOSURE.

None.

Item 9A. CONTROLS AND PROCEDURES.

As required by Rule 13a-15(b) under the Securities Exchange Act of 1934, as of the end of the period covered by this report, we carried out an evaluation under the supervision and with the participation of our management, including our Chief Executive Officer and Chief Financial Officer, of the effectiveness of our disclosure controls and procedures. In designing and evaluating our disclosure controls and procedures, we recognize that any controls and procedures, no matter how well designed and operated, can provide only reasonable assurance of achieving the desired control objectives, and our management necessarily applies its judgment in evaluating and implementing possible controls and procedures. The effectiveness of our disclosure controls and procedures is also necessarily limited by the staff and other resources available to us and the geographic diversity of our operations. Based upon that evaluation, the Chief Executive Officer and Chief Financial Officer concluded that, as of the end of the period covered by this report, our disclosure controls and procedures were effective, in that they provide reasonable assurance that information required to be disclosed by us in the reports we file or submit under the Exchange Act is recorded, processed, summarized and reported within the time periods specified in the Securities and Exchange Commission’s rules and forms and are designed to ensure that information required to be disclosed by us in the reports that we file or submit under the Exchange Act are accumulated and communicated to our management, including our Chief Executive Officer and Chief Financial Officer, as appropriate to allow timely decisions regarding required disclosure. There was no change in our internal control over financial reporting that occurred during the quarter ended December 31, 2008, that has materially affected, or is reasonably likely to materially affect, our internal control over financial reporting. In connection with these rules, we will continue to review and document our disclosure controls and procedures, including our internal control over financial reporting, and may from time to time make changes aimed at enhancing their effectiveness and to ensure that our systems evolve with our business.

Management's Annual Report on Internal Control Over Financial Reporting

Management of the Company is responsible for establishing and maintaining adequate internal control over financial reporting as defined in Rules 13a-15(f) and 15d-15(f) under the Securities Exchange Act of 1934. The Company's internal control over financial reporting is designed to provide reasonable assurance regarding the reliability of financial reporting and the preparation of financial statements for external purposes in accordance with generally accepted accounting principles. The Company's internal control over financial reporting includes those policies and procedures that:

- (i) pertain to the maintenance of records that, in reasonable detail, accurately and fairly reflect the transactions and dispositions of the assets of the Company;
- (ii) provide reasonable assurance that transactions are recorded as necessary to permit preparation of financial statements in accordance with generally accepted accounting principles, and that receipts and expenditures of the Company are being made only in accordance with authorizations of management and directors of the Company; and
- (iii) provide reasonable assurance regarding prevention or timely detection of unauthorized acquisition, use or disposition of the Company's assets that could have a material effect on the financial statements.

Because of its inherent limitations, internal control over financial reporting may not prevent or detect misstatements. Also, projections of any evaluation of effectiveness to future periods are subject to the risk that controls may become inadequate because of changes in conditions, or that the degree of compliance with the policies or procedures may deteriorate.

Management, including our Chief Executive Officer and Chief Financial Officer, assessed the effectiveness of the Company's internal control over financial reporting as of December 31, 2008. In making this assessment, management used the criteria set forth by the Committee of Sponsoring Organizations of the Treadway Commission (COSO) in Internal Control—Integrated Framework.

Based on our assessment and those criteria, management believes that the Company maintained effective internal control over financial reporting as of December 31, 2008.

The audited consolidated financial statements of the Company include the results of Blücher Metal A/S and its subsidiaries, which the Company acquired on May 30, 2008, but management's assessment does not include an assessment of the internal control over financial reporting of these entities.

The independent registered public accounting firm that audited the Company's consolidated financial statements included elsewhere in this Annual Report on Form 10-K has issued an attestation report on the Company's internal control over financial reporting. That report appears immediately following this report.

Report of Independent Registered Public Accounting Firm

The Board of Directors and Stockholders
Watts Water Technologies, Inc.:

We have audited Watts Water Technologies, Inc.'s internal control over financial reporting as of December 31, 2008, based on criteria established in *Internal Control—Integrated Framework* issued by the Committee of Sponsoring Organizations of the Treadway Commission (COSO). Watts Water Technologies, Inc.'s management is responsible for maintaining effective internal control over financial reporting and for its assessment of the effectiveness of internal control over financial reporting, included in the accompanying *Management's Annual Report on Internal Control Over Financial Reporting*. Our responsibility is to express an opinion on the Company's internal control over financial reporting based on our audit.

We conducted our audit in accordance with the standards of the Public Company Accounting Oversight Board (United States). Those standards require that we plan and perform the audit to obtain reasonable assurance about whether effective internal control over financial reporting was maintained in all material respects. Our audit included obtaining an understanding of internal control over financial reporting, assessing the risk that a material weakness exists, and testing and evaluating the design and operating effectiveness of internal control based on the assessed risk. Our audit also included performing such other procedures as we considered necessary in the circumstances. We believe that our audit provides a reasonable basis for our opinion.

A company's internal control over financial reporting is a process designed to provide reasonable assurance regarding the reliability of financial reporting and the preparation of financial statements for external purposes in accordance with generally accepted accounting principles. A company's internal control over financial reporting includes those policies and procedures that (1) pertain to the maintenance of records that, in reasonable detail, accurately and fairly reflect the transactions and dispositions of the assets of the company; (2) provide reasonable assurance that transactions are recorded as necessary to permit preparation of financial statements in accordance with generally accepted accounting principles, and that receipts and expenditures of the company are being made only in accordance with authorizations of management and directors of the company; and (3) provide reasonable assurance regarding prevention or timely detection of unauthorized acquisition, use, or disposition of the company's assets that could have a material effect on the financial statements.

Because of its inherent limitations, internal control over financial reporting may not prevent or detect misstatements. Also, projections of any evaluation of effectiveness to future periods are subject to the risk that controls may become inadequate because of changes in conditions, or that the degree of compliance with the policies or procedures may deteriorate.

In our opinion, Watts Water Technologies, Inc. maintained, in all material respects, effective internal control over financial reporting as of December 31, 2008, based on criteria established in *Internal Control—Integrated Framework* issued by the Committee of Sponsoring Organizations of the Treadway Commission.

Watts Water Technologies, Inc. acquired Blücher Metal A/S and subsidiaries during 2008, and management excluded from its assessment of the effectiveness of Watts Water Technologies, Inc.'s internal control over financial reporting as of December 31, 2008, Blücher Metal A/S and subsidiaries' internal control over financial reporting associated with total assets of \$190.3 million and total revenues of \$50.8 million included in the consolidated financial statements of Watts Water Technologies, Inc. and subsidiaries as of and for the year ended December 31, 2008. Our audit of internal control over financial reporting of Watts Water Technologies, Inc. also excluded an evaluation of the internal control over financial reporting of Blücher Metal A/S and subsidiaries.

We also have audited, in accordance with the standards of the Public Company Accounting Oversight Board (United States), the consolidated balance sheets of Watts Water Technologies, Inc. and subsidiaries as of December 31, 2008 and 2007, and the related consolidated statements of operations,

stockholders' equity, and cash flows for each of the years in the three-year period ended December 31, 2008, and our report dated February 27, 2009 expressed an unqualified opinion on those consolidated financial statements.

KPMG LLP

Boston, Massachusetts
February 27, 2009

Item 9B. OTHER INFORMATION.

None.

PART III

Item 10. DIRECTORS, EXECUTIVE OFFICERS AND CORPORATE GOVERNANCE.

Information with respect to the executive officers of the Company is set forth in Part I, Item 1 of this Report under the caption “Executive Officers and Directors” and is incorporated herein by reference. The information provided under the captions “Information as to Nominees for Director,” “Corporate Governance,” and “Section 16(a) Beneficial Ownership Reporting Compliance” in our definitive Proxy Statement for our 2009 Annual Meeting of Stockholders to be held on May 13, 2009 is incorporated herein by reference.

We have adopted a Code of Business Conduct and Ethics applicable to all officers, employees and Board members. The Code of Business Conduct and Ethics is posted in the Investor Relations section of our website, www.wattswater.com. We will provide you with a print copy of our Code of Business Conduct and Ethics free of charge on written request to Kenneth R. Lepage, Secretary, Watts Water Technologies, Inc., 815 Chestnut Street, North Andover, MA 01845. Any amendments to, or waivers of, the Code of Business Conduct and Ethics which apply to our chief executive officer, chief financial officer, corporate controller or any person performing similar functions will be disclosed on our website promptly following the date of such amendment or waiver.

Item 11. EXECUTIVE COMPENSATION.

The information provided under the captions “Director Compensation,” “Corporate Governance,” “Compensation Discussion and Analysis,” “Executive Compensation,” “Compensation Committee Interlocks and Insider Participation,” and “Compensation Committee Report” in our definitive Proxy Statement for our 2009 Annual Meeting of Stockholders to be held on May 13, 2009 is incorporated herein by reference.

The “Compensation Committee Report” contained in our Proxy Statement shall not be deemed “soliciting material” or “filed” with the Securities and Exchange Commission or otherwise subject to the liabilities of Section 18 of the Securities Exchange Act of 1934, nor shall it be deemed incorporated by reference in any filings under the Securities Act of 1933 or the Exchange Act, except to the extent we specifically request that such information be treated as soliciting material or specifically incorporate such information by reference into a document filed under the Securities Act or Exchange Act.

Item 12. SECURITY OWNERSHIP OF CERTAIN BENEFICIAL OWNERS AND MANAGEMENT AND RELATED STOCKHOLDER MATTERS.

The information appearing under the caption “Principal Stockholders” in the Registrant’s Proxy Statement relating to the 2009 Annual Meeting of Stockholders to be held on May 13, 2009 is incorporated herein by reference.

Securities Authorized for Issuance Under Equity Compensation Plans

The following table provides information as of December 31, 2008, about the shares of Class A Common Stock that may be issued upon the exercise of stock options issued under the Company’s 2004 Stock Incentive Plan, 1991 Directors’ Non-Qualified Stock Option Plan, 1996 Stock Option Plan and 2003 Non-Employee Directors’ Stock Option Plan and the settlement of restricted stock units

granted under our Management Stock Purchase Plan as well as the number of shares remaining for future issuance under our 2004 Stock Incentive Plan and Management Stock Purchase Plan.

Plan Category	Equity Compensation Plan Information		Number of securities remaining available for future issuance under equity compensation plan (excluding securities reflected in column (a)) (c)
	Number of securities to be issued upon exercise of outstanding options, warrants and rights (a)	Weighted-average exercise price of outstanding options, warrants and rights (b)	
Equity compensation plans approved by security holders	1,513,106(1)	\$25.24	2,827,218(2)
Equity compensation plans not approved by security holders . .	None	None	None
Total	1,513,106(1)	\$25.24	2,827,218(2)

(1) Represents 1,216,471 outstanding options under the 1991 Directors' Non-Qualified Stock Option Plan, 1996 Incentive Stock Option Plan, 2003 Non-Employee Directors' Stock Option Plan and 2004 Stock Incentive Plan, and 296,635 outstanding restricted stock units under the Management Stock Purchase Plan.

(2) Includes 1,864,393 shares available for future issuance under the 2004 Stock Incentive Plan, and 962,825 shares available for future issuance under the Management Stock Purchase Plan.

Item 13. CERTAIN RELATIONSHIPS AND RELATED TRANSACTIONS, AND DIRECTOR INDEPENDENCE.

The information provided under the captions "Corporate Governance" and "Policies and Procedures for Related Person Transactions" in our definitive Proxy Statement for our 2009 Annual Meeting of Stockholders to be held on May 13, 2009 is incorporated herein by reference.

Item 14. PRINCIPAL ACCOUNTANT FEES AND SERVICES.

The information provided under the caption "Ratification of Independent Registered Public Accounting Firm" in our definitive Proxy Statement for our 2009 Annual Meeting of Stockholders to be held on May 13, 2009 is incorporated herein by reference.

PART IV

Item 15. EXHIBITS AND FINANCIAL STATEMENT SCHEDULES.

(a)(1) Financial Statements

The following financial statements are included in a separate section of this Report commencing on the page numbers specified below:

Report of Independent Registered Public Accounting Firm	59
Consolidated Statements of Operations for the years ended December 31, 2008, 2007 and 2006	60
Consolidated Balance Sheets as of December 31, 2008 and 2007	61
Consolidated Statements of Stockholders' Equity for the years ended December 31, 2008, 2007 and 2006	62
Consolidated Statements of Cash Flows for the years ended December 31, 2008, 2007 and 2006	63
Notes to Consolidated Financial Statements	64-102

(a)(2) Schedules

Schedule II—Valuation and Qualifying Accounts for the years ended December 31, 2008, 2007 and 2006	103
---	-----

All other required schedules for which provision is made in the applicable accounting regulations of the Securities and Exchange Commission are included in the Notes to the Consolidated Financial Statements.

(a)(3) Exhibits

The exhibits listed in the Exhibit Index immediately preceding the exhibits are filed as part of this Annual Report on Form 10-K.

SIGNATURES

Pursuant to the requirements of Section 13 or 15(d) of the Securities Exchange Act of 1934, the registrant has duly caused this report to be signed on its behalf by the undersigned, thereunto duly authorized.

WATTS WATER TECHNOLOGIES, INC.

By: /s/ PATRICK S. O'KEEFE
Patrick S. O'Keefe
Chief Executive Officer
President and Director

DATED: February 27, 2009

Pursuant to the requirements of the Securities Exchange Act of 1934, this report has been signed below by the following persons on behalf of the registrant and in the capacities and on the dates indicated.

<u>Signature</u>	<u>Title</u>	<u>Date</u>
<u> /s/ PATRICK S. O'KEEFE </u> Patrick S. O'Keefe	Chief Executive Officer, President and Director	February 27, 2009
<u> /s/ WILLIAM C. MCCARTNEY </u> William C. McCartney	Chief Financial Officer and Treasurer (Principal Financial and Accounting Officer)	February 27, 2009
<u> /s/ ROBERT L. AYERS </u> Robert L. Ayers	Director	February 27, 2009
<u> /s/ KENNETT F. BURNES </u> Kennett F. Burnes	Director	February 27, 2009
<u> /s/ RICHARD J. CATHCART </u> Richard J. Cathcart	Director	February 27, 2009
<u> /s/ TIMOTHY P. HORNE </u> Timothy P. Horne	Director	February 27, 2009
<u> /s/ RALPH E. JACKSON, JR. </u> Ralph E. Jackson, Jr.	Director	February 27, 2009

<u>Signature</u>	<u>Title</u>	<u>Date</u>
<u>/s/ KENNETH J. MCAVOY</u> Kenneth J. McAvoy	Director	February 27, 2009
<u>/s/ JOHN K. MCGILlicuddy</u> John K. McGillicuddy	Director	February 27, 2009
<u>/s/ GORDON W. MORAN</u> Gordon W. Moran	Chairman of the Board	February 27, 2009
<u>/s/ DANIEL J. MURPHY, III</u> Daniel J. Murphy, III	Director	February 27, 2009

Report of Independent Registered Public Accounting Firm

The Board of Directors and Stockholders
Watts Water Technologies, Inc.:

We have audited the accompanying consolidated balance sheets of Watts Water Technologies, Inc. and subsidiaries as of December 31, 2008 and 2007, and the related consolidated statements of operations, stockholders' equity, and cash flows for each of the years in the three-year period ended December 31, 2008. In connection with our audits of the consolidated financial statements, we have also audited the financial statement schedule. These consolidated financial statements and financial statement schedule are the responsibility of the Company's management. Our responsibility is to express an opinion on these consolidated financial statements and financial statement schedule based on our audits.

We conducted our audits in accordance with the standards of the Public Company Accounting Oversight Board (United States). Those standards require that we plan and perform the audit to obtain reasonable assurance about whether the financial statements are free of material misstatement. An audit includes examining, on a test basis, evidence supporting the amounts and disclosures in the financial statements. An audit also includes assessing the accounting principles used and significant estimates made by management, as well as evaluating the overall financial statement presentation. We believe that our audits provide a reasonable basis for our opinion.

In our opinion, the consolidated financial statements referred to above present fairly, in all material respects, the financial position of Watts Water Technologies, Inc. and subsidiaries as of December 31, 2008 and 2007, and the results of their operations and their cash flows for each of the years in the three-year period ended December 31, 2008, in conformity with U.S. generally accepted accounting principles. Also, in our opinion, the financial statement schedule, when considered in relation to the basic consolidated financial statements taken as a whole, presents fairly, in all material respects, the information set forth therein.

As discussed in Note 2 to the consolidated financial statements, the Company adopted the recognition and disclosure provisions of Statement of Financial Accounting Standards No. 158, *Employers' Accounting for Defined Benefit Pension and Other Postretirement Plans—an amendment of FASB Statements No. 87, 88, 106, and 132(R)* effective December 31, 2006 and its measurement date provisions on January 1, 2007.

Also, as discussed in Note 2 to the consolidated financial statements, the Company adopted FASB Interpretation No. 48, *Accounting for Uncertainty in Income Taxes—an interpretation of FASB Statement No. 109* effective January 1, 2007.

We also have audited, in accordance with the standards of the Public Company Accounting Oversight Board (United States), Watts Water Technologies, Inc.'s internal control over financial reporting as of December 31, 2008, based on criteria established in *Internal Control—Integrated Framework* issued by the Committee of Sponsoring Organizations of the Treadway Commission (COSO), and our report dated February 27, 2009 expressed an unqualified opinion on the effectiveness of the Company's internal control over financial reporting.

KPMG LLP

Boston, Massachusetts
February 27, 2009

Watts Water Technologies, Inc. and Subsidiaries
Consolidated Statements of Operations
(Amounts in millions, except per share information)

	Years Ended December 31,		
	2008	2007	2006
Net sales	\$1,459.4	\$1,382.3	\$1,230.8
Cost of goods sold	971.0	920.7	805.8
GROSS PROFIT	488.4	461.6	425.0
Selling, general and administrative expenses	360.2	332.7	300.2
Restructuring and other (income) charges	5.6	3.2	(5.7)
Goodwill impairment charge	22.0	—	—
OPERATING INCOME	100.6	125.7	130.5
Other (income) expense:			
Interest income	(5.1)	(14.5)	(5.0)
Interest expense	26.2	26.9	22.1
Minority interest	(1.9)	(2.8)	(1.8)
Other	9.1	2.3	(.9)
	<u>28.3</u>	<u>11.9</u>	<u>14.4</u>
INCOME FROM CONTINUING OPERATIONS BEFORE INCOME TAXES	72.3	113.8	116.1
Provision for income taxes	25.0	36.2	39.0
INCOME FROM CONTINUING OPERATIONS	47.3	77.6	77.1
Loss from discontinued operations, net of taxes of \$0.4 in 2008, \$0.2 in 2007 and \$2.1 in 2006	(0.7)	(0.2)	(3.4)
NET INCOME	\$ 46.6	\$ 77.4	\$ 73.7
Basic EPS			
Income (loss) per share:			
Continuing operations	\$ 1.29	\$ 2.01	\$ 2.32
Discontinued operations	(0.02)	(0.01)	(0.10)
NET INCOME	\$ 1.27	\$ 2.00	\$ 2.21
Weighted average number of shares	<u>36.6</u>	<u>38.6</u>	<u>33.3</u>
Diluted EPS			
Income (loss) per share:			
Continuing operations	\$ 1.28	\$ 1.99	\$ 2.29
Discontinued operations	(0.02)	(0.01)	(0.10)
NET INCOME	\$ 1.26	\$ 1.99	\$ 2.19
Weighted average number of shares	<u>36.8</u>	<u>39.0</u>	<u>33.7</u>
Dividends per share	<u>\$ 0.44</u>	<u>\$ 0.40</u>	<u>\$ 0.36</u>

The accompanying notes are an integral part of these consolidated financial statements.

Watts Water Technologies, Inc. and Subsidiaries
Consolidated Balance Sheets
(Amounts in millions, except share information)

	December 31,	
	2008	2007
ASSETS		
CURRENT ASSETS:		
Cash and cash equivalents	\$ 165.6	\$ 290.3
Short-term investment securities	—	22.0
Trade accounts receivable, less allowance for doubtful accounts of \$12.2 million in 2008 and \$14.9 million in 2007	221.3	235.7
Inventories, net	339.0	341.6
Prepaid expenses and other assets	14.6	18.6
Deferred income taxes	47.5	38.1
Assets of discontinued operations	11.6	10.4
Total Current Assets	799.6	956.7
PROPERTY, PLANT AND EQUIPMENT, NET	237.4	223.7
OTHER ASSETS:		
Goodwill	431.3	385.8
Long-term investment securities	8.3	17.0
Intangible assets, net	174.6	134.0
Other, net	8.9	12.1
TOTAL ASSETS	\$1,660.1	\$1,729.3
LIABILITIES AND STOCKHOLDERS' EQUITY		
CURRENT LIABILITIES:		
Accounts payable	\$ 115.2	\$ 108.0
Accrued expenses and other liabilities	103.9	113.6
Accrued compensation and benefits	41.6	38.2
Current portion of long-term debt	4.5	1.3
Liabilities of discontinued operations	29.7	28.6
Total Current Liabilities	294.9	289.7
LONG-TERM DEBT, NET OF CURRENT PORTION	409.8	432.2
DEFERRED INCOME TAXES	42.4	42.9
OTHER NONCURRENT LIABILITIES	70.6	45.6
MINORITY INTEREST	—	3.4
STOCKHOLDERS' EQUITY:		
Preferred Stock, \$0.10 par value; 5,000,000 shares authorized; no shares issued or outstanding	—	—
Class A Common Stock, \$0.10 par value; 80,000,000 shares authorized; 1 vote per share; issued and outstanding, 29,250,175 shares in 2008 and 30,600,056 shares in 2007	2.9	3.1
Class B Common Stock, \$0.10 par value; 25,000,000 shares authorized; 10 votes per share; issued and outstanding, 7,293,880 shares in 2008 and in 2007	0.7	0.7
Additional paid-in capital	386.9	377.6
Retained earnings	451.7	465.4
Accumulated other comprehensive income	0.2	68.7
Total Stockholders' Equity	842.4	915.5
TOTAL LIABILITIES AND STOCKHOLDERS' EQUITY	\$1,660.1	\$1,729.3

The accompanying notes are an integral part of these consolidated financial statements.

Watts Water Technologies, Inc. and Subsidiaries
Consolidated Statements of Stockholders' Equity
(Amounts in millions, except share information)

	Class A Common Stock		Class B Common Stock		Additional Paid-In Capital	Retained Earnings	Accumulated Other Comprehensive Income (Loss)	Total Stockholders' Equity
	Shares	Amount	Shares	Amount				
Balance at December 31, 2005	25,205,210	\$ 2.5	7,343,880	\$.7	\$142.7	\$368.3	\$ 5.3	\$519.5
Comprehensive income:								
Net income						73.7		73.7
Cumulative translation adjustment and other							25.0	25.0
Pension plan additional liability, net of tax of \$0.6 million							0.9	0.9
Comprehensive income								99.6
Initial impact upon adoption of FAS 158, net of tax of (\$3.8m)							(5.8)	(5.8)
Shares of Class A Common Stock issued upon the exercise of stock options	106,499	—			1.9			1.9
Tax benefit for stock options exercised					1.4			1.4
Stock-based compensation					3.0			3.0
Shares of Class B Common Stock converted to Class A Common Stock	50,000	—	(50,000)	—				—
Issuance of shares of restricted Class A Common Stock	59,008	—			—			—
Net change in restricted stock units	68,394	—			0.8			0.8
Shares of Class A Common Stock issued in Stock Offering, net of offering costs of \$11.4 million	5,750,000	0.6			218.0			218.6
Common Stock dividends						(12.4)		(12.4)
Balance at December 31, 2006	31,239,111	\$ 3.1	7,293,880	\$0.7	\$367.8	\$429.6	\$ 25.4	\$826.6
Comprehensive income:								
Net income						77.4		77.4
Cumulative translation adjustment and other							39.1	39.1
Pension plan gain arising during the year, net of tax of \$3.0 million							4.2	4.2
Comprehensive income								120.7
Impact upon adoption of measurement date provisions of FAS158							(0.8)	(0.8)
Shares of Class A Common Stock issued upon the exercise of stock options	66,658	—			1.1			1.1
Tax benefit for stock awards exercised					1.0			1.0
Stock-based compensation					6.0			6.0
Issuance of shares of restricted Class A Common Stock	58,726	—			—			—
Net change in restricted stock units	109,977	—			1.7			1.7
Repurchase and retirement of Class A Common Stock	(874,416)	—					(25.2)	(25.2)
Common Stock dividends						(15.6)		(15.6)
Balance at December 31, 2007	30,600,056	\$ 3.1	7,293,880	\$0.7	\$377.6	\$465.4	\$ 68.7	\$915.5
Comprehensive income:								
Net income						46.6		46.6
Cumulative translation adjustment and other							(51.8)	(51.8)
Pension plan loss arising during the year, net of tax of \$9.7 million							(16.7)	(16.7)
Comprehensive loss								(21.9)
Shares of Class A Common Stock issued upon the exercise of stock options	85,512				1.6			1.6
Stock-based compensation					5.3			5.3
Issuance of shares of restricted Class A Common Stock	73,542							
Net change in restricted stock units	109,689				2.4			2.4
Repurchase and retirement of Class A Common Stock	(1,618,624)	(0.2)					(44.1)	(44.3)
Common Stock dividends						(16.2)		(16.2)
Balance at December 31, 2008	29,250,175	\$ 2.9	7,293,880	\$0.7	\$386.9	\$451.7	\$ 0.2	\$842.4

The accompanying notes are an integral part of these consolidated financial statements.

Watts Water Technologies, Inc. and Subsidiaries
Consolidated Statements of Cash Flows
(Amounts in millions)

	<u>Years Ended December 31,</u>		
	<u>2008</u>	<u>2007</u>	<u>2006</u>
OPERATING ACTIVITIES			
Net income	\$ 46.6	\$ 77.4	73.7
Less: loss from discontinued operations	(0.7)	(0.2)	(3.4)
Income from continuing operations	47.3	77.6	77.1
Adjustments to reconcile income from continuing operations to net cash provided by continuing operating activities:			
Depreciation	31.8	28.9	26.7
Amortization	13.3	10.5	8.6
(Gain) loss on disposal and impairment of goodwill, property, plant and equipment and other	24.0	2.0	(8.3)
Stock-based compensation	5.3	6.0	3.0
Deferred income tax benefit	(18.7)	(8.2)	(2.1)
Changes in operating assets and liabilities, net of effects from business acquisitions and divestitures:			
Accounts receivable	24.8	6.5	(17.0)
Inventories	14.1	(8.1)	(37.3)
Prepaid expenses and other assets	8.3	(1.2)	2.0
Accounts payable, accrued expenses and other liabilities	(3.8)	(22.3)	30.3
Net cash provided by continuing operations	<u>146.4</u>	<u>91.7</u>	<u>83.0</u>
INVESTING ACTIVITIES			
Additions to property, plant and equipment	(26.6)	(37.8)	(44.7)
Proceeds from the sale of property, plant and equipment	1.1	0.6	31.9
Investments in securities	(2.7)	(27.5)	(11.8)
Proceeds from sale of securities	33.3	0.4	—
Increase in other assets	—	(0.5)	(1.2)
Business acquisitions, net of cash acquired	(177.3)	(22.6)	(93.4)
Net cash used in investing activities	<u>(172.2)</u>	<u>(87.4)</u>	<u>(119.2)</u>
FINANCING ACTIVITIES			
Proceeds from long-term debt	22.9	43.8	356.6
Payments of long-term debt	(54.9)	(71.5)	(228.3)
Payment of capital leases	(1.3)	(1.7)	(4.1)
Proceeds from share transactions under employee stock plans	1.6	1.1	1.9
Tax benefit of stock awards exercised	—	1.0	1.4
Debt issue costs	—	—	(2.4)
Proceeds from stock offering, net	—	—	218.6
Payments to repurchase common stock	(44.5)	(23.6)	—
Dividends	(16.2)	(15.6)	(12.4)
Net cash provided by (used in) financing activities	<u>(92.4)</u>	<u>(66.5)</u>	<u>331.3</u>
Effect of exchange rate changes on cash and cash equivalents	(5.9)	9.4	1.2
Net cash provided by (used in) operating activities of discontinued operations	(0.6)	0.1	0.9
INCREASE (DECREASE) IN CASH AND CASH EQUIVALENTS	(124.7)	(52.7)	297.2
Cash and cash equivalents at beginning of year	290.3	343.0	45.8
CASH AND CASH EQUIVALENTS AT END OF YEAR	<u>\$ 165.6</u>	<u>\$290.3</u>	<u>\$343.0</u>
NON CASH INVESTING AND FINANCING ACTIVITIES			
Acquisition of businesses:			
Fair value of assets acquired	\$ 231.5	\$ 23.7	\$161.5
Cash paid, net of cash acquired	176.8	22.7	93.4
Liabilities assumed	<u>\$ 54.7</u>	<u>\$ 1.0</u>	<u>\$ 68.1</u>
Acquisitions of property, plant and equipment under capital lease	—	\$ 1.4	\$ 16.0
Issuance of stock under management stock purchase plan	<u>\$ 1.6</u>	<u>\$ 1.7</u>	<u>\$ 0.8</u>
Liability for shares repurchased	<u>\$ —</u>	<u>\$ 1.4</u>	<u>\$ —</u>
Retirement of variable rate demand bonds with cash collateral	<u>\$ —</u>	<u>\$ —</u>	<u>\$ (8.9)</u>
CASH PAID FOR:			
Interest	<u>\$ 26.9</u>	<u>\$ 27.1</u>	<u>\$ 21.7</u>
Taxes	<u>\$ 45.1</u>	<u>\$ 48.0</u>	<u>\$ 35.3</u>

The accompanying notes are an integral part of these consolidated financial statements.

Watts Water Technologies, Inc. and Subsidiaries
Notes to Consolidated Financial Statements

(1) Description of Business

Watts Water Technologies, Inc. (the Company) designs, manufactures and sells an extensive line of water safety and flow control products primarily for the water quality, water conservation, water safety and water flow control markets located predominantly in North America, Europe, and China.

(2) Accounting Policies

Principles of Consolidation

The consolidated financial statements include the accounts of the Company and its majority and wholly owned subsidiaries. Upon consolidation, all significant intercompany accounts and transactions are eliminated.

Cash Equivalents

Cash equivalents consist of highly liquid investments with maturities of three months or less at the date of original issuance.

Investment Securities

Investment securities at December 31, 2008 and 2007 consisted of auction rate securities (ARS) whose underlying investments were in municipal bonds and student loans and, in 2008, investments in rights issued by UBS. The securities were purchased at par value. The rights issued by UBS were received in connection with a settlement agreement. See Note 16 for additional information regarding the rights issued by UBS. At December 31, 2008, the Company classified its debt securities and investment in rights from UBS as trading securities.

Trading securities are recorded at fair value. The Company determines the fair value by obtaining market value when available from quoted prices in active markets. In the absence of quoted prices, the Company uses other inputs to determine the fair value of the investments. All changes in the fair value as well as any realized gains and losses from the sale of the securities are recorded when incurred to the Consolidated Statements of Operations as other income or expense.

At December 31, 2007, the Company had classified the ARS as available-for-sale and recorded the ARS at fair value.

Allowance for Doubtful Accounts

Allowance for doubtful accounts includes reserves for bad debts and sales returns and allowances. The Company analyzes the aging of accounts receivable, individual accounts receivable, historical bad debts, concentration of receivables by customer, customer credit worthiness, current economic trends and changes in customer payment terms. The Company specifically analyzes individual accounts receivable and establishes specific reserves against financially troubled customers. In addition, factors are developed in certain regions utilizing historical trends of sales and returns and allowances to derive a reserve for returns and allowances.

Concentration of Credit

The Company sells products to a diversified customer base and, therefore, has no significant concentrations of credit risk, except that approximately 10.0% of the Company's total sales in 2006 were to one customer. These sales were transacted within the North America geographic segment. In 2008 and 2007, no one customer accounted for 10.0% or more of the Company's total sales.

Watts Water Technologies, Inc. and Subsidiaries
Notes to Consolidated Financial Statements (Continued)

(2) Accounting Policies (Continued)

Inventories

Inventories are stated at the lower of cost (using primarily the first-in, first-out method) or market. Market value is determined by replacement cost or net realizable value. Historical experience is used as the basis for determining the reserve for excess or obsolete inventories.

Goodwill and Other Intangible Assets

Goodwill is recorded when the consideration paid for acquisitions exceeds the fair value of net tangible and intangible assets acquired. Goodwill and other intangible assets with indefinite useful lives are not amortized, but rather are tested annually for impairment. The test was performed as of October 26, 2008.

Impairment of Goodwill and Long-Lived Assets

Goodwill and intangible assets with indefinite lives are tested annually for impairment in accordance with the provisions of Financial Accounting Standards Board Statement No. 142 "Goodwill and Other Intangible Assets" (FAS 142). The Company's impairment review is based on a discounted cash flow approach at the reporting unit level that requires management judgment with respect to revenue and expense growth rates, changes in working capital and the selection and use of an appropriate discount rate. The Company uses its judgment in assessing whether assets may have become impaired between annual impairment tests. Indicators such as unexpected adverse business conditions, economic factors, unanticipated technological change or competitive activities, loss of key personnel and acts by governments and courts, may signal that an asset has become impaired.

Intangible assets with estimable lives and other long-lived assets are reviewed for impairment whenever events or changes in circumstances indicate that the carrying amount of an asset or asset group may not be recoverable in accordance with Financial Accounting Standards Board Statement No. 144, "Accounting for the Impairment or Disposal of Long-Lived Assets" (FAS 144). Recoverability of intangible assets with estimable lives and other long-lived assets is measured by a comparison of the carrying amount of an asset or asset group to future net undiscounted pretax cash flows expected to be generated by the asset or asset group. If these comparisons indicate that an asset is not recoverable, the impairment loss recognized is the amount by which the carrying amount of the asset or asset group exceeds the related estimated fair value. Estimated fair value is based on either discounted future pretax operating cash flows or appraised values, depending on the nature of the asset. The Company determines the discount rate for this analysis based on the expected internal rate of return for the related business and does not allocate interest charges to the asset or asset group being measured. Judgment is required to estimate future operating cash flows.

As a result of the recent economic downturn and other business developments, goodwill in the Company's Water Quality reporting unit was impaired during the fourth quarter of 2008. The Water Quality reporting unit includes a number of businesses that were purchased over time. Most recently, the Company acquired substantially all the assets of Topway Global Inc. (Topway) in November 2007. With the recent decline in commercial and residential projects and threatened legislation in the state of California against water softeners, a principal market for Topway, sales declined from prior year levels and from the Company's expectations. Although the Company continues to see positive results from other businesses within the Water Quality reporting unit, the decline in sales in the fourth quarter of 2008 coupled with the current economic outlook negatively impacted the expected cash flows of the reporting unit. The Company completed an assessment of the fair value of the net assets of the

Watts Water Technologies, Inc. and Subsidiaries
Notes to Consolidated Financial Statements (Continued)

(2) Accounting Policies (Continued)

reporting unit and recorded a pre-tax impairment of \$22.0 million in the fourth quarter of 2008. The Company estimated the fair value of the reporting unit using the expected present value of future cash flows.

The changes in the carrying amount of goodwill are as follows:

	<u>North America</u>	<u>Europe</u>	<u>China</u>	<u>Total</u>
	(in millions)			
Carrying amount at December 31, 2006	\$198.9	\$147.9	\$ 9.3	\$356.1
Goodwill acquired during the period	7.6	—	—	7.6
Adjustments to goodwill during the period	3.8	1.1	2.4	7.3
Effect of change in exchange rates used for translation	0.7	13.4	0.7	14.8
Carrying amount at December 31, 2007	\$211.0	\$162.4	\$12.4	\$385.8
Goodwill acquired during the period	—	89.5	3.3	92.8
Adjustments to goodwill during the period	0.4	—	(2.6)	(2.2)
Goodwill impairment charge	(22.0)	—	—	(22.0)
Effect of change in exchange rates used for translation	(1.1)	(22.9)	0.9	(23.1)
Carrying amount at December 31, 2008	\$188.3	\$229.0	\$14.0	\$431.3

The adjustments to North American goodwill during the year ended December 31, 2008 relate to approximately \$0.4 million for an earn-out provision. The adjustment to China goodwill during the year ended December 31, 2008 includes the write-off of goodwill relating to the disposition of Tianjin Tanggu Watts Valve Company, Ltd. (TWT) and the finalization of the Changsha Valve Works purchase price allocation.

The adjustments to North American goodwill during the year ended December 31, 2007 relate to an accrual of approximately \$3.8 million in earn-out provisions. The adjustment to European goodwill during the year ended December 31, 2007 includes the finalization of the ATS Expansion Group purchase price allocation. ATS Expansion Group was acquired in May 2006. The adjustment to China goodwill during the year ended December 31, 2007 includes the finalization of the Changsha Valve Works purchase price allocation. Changsha Valve Works was acquired in April 2006.

Intangible assets include the following:

	December 31,			
	2008		2007	
	<u>Gross Carrying Amount</u>	<u>Accumulated Amortization</u>	<u>Gross Carrying Amount</u>	<u>Accumulated Amortization</u>
	(in millions)			
Patents	\$ 18.0	\$ (7.3)	\$ 13.8	\$ (6.1)
Customer relationships	109.7	(24.6)	70.0	(14.3)
Technology	7.5	(3.3)	7.5	(2.3)
Other	19.1	(6.5)	19.0	(5.8)
Total amortizable intangible assets	<u>154.3</u>	<u>(41.7)</u>	<u>110.3</u>	<u>(28.5)</u>
Intangible assets not subject to amortization	<u>62.0</u>	<u>—</u>	<u>52.2</u>	<u>—</u>
Total	<u>\$216.3</u>	<u>\$(41.7)</u>	<u>\$162.5</u>	<u>\$(28.5)</u>

Watts Water Technologies, Inc. and Subsidiaries
Notes to Consolidated Financial Statements (Continued)

(2) Accounting Policies (Continued)

Aggregate amortization expense for amortized intangible assets for the years ended December 31, 2008, 2007 and 2006 was \$13.3 million, \$10.5 million and \$8.6 million, respectively. Additionally, future amortization expense on amortizable intangible assets approximates \$14.4 million for 2009, \$14.2 million for 2010, \$14.0 million for 2011, \$12.5 million for 2012 and \$11.3 million for 2013. Amortization expense is provided on a straight-line basis over the estimated useful lives of the intangible assets. The weighted-average remaining life of total amortizable intangible assets is 10.8 years. Patents, customer relationships, technology and other amortizable intangibles have weighted-average remaining lives of 8.2 years, 10.2 years, 5.2 years and 19.1 years, respectively. Intangible assets not subject to amortization primarily include trademarks and unpatented technology.

Property, Plant and Equipment

Property, plant and equipment are recorded at cost. Depreciation is provided on a straight-line basis over the estimated useful lives of the assets, which range from 10 to 40 years for buildings and improvements and 3 to 15 years for machinery and equipment.

Taxes, Other than Income Taxes

Taxes assessed by governmental authorities on sale transactions are recorded on a net basis and excluded from sales, in the Company's consolidated statements of operations.

Income Taxes

Income taxes are accounted for under the asset and liability method. Deferred tax assets and liabilities are recognized for the future tax consequences attributable to differences between the financial statement carrying amounts of existing assets and liabilities and their respective tax bases and operating loss and tax credit carry forwards. Deferred tax assets and liabilities are measured using enacted tax rates expected to apply to taxable income in the years in which those temporary differences are expected to be recovered or settled. The effect on deferred tax assets and liabilities of a change in tax rates is recognized in income in the period that includes the enactment date.

On January 1, 2007, the Company adopted the provisions of Financial Interpretation No. 48, "Accounting for Uncertainty in Income Taxes" (FIN 48). The purpose of FIN 48 is to increase the comparability in financial reporting of income taxes. FIN 48 requires that in order for a tax benefit to be booked in the income statement, the item in question must meet the more-likely-than-not (greater than 50% likelihood of being sustained upon examination by the taxing authorities) threshold. The adoption of FIN 48 did not have a material effect on the Company's financial statements. No cumulative effect was booked through beginning retained earnings.

During 2008, the Company reduced its unrecognized tax benefits by approximately \$2.2 million as a result of finalizing federal and state income tax audits. The Company estimates that it is reasonably possible that a portion of the currently remaining unrecognized tax benefit may be recognized by the end of 2009 as a result of the conclusion of the federal income tax audit. The amount of expense accrued for penalties and interest is \$1.1 million worldwide.

As of December 31, 2008, the Company had gross unrecognized tax benefits of approximately \$2.3 million of which, approximately \$1.9 million, if recognized, would affect the effective tax rate. The difference between the amount of unrecognized tax benefits and the amount that would impact the effective tax rate consists of the federal tax benefit of state income tax items. A reconciliation of the

Watts Water Technologies, Inc. and Subsidiaries
Notes to Consolidated Financial Statements (Continued)

(2) Accounting Policies (Continued)

beginning and ending amount of unrecognized tax benefits and a separate analysis of accrued interest related to the unrecognized tax benefits is as follows:

	<u>(in millions)</u>
Balance at January 1, 2008	\$ 3.7
Increases related to prior year tax positions	0.9
Decreases related to prior year tax positions	(1.6)
Increases related to current year tax positions	—
Decreases related to statute expirations	(0.1)
Settlements	<u>(0.6)</u>
Balance at December 31, 2008	<u>\$ 2.3</u>

The Company is currently under audit by the Internal Revenue Service for the 2005 and 2006 tax years. The expected completion date for this audit is November 2009. The Company does not anticipate any significant adjustments at this time. Watts conducts business in a variety of locations throughout the world resulting in tax filings in numerous domestic and foreign jurisdictions. The Company is subject to tax examinations regularly as part of the normal course of business. The Company's major jurisdictions are the U.S., Canada, China, Netherlands, U.K., Germany, Italy and France. With few exceptions the Company is no longer subject to U.S. federal, state and local, or non-U.S. income tax examinations for years before 2003.

The Company accounts for interest and penalties related to uncertain tax positions as a component of income tax expense.

The statute of limitations in our major jurisdictions is open in the U.S. for the year 2005 and later; in Canada for 2004 and later; and in the Netherlands for 2004 and later.

Foreign Currency Translation

The financial statements of subsidiaries located outside the United States generally are measured using the local currency as the functional currency. Balance sheet accounts, including goodwill, of foreign subsidiaries are translated into United States dollars at year-end exchange rates. Income and expense items are translated at weighted average exchange rates for each period. Net translation gains or losses are included in other comprehensive income, a separate component of stockholders' equity. The Company does not provide for U.S. income taxes on foreign currency translation adjustments since it does not provide for such taxes on undistributed earnings of foreign subsidiaries. Gains and losses from foreign currency transactions of these subsidiaries are included in net earnings.

Stock-Based Compensation

Effective January 1, 2006, the Company adopted Financial Accounting Standards Board Statement No. 123R, "Share-Based Payment" (FAS 123R) utilizing the "modified prospective" method as described in FAS 123R. Under the "modified prospective" method, compensation cost is recognized for all share-based payments granted after the effective date and for all unvested awards granted prior to the effective date. In accordance with FAS 123R, prior period amounts were not restated. FAS 123R also requires the excess tax benefits associated with these share-based payments to be classified as financing activities in the Statements of Consolidated Cash Flows, rather than as operating cash flows as required under previous regulations.

Watts Water Technologies, Inc. and Subsidiaries
Notes to Consolidated Financial Statements (Continued)

(2) Accounting Policies (Continued)

At December 31, 2008, the Company had three stock-based compensation plans with total unrecognized compensation costs related to unvested stock-based compensation arrangements of approximately \$7.6 million and a total weighted average remaining term of 2.1 years. For 2008, 2007 and 2006 the Company recognized compensation costs related to stock-based programs of approximately \$5.3 million, \$6.0 million and \$3.0 million respectively, in selling, general and administrative expenses. The Company recorded approximately \$0.7 million, \$0.7 million and \$0.4 million of tax benefit during 2008, 2007 and 2006, respectively, for the compensation expense relating to its stock options. For 2008, 2007 and 2006, the Company recorded approximately \$1.1 million, \$1.3 million and \$0.6 million respectively, of tax benefit for its other stock-based plans. For 2008, 2007 and 2006, the recognition of total stock-based compensation expense impacted both basic and diluted net income per common share by \$0.10, \$0.10 and \$0.06, respectively.

Net Income Per Common Share

Basic net income per common share is calculated by dividing net income by the weighted average number of common shares outstanding. The calculation of diluted income per share assumes the conversion of all dilutive securities (see Note 13).

Net income and number of shares used to compute net income per share, basic and assuming full dilution, are reconciled below:

	Years Ended December 31,								
	2008			2007			2006		
	Net Income	Shares	Per Share Amount	Net Income	Shares	Per Share Amount	Net Income	Shares	Per Share Amount
	(Amounts in millions, except per share information)								
Basic EPS	\$46.6	36.6	\$ 1.27	\$77.4	38.6	\$ 2.00	\$73.7	33.3	\$ 2.21
Dilutive securities principally common stock options	—	0.2	(0.1)	—	0.4	(0.01)	—	0.4	(0.02)
Diluted EPS	<u>\$46.6</u>	<u>36.8</u>	<u>\$ 1.26</u>	<u>\$77.4</u>	<u>39.0</u>	<u>\$ 1.99</u>	<u>\$73.7</u>	<u>33.7</u>	<u>\$ 2.19</u>

The computation of diluted net income per share for the years ended December 31, 2008 and 2007 excludes the effect of the potential exercise of options to purchase approximately 1.0 million and 0.5 million shares, respectively, because the exercise price of the option was greater than the average market price of the Class A Common Stock, as the effect would have been anti-dilutive.

During the year ended December 31, 2008, the Company repurchased approximately 1.6 million shares of its Class A Common Stock.

Derivative Financial Instruments

In the normal course of business, the Company manages risks associated with commodity prices, foreign exchange rates and interest rates through a variety of strategies, including the use of hedging transactions, executed in accordance with the Company's policies. The Company's hedging transactions include, but are not limited to, the use of various derivative financial and commodity instruments. As a matter of policy, the Company does not use derivative instruments unless there is an underlying exposure. Any change in value of the derivative instruments would be substantially offset by an

Watts Water Technologies, Inc. and Subsidiaries
Notes to Consolidated Financial Statements (Continued)

(2) Accounting Policies (Continued)

opposite change in the value of the underlying hedged items. The Company does not use derivative instruments for trading or speculative purposes.

Using qualifying criteria defined in Financial Accounting Standards Board Statement No. 133, "Accounting for Derivative Instruments and Hedging Activities" (FAS 133), derivative instruments are designated and accounted for as either a hedge of a recognized asset or liability (fair value hedge) or a hedge of a forecasted transaction (cash flow hedge). For a fair value hedge, both the effective and ineffective portions of the change in fair value of the derivative instrument, along with an adjustment to the carrying amount of the hedged item for fair value changes attributable to the hedged risk, are recognized in earnings. For a cash flow hedge, changes in the fair value of the derivative instrument that are highly effective are deferred in accumulated other comprehensive income or loss until the underlying hedged item is recognized in earnings.

If a fair value or cash flow hedge were to cease to qualify for hedge accounting or be terminated, it would continue to be carried on the balance sheet at fair value until settled, but hedge accounting would be discontinued prospectively. If a forecasted transaction was no longer probable of occurring, amounts previously deferred in accumulated other comprehensive income would be recognized immediately in earnings. On occasion, the Company may enter into a derivative instrument that does not qualify for hedge accounting because it is entered into to offset changes in the fair value of an underlying transaction which is required to be recognized in earnings (natural hedge). These instruments are reflected in the Consolidated Balance Sheets at fair value with changes in fair value recognized in earnings.

Foreign currency derivatives include forward foreign exchange contracts primarily for Canadian dollars. Metal derivatives include commodity swaps for copper. During 2008, the Company used a copper swap as a means of hedging exposure to metal prices (see Note 16).

Portions of the Company's outstanding debt are exposed to interest rate risks. The Company monitors its interest rate exposures on an ongoing basis to maximize the overall effectiveness of its interest rates. During 2006, the Company used an interest rate swap as a means of hedging exposure to interest rate risks. The Company's interest rate swap did not qualify as a cash flow hedge under the criteria of FAS 133. The swap was terminated on October 3, 2006.

Shipping and Handling

Shipping and handling costs included in selling, general and administrative expense amounted to \$39.6 million, \$39.1 million and \$37.3 million for the years ended December 31, 2008, 2007 and 2006, respectively.

Research and Development

Research and development costs included in selling, general, and administrative expense amounted to \$17.5 million, \$15.1 million and \$12.7 million for the years ended December 31, 2008, 2007 and 2006, respectively.

Revenue Recognition

The Company recognizes revenue when all of the following criteria have been met: the Company has entered into a binding agreement, the product has been shipped and title passes, the sales price to the customer is fixed or is determinable, and collectability is reasonably assured. Provisions for

Watts Water Technologies, Inc. and Subsidiaries
Notes to Consolidated Financial Statements (Continued)

(2) Accounting Policies (Continued)

estimated returns and allowances are made at the time of sale, and are recorded as a reduction of sales and included in the allowance for doubtful accounts in the Consolidated Balance Sheets. The Company records provisions for sales incentives (primarily volume rebates), as an adjustment to net sales in accordance with the Financial Accounting Standards Board's Emerging Issues Task Force (EITF) Issue 00-14, "Accounting for Certain Sales Incentives" (EITF 00-14) and EITF Issue No 01-9, "Accounting for Consideration Given by a Vendor to a Customer or a Reseller of the Vendor's Products".

Estimates

The preparation of financial statements in conformity with accounting principles generally accepted in the United States requires management to make estimates and assumptions that affect the reported amounts of assets and liabilities and disclosure of contingent assets and liabilities at the date of the financial statements and the reported amounts of revenues and expenses during the reporting period. Actual results could differ from those estimates.

New Accounting Standards

In June 2008, the Financial Accounting Standards Board (FASB) issued FASB Staff Position (FSP) EITF Issue No. 03-6-1, "Determining Whether Instruments Granted in Share-Based Payment Transactions Are Participating Securities" (FSP EITF 03-6-1). FSP EITF 03-6-1 requires that unvested share-based payment awards that contain rights to receive non-forfeitable dividends or dividend equivalents to be included in the two-class method of computing earnings per share as described in Statement of Financial Accounting Standards (FAS) No. 128, "Earnings per Share." This FSP is effective for financial statements issued for fiscal years beginning after December 15, 2008, and interim periods within those years. Accordingly, we will adopt FSP EITF 03-6-1 in fiscal year 2009. The adoption of FSP EITF 03-6-1 is not expected to have a material impact on the consolidated financial statements.

In May 2008, the FASB issued FAS No. 162, "The Hierarchy of Generally Accepted Principles," (FAS 162), which identifies the sources of accounting principles and the framework for selecting the principles to be used in the preparation of financial statements of nongovernmental entities that are presented in conformity with generally accepted accounting principles (GAAP) in the United States (the GAAP hierarchy). FAS 162 is effective 60 days following the SEC's approval of the Public Company Accounting Oversight Board amendments to AU Section 411, "The Meaning of Present Fairly in Conformity With Generally Accepted Accounting Principles." The adoption of FAS 162 is not expected to have an impact on the Company's consolidated financial statements.

In April 2008, the FASB issued FSP No. FAS 142-3, "Determination of the Useful Life of Intangible Assets." This FSP amends the factors that should be considered in developing renewal or extension assumptions used to determine the useful life of a recognized intangible asset under FAS No. 142, "Goodwill and Other Intangible Assets" (FAS 142). The objective of this FSP is to improve the consistency between the useful life of a recognized intangible asset under FAS 142 and the period of expected cash flows used to measure the fair value of the asset under FAS 141(R), and other principles of GAAP. This FSP applies to all intangible assets, whether acquired in a business combination or otherwise, and shall be effective for financial statements issued for fiscal years beginning after December 15, 2008, and interim periods within those fiscal years and applied prospectively to intangible assets acquired after the effective date. Early adoption is prohibited. The

Watts Water Technologies, Inc. and Subsidiaries
Notes to Consolidated Financial Statements (Continued)

(2) Accounting Policies (Continued)

adoption of this FSP will not have a significant impact on the Company's consolidated financial statements.

In March 2008, the FASB issued FAS No. 161, "Disclosures about Derivative Instruments and Hedging Activities—an amendment of FASB Statement No. 133," (FAS 161), which expands the current disclosure requirements of FAS 133, "Accounting for Derivative Instruments and Hedging Activities," such that entities must now provide enhanced disclosures on a quarterly basis regarding how and why the entity uses derivatives; how derivatives and related hedged items are accounted for under FAS 133 and how derivatives and related hedged items affect the entity's financial position, performance and cash flow. FAS 161 is effective prospectively for annual and interim periods beginning on or after November 15, 2008. Accordingly, the Company will adopt FAS 161 in 2009.

In December 2007, the FASB issued FAS No. 141 (R), "Business Combinations," (FAS 141R), which requires most identifiable assets, liabilities, non-controlling interests, and goodwill acquired in a business combination to be recorded at "full fair value." Under FAS 141R, all business combinations will be accounted for under the acquisition method. Significant changes, among others, from current guidance resulting from FAS 141R includes the requirement that contingent assets and liabilities and contingent consideration shall be recorded at estimated fair value as of the acquisition date, with any subsequent changes in fair value charged or credited to earnings. Further, acquisition-related costs will be expensed rather than treated as part of the acquisition. FAS 141R is effective for periods beginning on or after December 15, 2008. The Company expects the adoption of FAS 141R will increase costs charged to its operations for acquisitions made after January 1, 2009.

In December 2007, the FASB issued FAS No. 160, "Non-controlling Interests in Consolidated Financial Statements, an amendment of ARB NO. 151," (FAS 160), which requires non-controlling interests (previously referred to as minority interest) to be treated as a separate component of equity, not outside of equity as is current practice. FAS 160 applies to non-controlling interests and transactions with non-controlling interest holders in consolidated financial statements. FAS 160 is effective for periods beginning on or after December 15, 2008. The Company does not expect the adoption of FAS 160 will have a material impact on its consolidated financial statements.

In February 2007, the FASB issued FAS No. 159, "The Fair Value Option for Financial Assets and Financial Liabilities—including an Amendment to FAS No. 115," (FAS 159), which permits entities to choose to measure many financial instruments and certain other items at fair value. FAS 159 is effective for financial statements issued for fiscal years beginning after November 15, 2007 and interim periods within those fiscal years. Earlier application is encouraged. The Company has elected not to measure its eligible financial instruments at fair value and therefore the adoption of FAS 159 did not have an impact on its consolidated financial statements.

In September 2006, the FASB issued FAS No. 157, "Fair Value Measurements," (FAS 157), which defines fair value, establishes guidelines for measuring fair value and expands disclosures regarding fair value measurements. FAS 157 does not require any new fair value measurements but rather eliminates inconsistencies in guidance found in various prior accounting pronouncements and was effective for fiscal years beginning after November 15, 2007. In February 2008, the FASB issued FASB FSP 157-2 which delayed the effective date of FAS 157 for all nonfinancial assets and nonfinancial liabilities, except those that are recognized or disclosed at fair value in the financial statements on a recurring basis (at least annually), until fiscal years beginning after November 15, 2008, and interim periods within those fiscal years. These nonfinancial items include assets and liabilities such as reporting units measured at fair value in a goodwill impairment test and nonfinancial assets acquired and liabilities

Watts Water Technologies, Inc. and Subsidiaries
Notes to Consolidated Financial Statements (Continued)

(2) Accounting Policies (Continued)

assumed in a business combination. Effective January 1, 2008, the Company adopted FAS 157 for financial assets and liabilities recognized at fair value on a recurring basis. The partial adoption of FAS 157 for financial assets and liabilities did not have a material impact on the Company's consolidated financial position, results of operations or cash flows.

In September 2006, the Securities and Exchange Commission issued Staff Accounting Bulletin No. 108, "Considering the Effects of Prior Year Misstatements When Quantifying Misstatements in Current Year Financial Statements" (SAB 108), which provides interpretive guidance on how the effects of the carryover or reversal of prior year misstatements should be considered in quantifying a current year misstatement. SAB 108 is effective for fiscal years ending after November 15, 2006. The Company adopted the provisions of SAB 108 for fiscal year 2006 and the impact of SAB 108 was not material to its consolidated financial statements.

In September 2006, the FASB issued FAS No. 158, "Employers' Accounting for Defined Benefit Pension and Other Postretirement Plans—an amendment of FASB Statements No. 87, 88, 106, and 132(R)," (FAS 158), which requires an employer to: (a) recognize in its statement of financial position an asset for a plan's overfunded status or a liability for a plan's underfunded status; (b) measure a plan's assets and its obligations that determine its funded status as of the end of the employer's fiscal year; and (c) recognize changes in the funded status of a defined benefit postretirement plan in the year in which the changes occur. Those changes are reported in other comprehensive income. The requirement to recognize the funded status of a benefit plan and the disclosure requirements are effective as of the end of the fiscal year ending after December 15, 2006 for companies with publicly traded equity securities. The requirement to measure plan assets and benefit obligations as of the date of the employer's fiscal year-end statement of financial position is effective for fiscal years ending after December 15, 2008, although earlier adoption is permitted. As a result of the requirement to recognize the funded status of the Company benefit plans as of December 31, 2006, the Company recorded an increase in its pension liability of approximately \$8.3 million, a decrease of approximately \$1.3 million in other assets: other, net and a decrease in accumulated other comprehensive income of approximately \$5.8 million, net of tax. The Company has early-adopted the measurement date provisions of FAS 158 effective January 1, 2007. The Company's pension plans previously used a September 30 measurement date. All plans are now measured as of December 31, consistent with the Company's fiscal year end. The non-cash effect of the adoption of the measurement date provisions of FAS 158 was not material and there was no effect on the Company's results of operations.

In July 2006, the FASB issued Financial Interpretation No. 48, "Accounting for Uncertainty in Income Taxes," (FIN 48), which clarifies the accounting for uncertainty in income taxes recognized in the financial statements in accordance with SFAS No. 109, "Accounting for Income Taxes." FIN 48 provides that a tax benefit from an uncertain tax position may be recognized when it is more likely than not that the position will be sustained upon examination, based on the technical merits. This interpretation also provides guidance on measurement, de-recognition, classification, interest and penalties, accounting in interim periods, disclosure and transition. FIN 48 was effective for fiscal years beginning after December 15, 2006. The Company adopted the provisions of FIN 48 for fiscal year 2007 and the impact was not material to its consolidated financial statements.

In March 2006, the FASB issued FAS No. 156 "Accounting for Servicing of Financial Assets—an amendment of FASB Statement No. 140," (FAS 156). FAS 156 amends FAS Statement No.140, "Accounting for Transfers and Servicing of Financial Assets and Extinguishments of Liabilities," with respect to the accounting for separately recognized servicing assets and servicing liabilities. FAS 156 addresses the recognition and measurement of separately recognized servicing assets and liabilities and

Watts Water Technologies, Inc. and Subsidiaries
Notes to Consolidated Financial Statements (Continued)

(2) Accounting Policies (Continued)

provides an approach to simplify efforts to obtain hedge-like (offset) accounting. The Company adopted the provisions of FAS 156 for fiscal year 2007 and the impact was not material to its consolidated financial statements.

In February 2006, the FASB issued FAS No. 155 “Accounting for Certain Hybrid Financial Instruments—an amendment of FASB Statements No. 133 and 140” (FAS 155). FAS 155 amends FAS 133, “Accounting for Derivatives and Hedging Activities,” and FAS 140, “Accounting for Transfers and Servicing of Financial Assets and Extinguishments of Liabilities,” and allows an entity to remeasure at fair value a hybrid financial instrument that contains an embedded derivative that otherwise would require bifurcation from the host, if the holder irrevocably elects to account for the whole instrument on a fair value basis. Subsequent changes in the fair value of the instrument would be recognized in earnings. The Company adopted the provisions of FAS 155 for fiscal year 2007 and the impact was not material to its consolidated financial statements.

(3) Discontinued Operations

In September 1996, the Company divested its Municipal Water Group businesses, which included Henry Pratt, James Jones Company and Edward Barber and Company Ltd. Costs and expenses related to the Municipal Water Group relate to legal and settlement costs associated with the James Jones Litigation (see Note 15).

Condensed operating statements and balance sheets for discontinued operations are summarized below:

	Years Ended December 31,		
	2008	2007	2006
	(in millions)		
Costs and expenses—Municipal Water Group	<u>\$(1.1)</u>	<u>\$(0.4)</u>	<u>\$(5.5)</u>
Loss before income taxes	<u>(1.1)</u>	<u>(0.4)</u>	<u>(5.5)</u>
Income tax benefit	<u>0.4</u>	<u>0.2</u>	<u>2.1</u>
Loss from discontinued operations, net of taxes	<u>\$(0.7)</u>	<u>\$(0.2)</u>	<u>\$(3.4)</u>
	December 31,		
	2008	2007	
	(in millions)		
Prepaid expenses and other assets	<u>\$ 0.8</u>	<u>\$(0.3)</u>	
Deferred income taxes	<u>10.8</u>	<u>10.7</u>	
Assets of discontinued operations	<u>\$11.6</u>	<u>\$10.4</u>	
Accrued expenses and other liabilities	<u>\$29.7</u>	<u>\$28.6</u>	
Liabilities of discontinued operations	<u>\$29.7</u>	<u>\$28.6</u>	

The assets and liabilities for 2008 and 2007 primarily relate to reserves for the James Jones Litigation. Statements of Cash Flows amounts for 2008, 2007 and 2006 relate to operating activities.

Watts Water Technologies, Inc. and Subsidiaries
Notes to Consolidated Financial Statements (Continued)

(4) Restructuring and Other (Income) Charges

During 2007, the Company undertook a review of certain product lines and its overall manufacturing capacity. Based on that review, the Company initiated a global restructuring program that was approved by the Company's Board of Directors on October 30, 2007. The Company also discontinued certain product lines. This program is expected to include the shutdown of five manufacturing facilities and the rightsizing of a sixth facility, including the relocation of its joint venture facility in China that was previously disclosed. The restructuring program and charges for certain product line discontinuances include pre-tax charges totaling approximately \$12.9 million. Charges are primarily for severance (\$4.3 million), relocation costs (\$2.8 million) and other asset write-downs and expected net losses on asset disposals (\$2.0 million) and will result in the elimination of approximately 330 positions worldwide. The product lines that were discontinued and accelerated depreciation resulted in a pre-tax charge of \$4.3 million during 2007. Total net after-tax charges for this program are expected to be approximately \$9.4 million (\$4.4 million non-cash), with costs being incurred through 2010. The Company expects to spend approximately \$13.4 million in capital expenditures to consolidate operations and will fund approximately \$8.0 million of this amount through proceeds from the sale of buildings and other assets being disposed of as part of the restructuring program. Annual cash savings, net of tax, are estimated to be \$4.5 million, which will be fully realized by the second half of 2010.

The following table presents the total estimated pre-tax charges to be incurred for the global restructuring program and product line discontinuances initiated in 2007 by the Company's reportable segments:

<u>Reportable Segment</u>	<u>Total</u>	<u>Spent to Date</u>
	(in millions)	
North America	\$ 5.7	\$5.8
Europe	3.9	0.2
China	3.3	2.9
Total	<u>\$12.9</u>	<u>\$8.9</u>

For 2008, the Company recorded pre-tax charges of approximately \$5.7 million. Pre-tax costs of \$0.3 million recorded in costs of goods sold were primarily for accelerated depreciation. Pre-tax costs of \$5.6 million recorded in restructuring and other charges were primarily severance costs, asset write-downs, accelerated depreciation related to the Company's relocation of its then 60% owned Chinese joint venture. The Company also recognized income of \$0.2 million in minority interest representing the 40% liability of its Chinese joint venture partner in the restructuring plan.

For 2007, the Company recorded pre-tax charges of approximately \$7.5 million. Pre-tax costs of \$4.3 million recorded in costs of goods sold were primarily for product line discontinuances. Pre-tax costs of \$3.2 million recorded in restructuring and other charges were primarily for asset write-downs related to the Company's wholly owned Chinese manufacturing plants, accelerated depreciation related to the Company's relocation of its then 60% owned Chinese joint venture and severance costs in both China and North America. The Company also recognized income of \$0.9 million in minority interest representing the 40% liability of its then Chinese joint venture partners in the restructuring plan.

For 2006, the Company recorded charges of \$4.7 million in costs of goods sold primarily for manufacturing severance costs related to the Company's relocation plan for its then 60% owned Chinese joint venture. The Company recorded income of \$5.7 million to restructuring and other (income) charges which is primarily comprised of gains of approximately \$8.2 million related to the sales of buildings in Italy, partially offset by charges of approximately \$2.1 million for severance costs

Watts Water Technologies, Inc. and Subsidiaries
Notes to Consolidated Financial Statements (Continued)

(4) Restructuring and Other (Income) Charges (Continued)

related to the Company's European restructuring plans and approximately \$0.4 million for accelerated amortization related to the Company's Chinese restructuring plan. The Company also recognized income of \$1.5 million in minority interest representing the 40% liability of its then Chinese joint venture partners.

With respect to the table below, restructuring costs consist primarily of severance costs. In 2007, severance costs were recorded in restructuring and other charges (income) and, in 2006, were recorded in cost of goods sold. Asset write-downs consist primarily of write-offs of fixed assets and accelerated depreciation. Product line discontinuances consist of inventory write-offs related to product lines the Company has discontinued and are recorded in cost of goods sold. Other costs consist of gains on sales of buildings in 2006 and of removal and shipping costs associated with relocation of manufacturing equipment in 2007.

Details of the Company's manufacturing restructuring plans through December 31, 2008 are as follows:

	<u>Restructuring</u>	<u>Asset write-downs</u>	<u>Product line discontinuance</u> (in millions)	<u>Other costs</u>	<u>Minority interest</u>	<u>Total</u>
Balance as of December 31, 2005	\$ —	\$ —	\$ —	\$ —	\$ —	\$ —
Provisions during 2006	6.7	0.5	—	(8.2)	(1.5)	(2.5)
Utilized during 2006	<u>(2.5)</u>	<u>(0.5)</u>	<u>—</u>	<u>8.2</u>	<u>1.5</u>	<u>6.7</u>
Balance as of December 31, 2006	4.2	—	—	—	—	4.2
Provisions during 2007	0.8	2.8	3.8	0.1	(0.9)	6.6
Utilized during 2007	<u>(2.6)</u>	<u>(2.8)</u>	<u>(3.8)</u>	<u>(0.1)</u>	<u>0.9</u>	<u>(8.4)</u>
Balance as of December 31, 2007	2.4	—	—	—	—	2.4
Provisions during 2008	3.7	0.6	—	1.6	(0.2)	5.7
Utilized during 2008	<u>(6.1)</u>	<u>(0.6)</u>	<u>—</u>	<u>(1.6)</u>	<u>0.2</u>	<u>(8.1)</u>
Balance as of December 31, 2008	<u>\$ —</u>	<u>\$ —</u>	<u>\$ —</u>	<u>\$ —</u>	<u>\$ —</u>	<u>\$ —</u>

Watts Water Technologies, Inc. and Subsidiaries
Notes to Consolidated Financial Statements (Continued)

(5) Business Acquisitions and Disposition

On May 30, 2008, the Company acquired all of the outstanding stock of Blücher for approximately \$183.5 million. The purchase price consisted of \$170.1 million in cash and the assumption of debt of \$13.4 million, net of cash acquired. Blücher is a leading provider of stainless steel drainage systems in Europe to the residential, commercial and industrial market places and is a worldwide leader in providing stainless steel drainage products to the marine industry. Blücher provides the Company with a new product platform in Europe while allowing the Company to offer a broader product line to its existing customer base. The Company is accounting for the transaction as a business combination under FAS No. 141, "Business Combinations." The Company completed a purchase price allocation that resulted in the recognition of \$64.5 million in intangible assets and \$89.5 million in goodwill. Intangible assets are comprised primarily of customer relationships and patents with estimated lives of 10 years and trade names with indefinite lives. The consolidated results of operations include the results of Blücher since the acquisition date of May 30, 2008. Had the Company completed the acquisition at the beginning of 2007, the net sales, income from continuing operations and earnings per share from continuing operations would have been as follows:

Amounts in millions (except per share information) (unaudited)

	Twelve Months Ended	
	December 31, 2008	December 31, 2007
Net sales	\$1,500.7	\$1,460.2
Income from continuing operations	\$ 54.3	\$ 75.1
Net income	\$ 53.6	\$ 74.9
Basic EPS—Net income	\$ 1.47	\$ 1.94
Diluted EPS—Net income	\$ 1.46	\$ 1.92

During the second quarter of 2008, the Company completed the acquisition of the remaining 40% ownership of its joint venture in China, TWT, for \$3.3 million in cash. TWT manufactured products to support the U.S. operations as well as to sell into the local China market. In the third quarter of 2008, the Company relocated the business supporting the U.S. from TWT into an existing operation in China. The Company then entered into an agreement to sell TWT. Under this agreement, the Company determined that the risks and rewards of ownership of TWT were effectively transferred to the buyer as of October 18, 2008. The Company further determined that it was no longer the primary beneficiary of the operating results of TWT and therefore deconsolidated TWT as of October 18, 2008. As the equity transfer from the Company to the buyer has not yet been approved by local authorities, the Company deferred a \$1.1 million gain from the sale. Upon final approval of the transfer by Chinese government authority, the Company expects to recognize the gain during 2009. The deferred gain has been recorded as a current liability in the accompanying Consolidated Balance Sheet.

On November 9, 2007, the Company acquired the assets and business of Topway located in Brea, California for approximately \$18.4 million. The allocations for goodwill and intangible assets were approximately \$7.6 million and \$8.2 million, respectively. The amount recorded as intangible assets is primarily for customer relationships with an estimated useful life of 10 years and trade names with indefinite lives. Topway manufactures a wide variety of water softeners, point-of-entry filter units, and point-of-use drinking water systems for residential, commercial and industrial applications.

Certain acquisition agreements from prior years contain either an earn-out provision or a put feature on the remaining common stock not yet purchased by the Company. In 2008, the Company accrued approximately \$0.4 million for an earn-out provision which was charged to goodwill and will be paid in 2009. In 2007, the Company accrued approximately \$3.8 million in earn-out provisions which

Watts Water Technologies, Inc. and Subsidiaries
Notes to Consolidated Financial Statements (Continued)

(5) Business Acquisitions and Disposition (Continued)

were charged to goodwill and paid in 2008. In 2006, the Company accrued approximately \$4.0 million in earn-out provisions which were charged to goodwill and paid in 2007. The calculations are typically based on a multiple of future gross margins or operating earnings as defined in the agreements.

(6) Accumulated Other Comprehensive Income (Loss)

Accumulated other comprehensive income (loss) consist of the following:

	<u>Foreign Currency Translation</u>	<u>Defined Benefit Pension Plans</u>	<u>Accumulated Other Comprehensive Income/(Loss)</u>
		(in millions)	
Balance December 31, 2006	\$ 38.1	\$(12.7)	\$ 25.4
Change in period	<u>39.1</u>	<u>4.2</u>	<u>43.3</u>
Balance December 31, 2007	77.2	(8.5)	68.7
Change in period	<u>(51.8)</u>	<u>(16.7)</u>	<u>(68.5)</u>
Balance December 31, 2008	<u>\$ 25.4</u>	<u>\$(25.2)</u>	<u>\$ 0.2</u>

(7) Inventories, net

Inventories consist of the following:

	<u>December 31,</u>	
	<u>2008</u>	<u>2007</u>
	(in millions)	
Raw materials	\$107.4	\$108.9
Work in process	44.9	45.7
Finished goods	186.7	187.0
	<u>\$339.0</u>	<u>\$341.6</u>

Finished goods of \$19.1 million and \$20.3 million as of December 31, 2008 and 2007, respectively, were consigned.

(8) Property, Plant and Equipment

Property, plant and equipment consists of the following:

	<u>December 31,</u>	
	<u>2008</u>	<u>2007</u>
	(in millions)	
Land	\$ 14.9	\$ 13.7
Buildings and improvements	149.4	132.6
Machinery and equipment	293.5	270.5
Construction in progress	<u>7.6</u>	<u>20.6</u>
	465.4	437.4
Accumulated depreciation	<u>(228.0)</u>	<u>(213.7)</u>
	<u>\$ 237.4</u>	<u>\$ 223.7</u>

Watts Water Technologies, Inc. and Subsidiaries
Notes to Consolidated Financial Statements (Continued)

(9) Income Taxes

The significant components of the Company's deferred income tax liabilities and assets are as follows:

	December 31,	
	2008	2007
	(in millions)	
Deferred income tax liabilities:		
Excess tax over book depreciation	\$15.9	\$15.3
Intangibles	33.3	23.5
Other	8.5	12.4
Total deferred tax liabilities	57.7	51.2
Deferred income tax assets:		
Accrued expenses	23.8	22.0
Net operating loss carry-forward	4.3	3.2
Inventory reserves	10.3	13.7
Other	29.1	10.7
Total deferred tax assets	67.5	49.6
Less: valuation allowance	(4.7)	(3.2)
Net deferred tax assets	62.8	46.4
Net deferred tax (assets)/liabilities	\$ 5.1	\$(4.8)

The provision for income taxes from continuing operations is based on the following pre-tax income:

	Years Ended December 31,		
	2008	2007	2006
	(in millions)		
Domestic	\$ 0.9	\$ 47.6	\$ 49.6
Foreign	71.4	66.2	66.5
	\$72.3	\$113.8	\$116.1

Watts Water Technologies, Inc. and Subsidiaries
Notes to Consolidated Financial Statements (Continued)

(9) Income Taxes (Continued)

The provision for income taxes from continuing operations consists of the following:

	Years Ended December 31,		
	2008	2007	2006
	(in millions)		
Current tax expense:			
Federal	\$ 7.6	\$19.2	\$18.0
Foreign	24.7	20.4	20.5
State	1.9	4.8	4.1
	34.2	44.4	42.6
Deferred tax expense (benefit):			
Federal	(0.2)	(5.7)	(1.7)
Foreign	(7.7)	(1.2)	(1.5)
State	(1.3)	(1.3)	(0.4)
	(9.2)	(8.2)	(3.6)
	\$25.0	\$36.2	\$39.0

Actual income taxes reported from continuing operations are different than would have been computed by applying the federal statutory tax rate to income from continuing operations before income taxes. The reasons for this difference are as follows:

	Years Ended December 31,		
	2008	2007	2006
	(in millions)		
Computed expected federal income expense	\$25.3	\$39.8	\$40.6
State income taxes, net of federal tax benefit	0.4	2.3	2.4
Foreign tax rate differential	(8.0)	(7.2)	(4.4)
Valuation allowance	4.2	3.2	—
Goodwill impairment	3.2	—	—
Other, net	(0.1)	(1.9)	0.4
	\$25.0	\$36.2	\$39.0

At December 31, 2008, the Company has foreign net operating loss carry forwards of \$16.1 million for income tax purposes; \$6.2 million of the losses can be carried forward indefinitely, \$4.9 million of the losses expire in 2016, and \$5.0 million expire in 2017. The net operating losses consist of \$5.0 million related to German operations, \$1.2 million to Austrian operations, and \$9.9 million to Netherland operations.

At December 31, 2008, the Company had a valuation allowance of \$4.7 million for a capital loss sustained in the U.S., as management believes it is not more likely than not that the Company would use such loss within the applicable carryforward period. The entire \$3.2 million beginning of year valuation allowance pertained to TWT, a Chinese subsidiary which was disposed of in 2008. The Company does not have a valuation allowance on other deferred tax assets, as management believes that it is more likely than not that the Company will recover the net deferred tax assets.

Watts Water Technologies, Inc. and Subsidiaries
Notes to Consolidated Financial Statements (Continued)

(9) Income Taxes (Continued)

Enacted changes in income tax laws had no material effect on the Company in 2008, 2007 or 2006.

Undistributed earnings of the Company's foreign subsidiaries amounted to approximately \$312.5 million at December 31, 2008, \$251.6 million at December 31, 2007 and \$168.9 million at December 31, 2006. Those earnings are considered to be indefinitely reinvested and, accordingly, no provision for U.S. federal and state income taxes has been recorded thereon. Upon distribution of those earnings, in the form of dividends or otherwise, the Company will be subject to withholding taxes payable to the various foreign countries. Determination of the amount of U.S. income tax liability that would be incurred is not practicable because of the complexities associated with its hypothetical calculation; however, unrecognized foreign tax credits may be available to reduce some portion of any U.S. income tax liability. Withholding taxes of approximately \$6.1 million would be payable upon remittance of all previously unremitted earnings at December 31, 2008.

(10) Accrued Expenses and Other Liabilities

Accrued expenses and other liabilities consist of the following:

	December 31,	
	2008	2007
	<i>(in millions)</i>	
Commissions and sales incentives payable	\$ 41.2	\$ 42.6
Accrued product liability and workers' compensation	30.5	26.1
Other	28.1	38.5
Income taxes payable	4.1	6.4
	\$103.9	\$113.6

Watts Water Technologies, Inc. and Subsidiaries
Notes to Consolidated Financial Statements (Continued)

(11) Financing Arrangements

Long-term debt consists of the following:

	December 31,	
	2008	2007
	(in millions)	
5.85% notes due April 2016	\$225.0	\$225.0
4.87% notes due May 2010	50.0	50.0
5.47% notes due May 2013	75.0	75.0
\$350.0 million Revolving Credit Facility maturing in April 2011. Eurocurrency rate loans interest accruing at LIBOR or Euro LIBOR plus an applicable percentage (Euro LIBOR at 0.4% and 4.7% at December 31, 2008 and 2007, respectively) At December 31, 2008, \$55.0 million was for euro based borrowings and there were no outstanding U.S. borrowings. At December 31, 2007, \$81.8 million were for euro based borrowings and there were no outstanding U.S. borrowings.	55.0	81.8
Other—consists primarily of European borrowings (at interest rates ranging from 4.1% to 6.0%)	9.3	1.7
	414.3	433.5
Less Current Maturities	4.5	1.3
	\$409.8	\$432.2

Principal payments during each of the next five years and thereafter are due as follows (in millions): 2009—\$4.5; 2010—\$50.8; 2011—\$55.7; 2012—\$0.8; 2013—\$75.7 and thereafter—\$226.8.

The Company maintains letters of credit that guarantee its performance or payment to third parties in accordance with specified terms and conditions. Amounts outstanding were approximately \$39.3 million as of December 31, 2008 and \$45.0 million as of December 31, 2007. The Company's letters of credit are primarily associated with insurance coverage and to a lesser extent foreign purchases. The Company's letters of credit generally expire within one year of issuance and are drawn down against the revolving credit facility. These instruments may exist or expire without being drawn down. Therefore, they do not necessarily represent future cash flow obligations.

On April 27, 2006, the Company completed a private placement of \$225.0 million of 5.85% senior unsecured notes due April 2016 (the 2006 Note Purchase Agreement). The 2006 Note Purchase Agreement includes operational and financial covenants, with which the Company is required to comply, including, among others, maintenance of certain financial ratios and restrictions on additional indebtedness, liens and dispositions. Events of default under the 2006 Note Purchase Agreement include failure to comply with its financial and operational covenants, as well as bankruptcy and other insolvency events. The Company may, at its option, upon notice to the noteholders, prepay at any time all or part of the Notes in an amount not less than \$1.0 million by paying the principal amount plus a make-whole amount, which is dependent upon the yield of respective U.S. Treasury Securities. As of December 31, 2008, the Company was in compliance with all covenants related to the 2006 Note Purchase Agreement. The payment of interest on the senior unsecured notes is due semi-annually on April 30th and October 30th of each year. Additionally, the Company amended its 2003 Note Purchase Agreement to reflect the existence of the subsidiary guarantors and to substantially conform certain provisions of the 2003 Note Purchase Agreement to the 2006 Note Purchase Agreement.

Watts Water Technologies, Inc. and Subsidiaries
Notes to Consolidated Financial Statements (Continued)

(11) Financing Arrangements (Continued)

On April 27, 2006, the Company amended and restated its unsecured revolving credit facility with a syndicate of banks (as amended, the revolving credit facility). The revolving credit facility provides for multi-currency unsecured borrowings and stand-by letters of credit of up to \$350.0 million and expires in April 2011. Borrowings outstanding under the revolving credit facility bear interest at a fluctuating rate per annum equal to an applicable percentage equal to (i) in the case of Eurocurrency rate loans, the British Bankers Association LIBOR rate plus an applicable percentage of 0.625%, which is determined by reference to the Company's consolidated leverage ratio and debt rating, or (ii) in the case of base rate loans and swing line loans, the higher of (a) the federal funds rate plus 0.5% and (b) the rate of interest in effect for such day as announced by Bank of America, N.A. as its "prime rate." For 2008, the average interest rate under the revolving credit facility for euro-based borrowings was approximately 5.2%. The revolving credit facility includes operational and financial covenants customary for facilities of this type, including, among others, restrictions on additional indebtedness, liens and investments and maintenance of certain leverage ratios. As of December 31, 2008, the Company was in compliance with all covenants related to the revolving credit facility; had \$260.0 million of unused and potentially available credit under the revolving credit facility; had no U.S. dollar denominated debt and \$55.0 million of euro-based borrowings outstanding on its revolving credit facility; and had \$35.0 million for stand-by letters of credit outstanding on its revolving credit facility.

On May 15, 2003, the Company completed a private placement of \$125.0 million of senior unsecured notes consisting of \$50.0 million principal amount of 4.87% senior notes due 2010 and \$75.0 million principal amount of 5.47% senior notes due 2013. The payment of interest on the senior unsecured notes is due semi-annually on May 15th and November 15th of each year. The senior unsecured notes were issued by Watts Water Technologies, Inc. and are *pari passu* with the revolving credit facility. The senior unsecured notes allow the Company to have (i) debt senior to the notes in an amount up to \$150.0 million plus 5% of stockholders' equity and (ii) debt *pari passu* or junior to the senior unsecured notes to the extent the Company maintains compliance with a 2.0 to 1.0 fixed charge coverage ratio. The notes include a prepayment provision which might require a make-whole payment to the note holders. Such payment is dependent upon the level of the respective treasuries. The notes include other customary terms and conditions, including events of default.

(12) Common Stock

The Class A Common Stock and Class B Common Stock have equal dividend and liquidation rights. Each share of the Company's Class A Common Stock is entitled to one vote on all matters submitted to stockholders and each share of Class B Common Stock is entitled to ten votes on all such matters. Shares of Class B Common Stock are convertible into shares of Class A Common Stock, on a one-to-one basis, at the option of the holder. As of December 31, 2008, the Company has reserved a total of 4,340,324 of Class A Common Stock for issuance under its stock-based compensation plans and 7,293,880 shares for conversion of Class B Common Stock to Class A Common Stock.

In November 2007, the Company announced that its Board of Directors had authorized a repurchase of up to 3,000,000 shares of its Class A Common Stock. As of December 31, 2008, the Company had repurchased 2.45 million shares of stock for a total cost of \$68.1 million.

(13) Stock-Based Compensation

The Company maintains three stock incentive plans under which key employees and outside directors have been granted incentive stock options (ISOs) and nonqualified stock options (NSOs) to purchase the Company's Class A Common Stock. Only one plan, the 2004 Stock Incentive Plan, is

Watts Water Technologies, Inc. and Subsidiaries
Notes to Consolidated Financial Statements (Continued)

(13) Stock-Based Compensation (Continued)

currently available for the grant of new equity awards. Stock options granted under prior plans became exercisable over a five-year period at the rate of 20% per year and expire ten years after the date of grant. Under the 2004 Stock Incentive Plan, options become exercisable over a four-year period at the rate of 25% per year and expire ten years after the grant date. ISOs and NSOs granted under the plans may have exercise prices of not less than 100% and 50% of the fair market value of the Class A Common Stock on the date of grant, respectively. The Company's current practice is to grant all options at fair market value on the grant date. At December 31, 2008, 2,827,218 shares of Class A Common Stock were authorized for future grants of new equity awards under the Company's stock incentive plans.

The Company also grants shares of restricted stock to key employees and non-employee members of the Company's Board of Directors under the 2004 Stock Incentive Plan, which vest either immediately or over a three-year period at the rate of one-third per year. The restricted stock awards are amortized to expense on a straight-line basis over the vesting period.

The Company also has a Management Stock Purchase Plan that allows for the granting of restricted stock units (RSUs) to key employees. On an annual basis, key employees may elect to receive a portion of their annual incentive compensation in RSUs instead of cash. Each RSU provides the key employee with the right to purchase a share of Class A Common Stock at 67% of the fair market value on the date of grant. RSUs vest annually over a three-year period from the grant date. An aggregate of 2,000,000 shares of Class A Common Stock may be issued under the Management Stock Purchase Plan.

2004 Stock Incentive Plan

At December 31, 2008, total unrecognized compensation cost related to the unvested stock options was approximately \$3.7 million with a total weighted average remaining term of 2.8 years. For 2008, 2007 and 2006, the Company recognized compensation cost of \$2.3 million, \$2.7 million and \$1.4 million, respectively, in selling, general and administrative expenses.

The following is a summary of stock option activity and related information:

	Years Ended December 31,						
	2008		Intrinsic Value	2007		2006	
Options	Weighted Average Exercise Price	Options		Weighted Average Exercise Price	Options	Weighted Average Exercise Price	Options
		(Options in thousands)					
Outstanding at beginning of year . . .	1,168	\$25.32	\$ —	1,140	\$23.99	1,089	\$21.70
Granted	202	29.35		189	33.36	164	35.20
Cancelled/Forfeitures	(68)	31.68		(94)	31.08	(7)	34.16
Exercised	(86)	19.08		(67)	17.17	(106)	17.61
Outstanding at end of year	<u>1,216</u>	<u>\$26.07</u>		<u>1,168</u>	<u>\$25.32</u>	<u>1,140</u>	<u>\$23.99</u>
Exercisable at end of year	<u>800</u>	<u>\$23.22</u>	<u>\$1.75</u>	<u>705</u>	<u>\$21.42</u>	<u>566</u>	<u>\$19.13</u>

Watts Water Technologies, Inc. and Subsidiaries
Notes to Consolidated Financial Statements (Continued)

(13) Stock-Based Compensation (Continued)

As of December 31, 2008, the aggregate intrinsic values of exercisable options were approximately \$1.4 million, representing the total pre-tax intrinsic value, based on the Company's closing Class A Common Stock price of \$24.97 as of December 31, 2008, which would have been received by the option holders had all option holders exercised their options as of that date. The total intrinsic value of options exercised for 2008, 2007 and 2006 was approximately \$0.8 million, \$1.4 million and \$2.2 million, respectively.

Upon exercise of options, the Company issues shares of Class A Common Stock.

The following table summarizes information about options outstanding at December 31, 2008:

Range of Exercise Prices	Options Outstanding			Options Exercisable	
	Number Outstanding	Weighted Average Remaining Contractual Life (years)	Weighted Average Exercise Price	Number Exercisable	Weighted Average Exercise Price
			(Options in thousands)		
\$10.56—\$14.08	43	2.38	\$10.99	43	\$10.99
\$14.09—\$17.60	337	3.91	16.53	337	16.53
\$24.64—\$28.16	167	5.59	25.02	167	25.02
\$28.17—\$31.68	200	9.58	29.35	—	29.35
\$31.69—\$35.20	469	7.48	33.28	253	33.04
	<u>1,216</u>	6.40	\$26.07	<u>800</u>	\$23.22

The fair value of each option granted under the 2004 Stock Incentive Plan is estimated on the date of grant, using the Black-Scholes-Merton Model, based on the following weighted average assumptions:

	Years Ended December 31,		
	2008	2007	2006
Expected life (years)	6.0	5.8	5.8
Expected stock price volatility	35.6%	37.2%	35.9%
Expected dividend yield	1.5%	1.2%	1.0%
Risk-free interest rate	3.5%	4.6%	4.9%

The risk-free interest rate is based upon the U.S. Treasury yield curve at the time of grant for the respective expected life of the option. The expected life (estimated period of time outstanding) of options and volatility were calculated using historical data. The expected dividend yield of stock is the Company's best estimate of the expected future dividend yield. The Company applied an estimated forfeiture rate of 15% for its stock options. These rates were calculated based upon historical activity and are an estimate of granted shares not expected to vest. If actual forfeitures differ from the expected rates, the Company may be required to make additional adjustments to compensation expense in future periods.

The above assumptions were used to determine the weighted average grant-date fair value of stock options of \$10.10, \$12.75 and \$13.50 for the years ending December 31, 2008, 2007 and 2006, respectively.

Watts Water Technologies, Inc. and Subsidiaries
Notes to Consolidated Financial Statements (Continued)

(13) Stock-Based Compensation (Continued)

The following is a summary of unvested restricted stock activity and related information:

	Years Ended December 31,					
	2008		2007		2006	
	Shares	Weighted Average Grant Date Fair Value	Shares	Weighted Average Grant Date Fair Value	Shares	Weighted Average Grant Date Fair Value
			(Shares in thousands)			
Unvested at beginning of year	89	\$34.05	73	\$33.62	27	\$26.51
Granted	80	29.35	74	33.21	60	35.27
Forfeitures	(7)	33.71	(15)	34.10	(1)	35.20
Vested	(47)	32.92	(43)	31.85	(13)	26.09
Unvested at end of year	<u>115</u>	<u>\$31.27</u>	<u>89</u>	<u>\$34.05</u>	<u>73</u>	<u>\$33.62</u>

The total fair value of shares vested during 2008, 2007 and 2006 was \$1.4 million, \$1.4 million and \$0.4 million, respectively. At December 31, 2008, total unrecognized compensation cost related to unvested restricted stock was approximately \$2.7 million with a total weighted average remaining term of 1.5 years. For 2008, 2007 and 2006, the Company recognized compensation costs of \$1.8 million, \$1.6 million and \$0.6 million, respectively, in selling, general and administrative expenses. The Company applied an estimated forfeiture rate of 10% for restricted stock issued to key employees. The aggregate intrinsic value of restricted stock granted and outstanding approximated \$2.9 million representing the total pre-tax intrinsic value based on the Company's closing Class A Common Stock price of \$24.97 as of December 31, 2008.

Management Stock Purchase Plan

Total unrecognized compensation cost related to unvested RSUs was approximately \$1.2 million at December 31, 2008 with a total weighted average remaining term of 1.5 years. For 2008, 2007 and 2006 the Company recognized compensation cost of \$1.2 million, \$1.7 million and \$1.0 million, respectively, in selling, general and administrative expenses. Dividends declared for RSUs, that are paid to individuals, that remain unpaid at December 31, 2008 total approximately \$0.2 million.

Watts Water Technologies, Inc. and Subsidiaries
Notes to Consolidated Financial Statements (Continued)

(13) Stock-Based Compensation (Continued)

A summary of the Company's RSUs activity and related information for 2008 is shown in the following table:

	Years Ended December 31,						
	2008		2007		2006		
	RSUs	Weighted Average Purchase Price	Intrinsic Value	RSUs	Weighted Average Purchase Price	RSUs	Weighted Average Purchase Price
	(RSUs in thousands)						
Outstanding at beginning of period	366	\$18.98		347	\$19.00	328	\$16.02
Granted	60	19.09		160	25.73	87	23.34
Cancelled/Forfeitures	(19)	23.23		(31)	25.03	—	—
Settled	(110)	22.06		(110)	15.62	(68)	10.20
Outstanding at end of period . . .	<u>297</u>	<u>\$21.86</u>	<u>\$3.11</u>	<u>366</u>	<u>\$22.45</u>	<u>347</u>	<u>\$19.00</u>
Vested at end of period	<u>133</u>	<u>\$20.27</u>	<u>\$4.70</u>	<u>141</u>	<u>\$18.98</u>	<u>148</u>	<u>\$15.64</u>

As of December 31, 2008, the aggregate intrinsic values of outstanding and vested RSUs were approximately \$0.9 million and \$0.6 million, respectively, representing the total pre-tax intrinsic value, based on the Company's closing Class A Common Stock price of \$24.97 as of December 31, 2008 which would have been received by the RSUs holders had all RSUs settled as of that date. The total intrinsic value of RSUs settled for 2008, 2007 and 2006 was approximately \$0.7 million, \$2.5 million and \$1.4 million, respectively. Upon settlement of RSUs, the Company issues shares of Class A Common Stock.

The following table summarizes information about RSUs outstanding at December 31, 2008:

Range of Purchase Prices	RSUs Outstanding			RSUs Vested	
	Number Outstanding	Weighted Average Remaining Contractual Life (years)	Weighted Average Purchase Price	Number Vested	Weighted Average Purchase Price
	(RSUs in thousands)				
\$7.04—\$10.56	32	2.5	\$ 9.54	32	\$ 9.54
\$14.08—\$17.60	7	0.2	15.50	7	15.50
\$17.61—\$21.11	54	2.2	19.09	—	—
\$21.12—\$24.64	80	0.3	23.27	53	23.23
\$24.65—\$25.73	124	1.2	25.73	41	25.73
	<u>297</u>	1.2	<u>\$21.86</u>	<u>133</u>	<u>\$20.27</u>

Watts Water Technologies, Inc. and Subsidiaries
Notes to Consolidated Financial Statements (Continued)

(13) Stock-Based Compensation (Continued)

The fair value of each share issued under the Management Stock Purchase Plan is estimated on the date of grant, using the Black-Scholes-Merton Model, based on the following weighted average assumptions:

	Years Ended December 31,		
	2008	2007	2006
Expected life (years)	3.0	3.0	3.0
Expected stock price volatility	37.2%	35.3%	25.7%
Expected dividend yield	1.5%	1.0%	1.5%
Risk-free interest rate	2.2%	4.8%	4.5%

The risk-free interest rate is based upon the U.S. Treasury yield curve at the time of grant for the respective expected life of the RSU's. The expected life (estimated period of time outstanding) of RSU's and volatility were calculated using historical data. The expected dividend yield of stock is the Company's best estimate of the expected future dividend yield. The Company applied an estimated forfeiture rate of 10% for its RSUs. These rates were calculated based upon historical activity and are an estimate of granted shares not expected to vest. If actual forfeitures differ from the expected rates, the Company may be required to make additional adjustments to compensation expense in future periods.

The above assumptions were used to determine the weighted average grant-date fair value of RSUs granted of \$11.44, \$16.79 and \$13.60 during 2008, 2007 and 2006, respectively.

The Company distributed dividends of \$0.44 per share for 2008, \$0.40 per share for 2007 and \$0.36 per share for 2006 on the Company's Class A Common Stock and Class B Common Stock.

(14) Employee Benefit Plans

The Company sponsors funded and unfunded non-contributing defined benefit pension plans that together cover substantially all of its domestic employees. Benefits are based primarily on years of service and employees' compensation. The funding policy of the Company for these plans is to contribute an annual amount that does not exceed the maximum amount that can be deducted for federal income tax purposes. Beginning in 2007, the Company uses a December 31 measurement date for its plans. Prior to 2007, the Company used a September 30 measurement date for its plans.

Watts Water Technologies, Inc. and Subsidiaries
Notes to Consolidated Financial Statements (Continued)

(14) Employee Benefit Plans (Continued)

The funded status of the defined benefit plans and amounts recognized in the consolidated balance sheet are as follows:

	<u>December 31,</u>	
	<u>2008</u>	<u>2007</u>
	(in millions)	
Change in projected benefit obligation		
Balance at beginning of the year	\$ 73.4	\$ 72.6
Service cost	3.4	3.8
Administration cost	(0.8)	(0.4)
Plan change	0.8	0.1
Interest cost	4.7	4.3
Actuarial loss (gain)	8.1	(6.0)
Benefits paid	(2.5)	(2.3)
One-time adjustment for measurement date change	—	1.3
Balance at end of year	<u>\$ 87.1</u>	<u>\$ 73.4</u>
Change in fair value of plan assets		
Balance at beginning of the year	\$ 58.8	\$ 42.6
Actual (loss) gain on assets	(13.8)	3.6
Employer contributions	3.2	7.3
Administration cost	(0.8)	(0.4)
Benefits paid	(2.5)	(2.3)
One-time adjustment for measurement date change	—	8.0
Fair value of plan assets at end of the year	<u>\$ 44.9</u>	<u>\$ 58.8</u>
Funded status at end of year	<u>\$ (42.2)</u>	<u>\$ (14.6)</u>

Amounts recognized in the consolidated balance sheet are as follows:

	<u>December 31,</u>	
	<u>2008</u>	<u>2007</u>
	(in millions)	
Current liabilities	\$ (0.1)	\$ (0.1)
Noncurrent liabilities	(42.1)	(14.5)
Net amount recognized	<u>\$ (42.2)</u>	<u>\$ (14.6)</u>

Amounts recognized in accumulated other comprehensive income consist of:

	<u>December 31,</u>	
	<u>2008</u>	<u>2007</u>
	(in millions)	
Net actuarial loss	\$37.6	\$11.2
Prior service cost	2.3	1.8
Net amount recognized	<u>\$39.9</u>	<u>\$13.0</u>

Watts Water Technologies, Inc. and Subsidiaries
Notes to Consolidated Financial Statements (Continued)

(14) Employee Benefit Plans (Continued)

Information for pension plans with an accumulated benefit obligation in excess of plan assets are as follows:

	December 31,	
	2008	2007
	(in millions)	
Projected benefit obligation	\$87.1	\$73.4
Accumulated benefit obligation	\$78.0	\$66.4
Fair value of plan assets	\$44.9	\$58.8

The components of net periodic benefit cost are as follows:

	Years Ended December 31,		
	2008	2007	2006
	(in millions)		
Service cost—benefits earned	\$ 3.4	\$ 3.8	\$ 3.5
Interest costs on benefits obligation	4.7	4.3	3.8
Expected return on assets	(4.9)	(4.4)	(3.5)
Prior service cost amortization	0.2	0.2	0.3
Net actuarial loss amortization	0.4	0.9	1.2
Curtailment charge	—	0.2	—
Net periodic benefit cost	<u>\$ 3.8</u>	<u>\$ 5.0</u>	<u>\$ 5.3</u>

The estimated net actuarial loss and prior service cost for the defined benefit pension plans that will be amortized from accumulated other comprehensive income into net periodic benefit cost over the next year are \$2.9 million and \$0.2 million, respectively.

Assumptions:

Weighted-average assumptions used to determine benefit obligations:

	2008	2007
Discount rate	6.00%	6.50%
Rate of compensation increase	4.00%	4.00%

Weighted-average assumptions used to determine net periodic benefit costs:

	2008	2007	2006
Discount rate	6.00%	5.87%	5.50%
Long-term rate of return on assets	8.50%	8.50%	8.50%
Rate of compensation increase	4.00%	4.00%	4.00%

Discount rates are selected based upon rates of return at the measurement date utilizing a bond matching approach to match the expected benefit cash flows. In selecting the expected long-term rate of return on assets, the Company considers the average rate of earnings expected on the funds invested or to be invested to provide for the benefits of this plan. This includes considering the trust's asset allocation and the expected returns likely to be earned over the life of the plan. This basis is consistent with the prior year.

Watts Water Technologies, Inc. and Subsidiaries
Notes to Consolidated Financial Statements (Continued)

(14) Employee Benefit Plans (Continued)

Plan assets:

The weighted average asset allocations by asset category is as follows:

<u>Asset Category</u>	<u>2008</u>	<u>2007</u>
Equity securities	50.3%	64.9%
Debt securities	45.7	29.8
Other	4.0	5.3
Total	<u>100.0%</u>	<u>100.0%</u>

The Company's written Retirement Plan Investment Policy sets forth the investment policy, objectives and constraints of the Watts Water Technologies, Inc. Pension Plan. This Retirement Plan Investment Policy, set forth by the Pension Plan Committee, defines general investment principles and directs investment management policy, addressing preservation of capital, risk aversion and adherence to investment discipline. Investment managers are to make a reasonable effort to control risk and are evaluated quarterly against commonly accepted benchmarks to ensure that the risk assumed is commensurate with the given investment style and objectives.

The portfolio is designed to achieve a balanced return of current income and modest growth of capital, while achieving returns in excess of the rate of inflation over the investment horizon in order to preserve purchasing power of Plan assets. All Plan assets are required to be invested in liquid securities. Derivative investments are not allowed.

Prohibited investments include, but are not limited to the following: commodities and futures contracts, private placements, options, limited partnerships, venture-capital investments, real estate properties, interest-only (IO), principal-only (PO), and residual tranche CMOs, and Watts Water Technologies, Inc. stock.

Prohibited transactions include, but are not limited to the following: short selling and margin transactions.

Allowable assets include: cash equivalents, fixed income securities, equity securities, mutual funds, and GICs.

Specific guidelines regarding allocation of assets are as follows: equities shall comprise between 25% and 75% of the total portfolio, while fixed income shall comprise between 30% and 65%. Investment performance is monitored on a regular basis and investments are re-allocated to stay within specific guidelines. An equity/fixed income allocation of 55%/45% is preferred. The securities of any one company or government agency should not exceed 10% of the total fund, and no more than 20% of the total fund should be invested in any one industry. Individual treasury securities may represent 50% of the total fund, while the total allocation to treasury bonds and notes may represent up to 100% of the Plan's aggregate bond position.

Watts Water Technologies, Inc. and Subsidiaries
Notes to Consolidated Financial Statements (Continued)

(14) Employee Benefit Plans (Continued)

Cash flows:

The information related to the Company's pension funds cash flow is as follows:

	December 31,	
	2008	2007
	(in millions)	
Employer Contributions	\$3.2	\$7.3
Benefit Payments	\$2.5	\$2.3

The Company expects to contribute approximately \$6.0 million in 2009.

Expected benefit payments to be paid by the pension plans are as follows:

	(in millions)
During fiscal year ending December 31, 2009	\$ 2.9
During fiscal year ending December 31, 2010	\$ 3.2
During fiscal year ending December 31, 2011	\$ 3.4
During fiscal year ending December 31, 2012	\$ 3.6
During fiscal year ending December 31, 2013	\$ 4.0
During fiscal year ending December 31, 2014 through December 31, 2018	\$27.7

Additionally, substantially all of the Company's domestic employees are eligible to participate in certain 401(k) savings plans. Under these plans, the Company matches a specified percentage of employee contributions, subject to certain limitations. The Company's match contributions (included in selling, general and administrative expense) for the years ended December 31, 2008, 2007, and 2006 were \$0.6 million in each year, respectively. Charges for European pension plans approximated \$3.3 million, \$3.0 million and \$1.9 million for the years ended December 31, 2008, 2007, and 2006, respectively. These costs relate to plans administered by certain European subsidiaries, with benefits calculated according to government requirements and paid out to employees upon retirement or change of employment.

The Company entered into a Supplemental Compensation Agreement (the Agreement) with Timothy P. Horne on September 1, 1996. Per the Agreement, upon ceasing to be an employee of the Company, Mr. Horne must make himself available, as requested by the Board, to work a minimum of 300 but not more than 500 hours per year as a consultant in return for certain annual compensation as long as he is physically able to do so. If Mr. Horne complies with the consulting provisions of the agreement above, he shall receive supplemental compensation on an annual basis of \$400,000 per year, subject to cost of living increases each year, in exchange for the services performed, as long as he is physically able to do so. In the event of physical disability, subsequent to commencing consulting services for the Company, Mr. Horne will continue to receive \$400,000 annually. The payment for consulting services provided by Mr. Horne will be expensed as incurred by the Company. Mr. Horne retired effective December 31, 2002, and therefore the Supplemental Compensation period began on January 1, 2003. In accordance with Financial Accounting Standards Board Statement No. 106, "Employers Accounting for Post Retirement Benefits Other Than Pensions", the Company will accrue for the future post-retirement disability benefits over the period from January 1, 2003, to the time in which Mr. Horne becomes physically unable to perform his consulting services (the period in which the disability benefits are earned).

Watts Water Technologies, Inc. and Subsidiaries
Notes to Consolidated Financial Statements (Continued)

(15) Contingencies and Environmental Remediation

James Jones Litigation

On June 25, 1997, Nora Armenta (the Relator) filed a civil action in the California Superior Court for Los Angeles County (the Armenta case) against James Jones Company (James Jones), Mueller Co., Tyco International (U.S.), and the Company. The Company formerly owned James Jones. The Relator filed under the qui tam provision of the California state False Claims Act, Cal. Govt. Code § 12650 et seq. (California False Claims Act) and generally alleged that James Jones and the other defendants violated this statute by delivering some “defective” or “non-conforming” waterworks parts to municipal water systems in the State of California. The Relator filed a First Amended Complaint in November 1998 and a Second Amended Complaint in December 2000, which brought the total number of plaintiffs to 161. The Complaint further alleges that purchased non-conforming James Jones waterworks parts may leach into public drinking water elevated amounts of lead that may create a public health risk because they were made out of ‘81 bronze alloy (UNS No. C8440) and contain more lead than the specified and advertised ‘85 bronze alloy (UNS No. C83600). This contention is based on the average difference of about 2% lead content between ‘81 bronze (6% to 8% lead) and ‘85 bronze (4% to 6% lead) and the assumption that this would mean increased consumable lead in public drinking water that could cause a public health concern. The Company believes the evidence and discovery available to date indicates that this is not the case. In addition, ‘81 bronze is used extensively in municipal and home plumbing systems and is approved by municipal, local and national codes. The Federal Environmental Protection Agency also defines metal for pipe fittings with no more than 8% lead as “lead free” under Section 1417 of the Federal Safe Drinking Water Act.

In this case, the Relator seeks three times an unspecified amount of actual damages and alleges that the municipalities have suffered hundreds of millions of dollars in damages. She also seeks civil penalties of \$10,000 for each false claim and alleges that defendants are responsible for tens of thousands of false claims. Finally, the Relator requests an award of costs of this action, including attorneys’ fees.

In December 1998, the Los Angeles Department of Water and Power (LADWP) intervened in this case and filed a complaint. The Company settled with the city of Los Angeles, by far the most significant city, for \$7.3 million plus attorneys’ fees. Co-defendants contributed \$2.0 million toward this settlement.

In August 2003, an additional settlement payment was made for \$13.0 million (\$11.0 million from us and \$2.0 million from James Jones), which settled the claims of the three Phase I cities (Santa Monica, San Francisco and East Bay Municipal Utility District) chosen by the Relator as having the strongest claims to be tried first. In addition to this \$13.0 million payment, the Company was obligated to pay the Relator’s attorney’s fees.

On June 22, 2005, the Court dismissed the claims of the Phase II cities selected for a second trial phase (Contra Costa, Corona, Santa Cruz and Vallejo). The Court ruled that the Relator and these cities were required to show that the cities had received out of specification parts which were related to specific invoices and that this showing had not been made. Although each city’s claim is unique, this ruling is significant for the claims of the remaining cities, and the Relator appealed. On June 29, 2007, the appellate court dismissed this appeal. However, this judgment can be appealed again at the conclusion of the entire case. The trial court has scheduled a trial on October 6, 2009 for six Phase III cities. Litigation is inherently uncertain, and the Company is unable to predict the outcome of this case.

On September 15, 2004, the Relator’s attorneys filed a lawsuit in the California Superior Court for the City of Banning and 42 other cities and water districts against James Jones, Watts and Mueller Co.

Watts Water Technologies, Inc. and Subsidiaries
Notes to Consolidated Financial Statements (Continued)

(15) Contingencies and Environmental Remediation (Continued)

based on the same transactions alleged in the Armenta case alleging common law fraud. In October 2008, the Court dismissed the claims of 11 cities as time-barred. A first phase trial of selected cities is scheduled for April 13, 2010. Litigation is inherently uncertain, and the Company is unable to predict the outcome of this case.

On February 14, 2001, after the Company's insurers had denied coverage for the claims in the Armenta case, the Company filed a complaint for coverage against its insurers in the California Superior Court (the coverage case). James Jones filed a similar complaint, the cases were consolidated, and the trial court made summary adjudication rulings that Zurich must pay all reasonable defense costs incurred by the Company and James Jones in the Armenta case since April 23, 1998 as well as such defense costs in the future until the end of the Armenta case. In August 2004, the California Court of Appeal affirmed these rulings, and, on December 1, 2004, the California Supreme Court denied Zurich's appeal of this decision. This denial permanently established Zurich's obligation to pay Armenta defense costs for both the Company and James Jones, and Zurich is currently making payments of incurred Armenta defense costs. However, as noted below, Zurich asserts that the defense costs paid by it are subject to reimbursement.

On November 22, 2002, the trial court entered a summary adjudication order that Zurich must indemnify and pay the Company and James Jones for amounts paid to settle with the City of Los Angeles. On August 6, 2004, the trial court made another summary adjudication ruling that Zurich must indemnify and pay the Company and James Jones for the \$13.0 million paid to settle the claims of the Phase I cities described above. Zurich will be able to appeal these orders at the end of the coverage case. Zurich has now made all of the payments required by these indemnity orders.

On February 8, 2006, Zurich filed a motion to set aside as void the November 22, 2002 and August 6, 2004 summary adjudication indemnity payment orders. After this motion was denied, Zurich's appeal was also denied and the California Supreme Court denied Zurich's petition for review. The Company is currently unable to predict the finality of these indemnity payment orders since Zurich can also appeal them at the end of the coverage case.

Zurich has asserted that all amounts paid by it to the Company and James Jones are subject to reimbursement under Deductible Agreements related to the insurance policies between Zurich and Watts. The Company believes that the agreements are unenforceable, that the Armenta case should be viewed as one occurrence, and that the deductible amount should be \$0.5 million per occurrence if the agreements are enforceable.

On January 31, 2006, the federal district court in Chicago, Illinois determined that there are disputes under all Deductible Agreements in effect during the period in which Zurich issued primary policies and that the arbitrator could decide which agreements would control reimbursement claims. The Company appealed this ruling. On October 20, 2006, the United States Court of Appeals for the Seventh Circuit affirmed that an arbitration panel could decide which deductible agreements between Zurich and the Company would control Zurich's reimbursement claim.

Based on management's assessment, the Company does not believe that the ultimate outcome of the James Jones Litigation will have a material adverse effect on its liquidity, financial condition or results of operations. While this assessment is based on the facts currently known by the Company, litigation is inherently uncertain, the actual liability to us to resolve this litigation fully cannot be predicted with any certainty and there exists a reasonable possibility that we may ultimately incur losses in the James Jones Litigation in excess of the amount accrued. The Company intends to continue to contest vigorously all aspects of the James Jones Litigation.

Watts Water Technologies, Inc. and Subsidiaries
Notes to Consolidated Financial Statements (Continued)

(15) Contingencies and Environmental Remediation (Continued)

Environmental Remediation

The Company has been named as a potentially responsible party with respect to a limited number of identified contaminated sites. The levels of contamination vary significantly from site to site as do the related levels of remediation efforts. Environmental liabilities are recorded based on the most probable cost, if known, or on the estimated minimum cost of remediation. The Company accrues estimated environmental liabilities based on assumptions, which are subject to a number of factors and uncertainties. Circumstances which can affect the reliability and precision of these estimates include identification of additional sites, environmental regulations, level of cleanup required, technologies available, number and financial condition of other contributors to remediation and the time period over which remediation may occur. The Company recognizes changes in estimates as new remediation requirements are defined or as new information becomes available.

Based on the facts currently known to the Company, it does not believe that the ultimate outcome of these matters will have a material adverse effect on its liquidity, financial condition or results of operations. Some of its environmental matters are inherently uncertain and there exists a possibility that we may ultimately incur losses from these matters in excess of the amount accrued. However, the Company cannot currently estimate the amount of any such additional losses.

Asbestos Litigation

The Company is defending approximately 105 lawsuits in different jurisdictions, with the greatest number filed in Mississippi and California state courts, alleging injury or death as a result of exposure to asbestos. The complaints in these cases typically name a large number of defendants and do not identify any particular Watts products as a source of asbestos exposure. To date, the Company has obtained a dismissal in every case before it has reached trial because discovery has failed to yield evidence of substantial exposure to any Watts products. Based on the facts currently known to the Company, it does not believe that the ultimate outcome of these claims will have a material adverse effect on its liquidity, financial condition or results of operations.

Other Litigation

Other lawsuits and proceedings or claims, arising from the ordinary course of operations, are also pending or threatened against us. Based on the facts currently known to the Company, it does not believe that the ultimate outcome of these other litigation matters will have a material adverse effect on its liquidity, financial condition or results of operations.

(16) Financial Instruments

Fair Value

The carrying amounts of cash and cash equivalents, short-term investments, trade receivables and trade payables approximate fair value because of the short maturity of these financial instruments.

The fair value of the Company's 4.87% senior notes due 2010, 5.47% senior notes due 2013 and 5.85% senior notes due 2016 is based on quoted market prices. The fair value of the Company's

Watts Water Technologies, Inc. and Subsidiaries
Notes to Consolidated Financial Statements (Continued)

(16) Financial Instruments (Continued)

variable rate debt approximates its carrying value. The carrying amount and the estimated fair market value of the Company's long-term debt, including the current portion, are as follows:

	December 31,	
	2008	2007
	(in millions)	
Carrying amount	\$414.3	\$433.5
Estimated fair value	\$339.4	\$424.9

Derivative Instruments

The Company uses foreign currency forward exchange contracts as an economic hedge to reduce the impact of currency fluctuations on certain anticipated intercompany purchase transactions that are expected to occur during the next twelve months and certain other foreign currency transactions. Realized and unrealized gains and losses on the contracts are recognized in other income/expense. These contracts do not subject the Company to significant market risk from exchange movement because they offset gains and losses on the related foreign currency denominated transactions. At December 31, 2008 and 2007, the fair value of the contracts were immaterial.

From time to time, the Company enters into swaps or forwards to limit the volatility associated with the purchase of metals, such as copper. The Company typically structures the terms of these financial instruments to coincide with purchases made throughout the year. During 2008, the Company entered into a series of copper swaps to fix the price per pound for copper from October 2008 through September 2009 for one customer. The Company has determined that these copper swaps do not qualify for hedge accounting and is accounting for these financial instruments as an economic hedge. Therefore, any changes in the fair value of the copper swaps are recorded immediately in the Consolidated Statement of Operations. The Company believes that the use of swap contracts to fix the purchase price of copper allows the Company the ability to provide firm pricing to that one customer. The Company does not enter into swap or forward contracts for speculative purposes. At December 31, 2008, unrealized losses on the copper swaps were \$1.6 million and are included in other income/expense in the Consolidated Statement of Operations.

Watts Water Technologies, Inc. and Subsidiaries
Notes to Consolidated Financial Statements (Continued)

(16) Financial Instruments (Continued)

We measure certain financial assets and liabilities at fair value on a recurring basis, including trading auction rate securities, foreign currency derivatives and metal derivatives. The fair value of these certain financial assets and liabilities was determined using the following inputs at December 31, 2008:

	Fair Value Measurements at Reporting Date Using:			
	Quoted Prices in Active Markets for Identical Assets	Significant Observable Inputs	Significant Unobservable Inputs	
	(Level 1)	(Level 2)	(Level 3)	
	Total	(in millions)		
Assets				
Trading securities(1)	\$ 8.3	\$ —	\$ —	\$8.3
Plan asset for deferred compensation(2) . . .	2.4	2.4	—	—
Total assets	<u>\$10.7</u>	<u>\$2.4</u>	<u>\$ —</u>	<u>\$8.3</u>
Liabilities				
Copper swap(3)	\$ 1.6	\$ —	\$1.6	\$ —
Plan liability for deferred compensation(4) .	2.4	2.4	—	—
Total liabilities	<u>\$ 4.0</u>	<u>\$2.4</u>	<u>\$1.6</u>	<u>\$ —</u>

- (1) Included in long-term investment securities on the Company's consolidated balance sheet.
- (2) Included in other, net on the Company's consolidated balance sheet.
- (3) Included in accrued expenses and other liabilities on the Company's consolidated balance sheet.
- (4) Included in other noncurrent liabilities on the Company's consolidated balance sheet.

The table below provides a summary of the changes in fair value of all financial assets measured at fair value on a recurring basis using significant unobservable inputs (Level 3) for the period December 31, 2007 to December 31, 2008.

	Balance December 31, 2007	Purchases, sales, settlements, net	Total realized and unrealized gains (losses) included in:		Balance December 31, 2008
			Earnings	Comprehensive income	
Trading securities	\$39.0	\$(30.6)	\$(0.1)	\$ —	\$8.3

Trading securities comprise auction rate securities and rights issued by UBS, AG (UBS). The Company holds a variety of interest bearing auction rate securities, or ARS, that includes \$4.8 million in municipal bonds and \$1.2 million in student loans at December 31, 2008. These ARS investments are intended to provide liquidity via an auction process that resets the applicable interest rate at predetermined calendar intervals, allowing investors to either roll over their holdings or sell their interests at par. The recent uncertainties in the credit markets have affected all of the Company's holdings in ARS investments, and auctions for the Company's investments in these securities have failed on their respective auction dates. Consequently, the investments are not currently liquid and the Company will not be able to access these funds until a future auction of these investments is successful or a buyer is found outside of the auction process. Maturity dates for these ARS investments range from 2027 to 2036.

Watts Water Technologies, Inc. and Subsidiaries
Notes to Consolidated Financial Statements (Continued)

(16) Financial Instruments (Continued)

All of the ARS investments were AAA rated investment grade quality and were in compliance with the Company's investment policy at the time of acquisition. The remaining securities are rated AA. During the fourth quarter of 2008, the Company and its broker elected to participate in a settlement offer from UBS for all of the outstanding ARS investments. Under the terms of the settlement offer, the Company and its broker were issued rights by UBS entitling the holder to require UBS to purchase the underlying ARS at par value for the period from June 30, 2010, through July 2, 2012. The rights also entitle UBS to purchase or sell the ARS at any time from the settlement date, in which case UBS would be required to pay par value for the ARS.

Typically the fair value of ARS investments approximates par value due to frequent interest rate resets through the auction process. While the Company continues to earn interest on its ARS investments, these investments are not currently trading and therefore do not currently have a readily determinable market value.

The Company has used a discounted cash flow model to determine the estimated fair value of its investment in ARS and investments in UBS rights as of December 31, 2008. The assumptions used in preparing the discounted cash flow model include estimates for interest rates, credit quality of the ARS issuer, timing and amount of cash flows, government guarantees related to student loans and the expected holding periods of the ARS. Based on this assessment of fair value, as of December 31, 2008, the Company recorded a charge of approximately \$2.4 million to other (income) expense in the Consolidated Statement of Operations for its investment in ARS. The Company performed a valuation of the ARS with the rights from UBS. The Company determined the value of the rights based upon the difference between the ARS without the rights and the ARS with the rights. Based on this assessment of fair value, the Company recorded the investment in rights from UBS of approximately \$2.3 million to other (income) expense.

Cash equivalents consist of instruments with remaining maturities of three months or less at the date of purchase. The remaining balance of cash equivalents consists primarily of money market funds, for which the carrying amount is a reasonable estimate of fair value.

Leases

The Company leases certain manufacturing facilities, sales offices, warehouses, and equipment. Generally, the leases carry renewal provisions and require the Company to pay maintenance costs.

Watts Water Technologies, Inc. and Subsidiaries
Notes to Consolidated Financial Statements (Continued)

(16) Financial Instruments (Continued)

Future minimum lease payments under capital leases and non-cancelable operating leases as of December 31, 2008 are as follows:

	<u>Capital Leases</u>	<u>Operating Leases</u>
	(in millions)	
2009	\$ 1.7	\$ 7.7
2010	1.7	4.7
2011	1.7	3.2
2012	1.6	2.3
2013	1.6	2.0
Thereafter	9.0	6.1
Total	<u>\$17.3</u>	<u>\$26.0</u>
Less amount representing interest (at rates ranging from 4.2% to 8.7%) .	<u>(2.7)</u>	
Present value of net minimum capital lease payments	14.6	
Less current installments of obligations under capital leases	<u>(1.3)</u>	
Obligations under capital leases, excluding installments	<u>\$13.3</u>	

Carrying amounts of assets under capital lease include:

	<u>December 31,</u>	
	<u>2008</u>	<u>2007</u>
	(in millions)	
Buildings	<u>\$17.7</u>	\$18.6
Machinery and equipment	<u>7.8</u>	8.9
	<u>25.5</u>	27.5
Less accumulated depreciation	<u>(4.3)</u>	(4.0)
	<u>\$21.2</u>	<u>\$23.5</u>

(17) Segment Information

Under the criteria set forth in Financial Accounting Standards Board No. 131, "Disclosure about Segments of an Enterprise and Related Information," the Company operates in three geographic segments: North America, Europe, and China. Each of these segments sell similar products, is managed separately and has separate financial results that are reviewed by the Company's chief operating decision-maker. All intercompany sales transactions have been eliminated. Sales by region are based upon location of the entity recording the sale. The accounting policies for each segment are the same as those described in the summary of significant accounting policies (see Note 2).

Watts Water Technologies, Inc. and Subsidiaries
Notes to Consolidated Financial Statements (Continued)

(17) Segment Information (Continued)

The following is a summary of the Company's significant accounts and balances by segment, reconciled to its consolidated totals:

	December 31,		
	2008	2007	2006
	(in millions)		
Net Sales			
North America	\$ 866.2	\$ 871.0	\$ 821.3
Europe	546.0	452.6	367.5
China	47.2	58.7	42.0
Consolidated net sales	<u>\$1,459.4</u>	<u>\$1,382.3</u>	<u>\$1,230.8</u>
Operating income (loss)			
North America	\$ 67.8	\$ 93.3	\$ 98.5
Europe	65.7	53.6	50.0
China	(5.7)	7.9	7.2
Subtotal reportable segments	127.8	154.8	\$ 155.7
Corporate (*)	(27.2)	(29.1)	(25.2)
Consolidated operating income	100.6	125.7	130.5
Interest income	5.1	14.5	5.0
Interest expense	(26.2)	(26.9)	(22.1)
Minority interest	1.9	2.8	1.8
Other	(9.1)	(2.3)	0.9
Income from continuing operations before income taxes	<u>\$ 72.3</u>	<u>\$ 113.8</u>	<u>\$ 116.1</u>
Identifiable Assets			
North America	\$ 821.7	\$1,066.0	\$1,046.8
Europe	716.8	531.6	493.4
China	121.6	131.7	120.7
Consolidated identifiable assets	<u>\$1,660.1</u>	<u>\$1,729.3</u>	<u>\$1,660.9</u>
Long-Lived Assets			
North America	\$ 92.3	\$ 100.2	\$ 99.7
Europe	109.3	88.5	78.4
China	35.8	35.0	28.1
Consolidated long-lived assets	<u>\$ 237.4</u>	<u>\$ 223.7</u>	<u>\$ 206.2</u>
Capital Expenditures			
North America	\$ 8.3	\$ 13.9	\$ 14.6
Europe	13.9	12.6	27.5
China	4.4	11.3	2.6
Consolidated capital expenditures	<u>\$ 26.6</u>	<u>\$ 37.8</u>	<u>\$ 44.7</u>
Depreciation and Amortization			
North America	\$ 18.7	\$ 17.8	\$ 17.1
Europe	21.2	15.7	13.0
China	5.2	5.9	5.2
Consolidated depreciation and amortization	<u>\$ 45.1</u>	<u>\$ 39.4</u>	<u>\$ 35.3</u>

* Corporate expenses are primarily for compensation expense, Sarbanes-Oxley compliance, professional fees, including legal and audit expenses, shareholder services and benefit administration costs. These costs are not allocated to the geographic segments as they are viewed as corporate functions that support all activities.

Watts Water Technologies, Inc. and Subsidiaries
Notes to Consolidated Financial Statements (Continued)

(17) Segment Information (Continued)

The North America segment consists of U.S. net sales of \$798.1 million, \$805.5 million and \$762.7 million for the years ended December 31, 2008, 2007 and 2006, respectively. The North American segment also consists of U.S. long-lived assets of \$86.6 million, \$92.7 million and \$93.1 million as of December 31, 2008, 2007 and 2006, respectively.

Intersegment sales for the year ended December 31, 2008 for North America, Europe and China were \$6.4 million, \$6.4 million and \$133.1 million, respectively. Intersegment sales for the year ended December 31, 2007 for North America, Europe and China were \$6.6 million, \$6.0 million and \$137.1 million, respectively. Intersegment sales for the year ended December 31, 2006 for North America, Europe and China were \$6.9 million, \$3.0 million and \$82.3 million, respectively.

(18) Quarterly Financial Information (unaudited)

	<u>First Quarter</u>	<u>Second Quarter</u>	<u>Third Quarter</u>	<u>Fourth Quarter</u>
	(in millions, except per share information)			
Year ended December 31, 2008				
Net sales	\$344.0	\$389.0	\$379.3	\$347.1
Gross profit	114.4	132.7	123.9	117.4
Income (loss) from continuing operations	13.9	20.0	16.8	(3.4)
Net income (loss)	13.7	19.8	16.7	(3.6)
Per common share:				
Basic				
Income (loss) from continuing operations	0.38	0.55	0.46	(0.09)
Net income (loss)	0.37	0.54	0.46	(0.10)
Diluted				
Income (loss) from continuing operations	0.37	0.54	0.46	(0.09)
Net income (loss)	0.37	0.54	0.45	(0.10)
Dividends per common share				
Year ended December 31, 2007				
Net sales	\$346.1	\$350.4	\$340.5	\$345.3
Gross profit	114.7	114.6	110.4	121.9
Income from continuing operations	20.0	17.7	18.2	21.7
Net income	20.0	17.8	18.1	21.5
Per common share:				
Basic				
Income from continuing operations	0.52	0.46	0.47	0.56
Net income	0.52	0.46	0.47	0.56
Diluted				
Income from continuing operations	0.51	0.45	0.47	0.56
Net income	0.51	0.46	0.46	0.55
Dividends per common share	0.10	0.10	0.10	0.10

Watts Water Technologies, Inc. and Subsidiaries
Notes to Consolidated Financial Statements (Continued)

(19) Subsequent Events

On February 10, 2009, a plan was approved by the Board of Directors to expand the Company's restructuring program to consolidate the Company's manufacturing footprint in North America and China. The plan provides for the closure of three plants, with the relocation of those operations to existing facilities in either North America or China or to a new central facility in the United States.

The footprint consolidation pre-tax charge will be approximately \$11.7 million, including severance charges of approximately \$3.2 million, relocation costs of approximately \$3.3 million and asset write-downs of approximately \$5.2 million. The Company also expects to record a net gain on property sales of \$2.4 million. One-time tax charges of approximately \$7.0 million are also expected to be incurred as part of the building relocations. Approximately 400 positions will be eliminated in connection with this consolidation. The net after tax charge for this manufacturing consolidation program is expected to be approximately \$14.9 million (\$4.4 million non cash), with costs being incurred through December 2009. The Company expects to spend approximately \$4.8 million in capital expenditures to consolidate operations. The Company expects this entire project will be self-funded through net proceeds from the sale of buildings and other assets being disposed of as part of the plan.

On February 9, 2009, the Company declared a quarterly dividend of eleven cents (\$0.11) per share on each outstanding share of Class A Common Stock and Class B Common Stock.

Watts Water Technologies, Inc. and Subsidiaries
Schedule II—Valuation and Qualifying Accounts
(Amounts in millions)

For the Three Years Ended December 31:

	<u>Balance At Beginning of Period</u>	<u>Additions Charged To Expense</u>	<u>Additions Charged To Other Accounts</u>	<u>Deductions</u>	<u>Balance At End of Period</u>
Year Ended December 31, 2006					
Allowance for doubtful accounts	\$ 9.3	3.5	0.3	(2.6)	\$10.5
Allowance for excess and obsolete inventories	\$17.6	9.1	1.0	(7.2)	\$20.5
Year Ended December 31, 2007					
Allowance for doubtful accounts	\$10.5	5.4	1.2	(2.2)	\$14.9
Allowance for excess and obsolete inventories	\$20.5	9.1	2.0	(7.2)	\$24.4
Year Ended December 31, 2008					
Allowance for doubtful accounts	\$14.9	4.7	0.6	(8.0)	\$12.2
Allowance for excess and obsolete inventories	\$24.4	7.7	0.2	(6.0)	\$26.3

(This page has been left blank intentionally.)

EXHIBIT INDEX

Exhibit No.	Description
2.1	Share Purchase Agreement dated as of April 8, 2008 between Blücher Metal A/S and Watts Denmark Holding A/S (18)
3.1	Restated Certificate of Incorporation, as amended (14)
3.2	Amended and Restated By-Laws, as amended (1)
9.1	The Amended and Restated George B. Horne Voting Trust Agreement—1997 dated as of September 14, 1999 (15)
10.1*	Supplemental Compensation Agreement effective as of September 1, 1996 between the Registrant and Timothy P. Horne (9), Amendment No. 1, dated July 25, 2000 (16), and Amendment No. 2 dated October 23, 2002 (3)
10.2*	Form of Indemnification Agreement between the Registrant and certain directors and officers of the Registrant
10.3*	1996 Stock Option Plan, dated October 15, 1996 (10), and First Amendment dated February 28, 2003 (3)
10.4*	Watts Water Technologies, Inc. Pension Plan (amended and restated effective as of January 1, 2006) and First Amendment effective as of January 1, 2008 (22)
10.5	Registration Rights Agreement dated July 25, 1986 (5)
10.6*	Executive Incentive Bonus Plan, as amended and restated as of January 1, 2008 (8)
10.7	Amended and Restated Stock Restriction Agreement dated October 30, 1991 (2), and Amendment dated August 26, 1997 (12)
10.8*	Watts Industries, Inc. 1991 Non-Employee Directors' Nonqualified Stock Option Plan (6), and Amendment No. 1 (9)
10.9*	Watts Industries, Inc. 2003 Non-Employee Directors' Stock Option Plan (3)
10.10	Letter of Credit issued by Fleet National Bank (as successor to BankBoston, N.A.) for the benefit of Zurich-American Insurance Company dated June 25, 1999, as amended January 22, 2001 (17)
10.11*	Watts Water Technologies, Inc. Management Stock Purchase Plan (Amended and Restated as of January 1, 2005), as amended (20)
10.12	Stock Purchase Agreement dated as of June 19, 1996 by and among Mueller Co., Tyco Valves Limited, Watts Investment Company, Tyco International Ltd. and the Registrant (11)
10.13	Note Purchase Agreement dated as of May 15, 2003 between the Registrant and the Purchasers named in Schedule A thereto relating to the Registrant's \$50,000,000 4.87% Senior Notes, Series A, due May 15, 2010 and \$75,000,000 5.47% Senior Notes, Series B, due May 15, 2013 (7)
10.14	Form of 4.87% Senior Note due May 15, 2010 (7)
10.15	Form of 5.47% Senior Note due May 15, 2013 (7)
10.16*	Watts Water Technologies, Inc. 2004 Stock Incentive Plan, as amended (20)
10.17*	Non-Employee Director Compensation Arrangements (1)
10.18*	Watts Water Technologies, Inc. Supplemental Employees Retirement Plan as Amended and Restated Effective May 4, 2004, First Amendment effective March 1, 2005 and Second Amendment effective January 1, 2008 (22)
10.19*	Form of Incentive Stock Option Agreement under the Watts Water Technologies, Inc. 2004 Stock Incentive Plan (19)
10.20*	Form of Non-Qualified Stock Option Agreement under the Watts Water Technologies, Inc. 2004 Stock Incentive Plan (20)
10.21*	Form of Restricted Stock Award Agreement for Employees under the Watts Water Technologies, Inc. 2004 Stock Incentive Plan (Incremental Vesting) (20)
10.22*	Form of Restricted Stock Award Agreement for Employees under the Watts Water Technologies, Inc. 2004 Stock Incentive Plan (Cliff Vesting) (19)
10.23*	Form of Restricted Stock Award Agreement for Non-Employee Directors under the Watts Water Technologies, Inc. 2004 Stock Incentive Plan (19)

Exhibit No.	Description
10.24	Note Purchase Agreement, dated as of April 27, 2006, between the Registrant and the Purchasers named in Schedule A thereto relating to the Registrant's \$225,000,000 5.85% Senior Notes due April 30, 2016 (4)
10.25	Form of 5.85% Senior Note due April 30, 2016 (4)
10.26	Subsidiary Guaranty, dated as of April 27, 2006, in connection with the Registrant's 5.85% Senior Notes due April 30, 2016 executed by the subsidiary guarantors party thereto, including the form of Joinder to Subsidiary Guaranty (4)
10.27	First Amendment, dated as of April 27, 2006, to Note Purchase Agreement dated as of May 15, 2003 among the Registrant and the purchasers named therein (4)
10.28	Amended and Restated Credit Agreement, dated as of April 27, 2006, among the Registrant, certain subsidiaries of the Registrant as Borrowers, Bank of America, N.A., as Administrative Agent, Swing Line Lender and L/C Issuer and the other lenders referred to therein (4)
10.29	Amended and Restated Guaranty, dated as of April 27, 2006, by the Registrant, the Subsidiaries of the Registrant set forth therein and Watts Industries Europe B.V., in favor of Bank of America, N.A. (4)
10.30*	Resignation Agreement dated February 14, 2008 between the Registrant and Paul A. Lacourciere (18)
10.31*	Severance Agreement dated February 16, 2009 between the Registrant and Douglas T. White
11	Statement Regarding Computation of Earnings per Common Share (13)
21	Subsidiaries
23	Consent of KPMG LLP
31.1	Certification of Principal Executive Officer pursuant to Rule 13a-14(a) or Rule 15d-14(a) of the Securities Exchange Act of 1934, as amended
31.2	Certification of Principal Financial Officer pursuant to Rule 13a-14(a) or Rule 15d-14(a) of the Securities Exchange Act of 1934, as amended
32.1	Certification of Principal Executive Officer Pursuant to 18 U.S.C. Section 1350
32.2	Certification of Principal Financial Officer Pursuant to 18 U.S.C. Section 1350

- (1) Incorporated by reference to the Registrant's Current Report on Form 8-K dated February 5, 2007 (File No. 001-11499).
- (2) Incorporated by reference to the Registrant's Current Report on Form 8-K dated November 14, 1991 (File No. 001-11499).
- (3) Incorporated by reference to the Registrant's Annual Report on Form 10-K for the year ended December 31, 2002 (File No. 001-11499).
- (4) Incorporated by reference to the Registrant's Current Report on Form 8-K dated April 27, 2006 (File No. 001-11499).
- (5) Incorporated by reference to the Registrant's Form S-1 (No. 33-6515) as part of the Second Amendment to such Form S-1 dated August 21, 1986.
- (6) Incorporated by reference to Amendment No. 1 to the Registrant's Annual Report on Form 10-K for year ended June 30, 1992 (File No. 001-11499).
- (7) Incorporated by reference to the Registrant's Current Report on Form 8-K dated May 15, 2003 (File No. 001-11499).
- (8) Incorporated by reference to the Registrant's Current Report on Form 8-K dated May 14, 2008 (File No. 001-11499).
- (9) Incorporated by reference to the Registrant's Annual Report on Form 10-K for year ended June 30, 1996 (File No. 001-11499).
- (10) Incorporated by reference to the Registrant's Form S-8 (No. 333-32685) dated August 1, 1997.
- (11) Incorporated by reference to the Registrant's Current Report on Form 8-K dated September 4, 1996 (File No. 001-11499).

- (12) Incorporated by reference to the Registrant's Annual Report on Form 10-K for year ended June 30, 1997 (File No. 001-11499).
 - (13) Incorporated by reference to notes to Consolidated Financial Statements, Note 2 of this Report.
 - (14) Incorporated by reference to the Registrant's Quarterly Report on Form 10-Q for the quarter ended July 3, 2005 (File No. 001-11499).
 - (15) Incorporated by reference to the Registrant's Annual Report on Form 10-K for year ended June 30, 1999 (File No. 001-11499).
 - (16) Incorporated by reference to the Registrant's Quarterly Report on Form 10-Q for quarter ended September 30, 2000 (File No. 001-11499).
 - (17) Incorporated by reference to the Registrant's Annual Report on Form 10-K for the year ended December 31, 2003 (File No. 001-11499).
 - (18) Incorporated by reference to the Registrant's Current Report on Form 8-K dated April 8, 2008 (File No. 001-11499).
 - (19) Incorporated by reference to the Registrant's Quarterly Report on Form 10-Q for the quarter ended September 26, 2004 (File No. 001-11499).
 - (20) Incorporated by reference to the Registrant's Quarterly Report on Form 10-Q for the quarter ended July 1, 2007 (File No. 001-11499).
 - (21) Incorporated by reference to the Registrant's Quarterly Report on Form 10-Q for the quarter ended March 30, 2008 (File No. 001-11499).
 - (22) Incorporated by reference to the Registrant's Annual Report on Form 10-K for the year ended December 31, 2007 (File No. 001-11499).
- * Management contract or compensatory plan or arrangement.

(This page has been left blank intentionally.)

Executive Officers

Patrick S. O'Keefe
Chief Executive Officer,
President and Director

William C. McCartney
Chief Financial Officer
and Treasurer

David J. Coghlan
President of North America
and Asia

J. Dennis Cawte
Group Managing Director,
Europe

Ernest E. Elliot
Executive Vice President of Marketing

Michael P. Flanders
Executive Vice President of
Manufacturing Operations,
North America and Asia

Josh C. Fu
President, Asia

Kenneth R. Lepage
General Counsel and Secretary

Gregory J. Michaud
Executive Vice President
of Human Resources

Taylor K. Robinson
Executive Vice President of
Supply Chain Management

Directors

Robert L. Ayers
Director

Kenneth F. Burnes
Director

Richard J. Cathcart
Director

Timothy P. Horne
Director

Ralph E. Jackson, Jr.
Director

Kenneth J. McAvoy
Director

John K. McGillicuddy
Director

Gordon W. Moran
Non-Executive Chairman of the Board
and Director

Daniel J. Murphy, III
Director

Patrick S. O'Keefe
Chief Executive Officer,
President and Director

Corporate Information

Executive Offices

815 Chestnut Street
North Andover, MA 01845-6098
Tel. (978)688-1811
Fax: (978)688-2976

Registrar and Transfer Agent

Wells Fargo Bank, N.A.
161 N. Concord Exchange
South St. Paul, MN 55075
(800)468-9716

Counsel

WilmerHale
60 State Street
Boston, MA 02109

Auditors

KPMG LLP
99 High Street
Boston, MA 02110

Stock Listing

New York Stock Exchange
Ticker Symbol: WTS

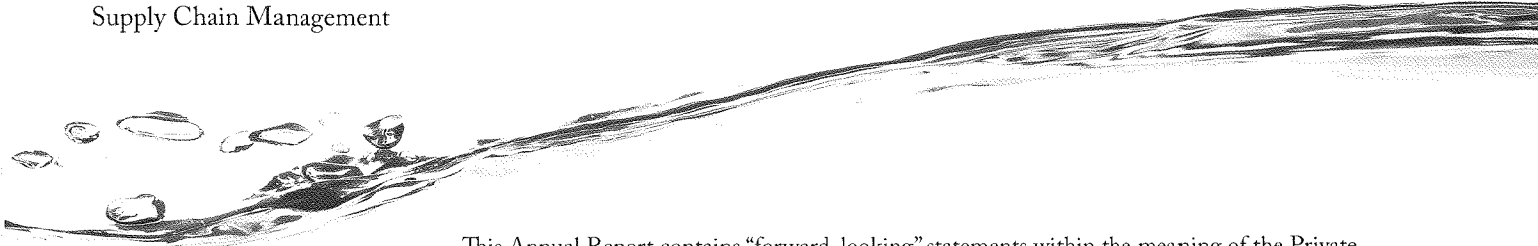

This Annual Report contains “forward-looking” statements within the meaning of the Private Securities Litigation Reform Act of 1995. All statements that relate to prospective events or developments are forward-looking statements. Also, words such as “believe,” “anticipate,” “plan,” “expect,” “will” and similar expressions identify forward-looking statements. We cannot assure investors that our assumptions and expectations will prove to have been correct. There are a number of important factors that could cause our actual results to differ materially from those indicated or implied by forward-looking statements. These factors include, but are not limited to, those set forth in the section entitled “Risk Factors” in our Annual Report on Form 10-K for the year ended December 31, 2008 included in this Annual Report. We undertake no intention or obligation to update or revise any forward-looking statements, whether as a result of new information, future events or otherwise.

For additional information on Watts Water Technologies, Inc., visit our web site at www.wattswater.com

