



05069983

# AutoZone®



PROCESSED

NOV 03 2005

 THOMSON  
FINANCIAL

# '05

 Annual Report

Live the Pledge 

*Selected Financial Data*

Fiscal Year Ended August

(Dollars in millions, except per share data)

	2001 <sup>(1)</sup>	2002	2003	2004	2005
Net Sales	\$4,818	\$5,326	\$5,457	\$5,837	\$5,711
Operating Profit	388	771	918	999	976
Diluted Earnings per Share	1.54	4.00	5.34	6.56	7.18
After-Tax Return on Invested Capital	13.4% <sup>(2)</sup>	19.8%	23.4%	25.1%	23.9%
Domestic Same Store Sales Growth	4%	8%	3%	0%	(2)%
Operating Margin	8.0%	14.5%	16.8%	17.7%	17.1%
Cash Flow from Operations	\$ 467	\$ 736	\$ 721	\$ 638	\$ 648

(1) Fiscal year 2001 includes \$157 million of pre-tax restructuring and impairment charges.

(2) Excludes the impact of the restructuring and impairment charges recorded in fiscal year 2001.

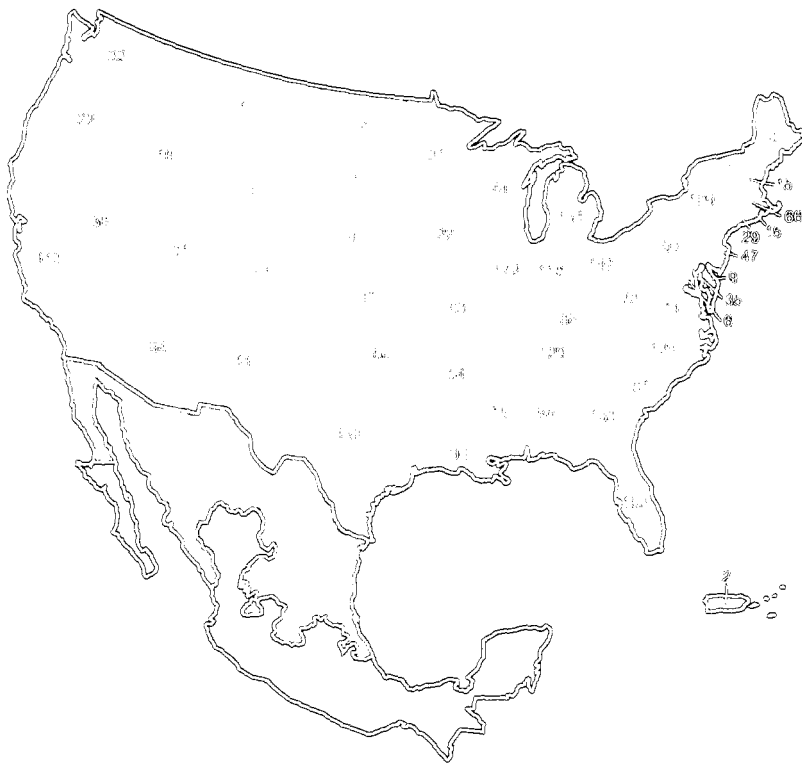

- 3,592 U.S. Stores Across All 48 Continental United States and Puerto Rico
- 81 Mexico Stores Across 11 Mexican States

2005 Sales by Strategic Priority

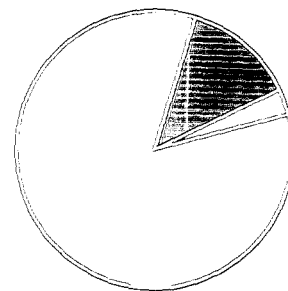

- U.S. Retail - 84%
- Commercial - 13%
- Mexico/Other - 3%

## Dear Customers, AutoZoners, and Stockholders:

We made AutoZone a stronger company in 2005. We continued our string of record earnings and earnings per share since becoming a public company in 1991.

- We invested more than \$280 million to improve our current stores, open 193 new stores, add a new distribution center, and improve our strong technology infrastructure.
- We grew operating cash flows and maintained our investment grade credit rating while using excess cash to repurchase shares.
- We continued to expand the reach of our proprietary brands across categories throughout the store. These key brands, including Valucraft and Duralast, are some of the strongest brands in the automotive aftermarket.
- We repositioned our Commercial business to not only become immediately more profitable but to position it for profitable future growth.
- We opened our 81st store in Mexico, while continuing to expand our reach by opening our first stores in Puerto Rico.
- We launched 2006 by initiating the theme "Live the Pledge." We know winning in this business means providing exceptional customer service and by living our Pledge, we will ensure satisfied customers.

AutoZone has enjoyed a truly amazing history. Our meteoric rise, since our first store in Forrest City, Arkansas in 1979, is due to our incredible AutoZoners and their commitment to customer satisfaction. I often get asked, "What makes AutoZone so different from others? Why have you been so

successful?" While we enjoy many structural advantages, the true answer always comes back to our AutoZoners. We begin every meeting with the AutoZone Cheer, the AutoZone Pledge, and we share Extra Miler stories. These stories are from customers who took the time to share their incredible experiences. It's this dedication to the customer that is at the center of our operating plan for 2006. Our Vision is: Relentlessly create the most exciting Zone for vehicle solutions! Our three strategic priorities remain U.S. Retail, Commercial, and Mexico.

Since being named President and CEO in March, our team has performed a significant assessment of our performance and our practices. While our industry has remained strong, we have not been satisfied with our sales performance over the past several quarters. We conducted extensive research, and our customers confirmed our convictions. Focus on the basics. We must exceed our customers' expectations by leading with trustworthy advice. We must have the right merchandise at the right price, at the right time in order to deepen our relationship with our customers—one transaction at a time. In an environment where our customers' disposable incomes continue to be challenged by historically high gas prices, and competition for those customers exists, we must exceed our customers' expectations. Our focus is to "Live the Pledge."

# 52,000

*All our AutoZoners that help to make this great organization what it is today:  
the number one auto parts and accessories provider across the United States.  
We know that staying on top is about delivering great customer service!*



"AutoZoners always put customers first!

We know our parts and products.

Our stores look great!

We've got the best merchandise at the right price."

Our Pledge clearly articulates our commitments to our customer. As we "Live the Pledge," we remain confident AutoZone will continue to be incredibly successful.

#### *The Environment We See*

Our industry continues to experience stable growth in spite of the near-term macroeconomic challenges. Last year, the Retail or DIY segment, an estimated \$35 billion\* industry, grew at 4%\* while Commercial, an estimated \$48 billion\* industry, grew at an even faster 4.8%\* clip. This marks the 14th consecutive year of steady growth in both of these segments. With the average age of a passenger vehicle on the road being 9.5 years and rising, the need for AutoZone is greater than ever. Additionally, Americans are driving longer distances and own more vehicles per household than ever before. It will be our job well into the future to service their needs.

\*2005/2006 AAIA Factbook

#### *U.S. Retail: Continues to Be Our #1 Priority*

With 3,592 stores in the U.S. at the end of our fiscal year, and an expectation to continue to open new stores at a mid-single digit growth rate, we are firmly committed to servicing all our customers' needs in this, our core business. With an approximate 13%\* market share in this \$35 billion\* industry, we continue to see many years of profitable growth. Our success in the upcoming year will be driven by several initiatives to help our AutoZoners succeed. At the store level, we'll be providing our AutoZoners with significantly more training. We will increase the number of AutoZoners with ASE (Automotive Service Excellence) certifications. Our customers deserve that. We will continue to focus on helping our customers complete the job right, the first time, with the right parts, at the right price! From the store manager to the newest AutoZoner, we're committed to having our AutoZoners have the tools and knowledge necessary to deliver trustworthy advice to every customer. These are the basics and they are what have made us the number one destination for auto parts.

*2005 marked the 26th consecutive year of sales increases for AutoZone. This amazing record has been a team effort. Our focus for 2006 will be to live up to our Pledge. It starts with our customers. Putting our customers first will ensure our continued success.*

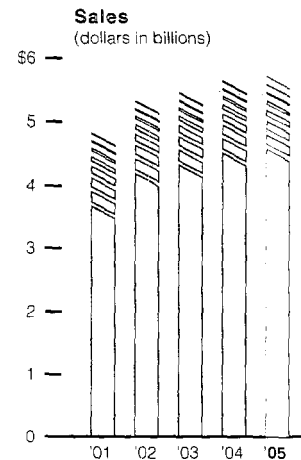

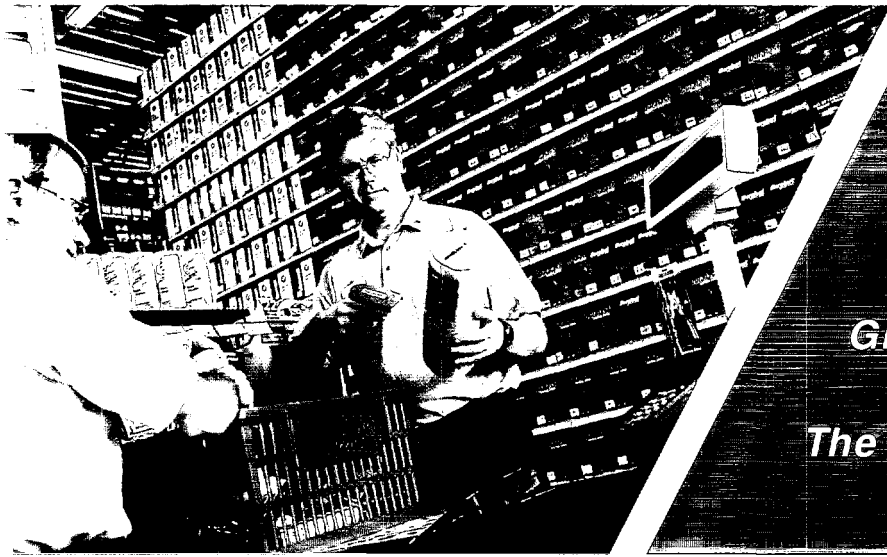

**Customer Service**

**Knowledgeable Employees**

**Great Looking Stores**

**The Best Merchandise**

Our customers have spoken through numerous surveys, and we have listened.

- We will intensely focus on our stores to improve the customer shopping experience by making sure they are properly merchandised and well presented.
- We're also offering an expanded special order network that allows us to offer, on a next-day basis, more than double the number of unique items we previously carried. The initiative, named Project Got It!, more than doubles the available skus to our customers to over 750,000 on a same day or special order basis!
- We are expanding the hours of operations in many of our stores.
- We will make sure our marketing messages are informative and effectively delivered to our targeted audience.

This relentless pursuit of improving the customer experience will also be seen through improvements in store appearance.

*\*2005/2006 AAIA Factbook*

We have purposely reduced the amount of "off-shelf" merchandise placements in our stores to allow a smoother shopping experience. We're continuing our store refresh program and increasing our relocation efforts to meet the changing needs of our customers.

Our goal continues to be to optimize shareholder value. We started four years ago with a Return on Invested Capital (ROIC) of 13%, and I'm proud to say today we have achieved almost 24%, one of the highest in all of retail!

**Commercial: Continued Significant Growth Opportunities**

Commercial, our second strategic priority, is a far newer business for AutoZone than the DIY segment. We've grown the business to roughly \$720 million in just 10 years! Sitting today with only an approximate 1.5%\* market share, we see significant growth opportunities with both the smaller up-and-down-the-street customers and the larger "chain" players. With 2,104 Commercial programs at the end of 2005, we believe we can add to that count while enhancing the relationships we have with our current customers.

# 6 million

*The approximate number of our weekly customers.*

*6,000 The approximate number*

*of ASE certifications our AutoZoners proudly carry. ASE certifications validate the depth of our AutoZoners' knowledge and experience. It assures our customers that we offer trustworthy advice, and we know our parts and products.*

*600 The approximate number of customer thank you notes we receive weekly recognizing our wonderful AutoZoners for going that extra mile to help!*



# F O R T Y

*members of the CEO team leading the charge.*

*Our leadership team is comprised of about 40 talented individuals. It is these executives who work tirelessly to create the AutoZone that exists today. We lead as a team, and we win as a team. Through their continued guidance, the Company is well positioned for a strong future.*

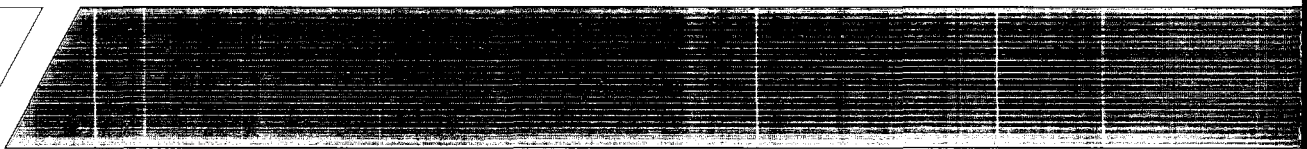



While growth potential is huge, 2005 was a repositioning year for the Commercial business at AutoZone, as we focused on increasing profitability. While this effort had immediate positive effects to the bottom line, it reduced sales. Our management team determined that it was imperative to focus on growing the business profitably, for the long term. We've got a superb team in place to lead this renewed effort, and we've launched new initiatives to jumpstart our sales performance.

At the core of the business for us sits the Commercial Specialist. This AutoZoner handles all the day-to-day orders from our professional customers. In the past six months we've provided the Specialists with new training, technology and marketing tools to go and win the business. Through the use of our new "PDA" handheld devices, our Specialists and Drivers record and time-stamp every phase in a Commercial sale. This new

knowledge allows us to place the right resources when and where they're most in demand. Additionally, we developed and launched a new marketing initiative that offers "the more you buy, the more you save" incentives. We understand this business is won day in and day out at the customer level. Our Commercial Specialists must be trained and motivated appropriately to win the business. While the industry is highly fragmented, with the top three players having only an approximate 17%\* market share, it can be highly competitive. In order for us to win, we will focus on our strengths: national reach, extensive parts availability, speedy delivery service, and industry leading technology—all to provide excellent service.

And, we have ALLDATA. It continues to be the premier provider of automotive diagnostic and repair information to the professional technician. With over 60,000 customers today,

\*2005/2006 AAIA Factbook

# 22

AutoZone is the proud sponsor of the ppc Racing #22 car driven by Kenny Wallace in the NASCAR Busch Series.

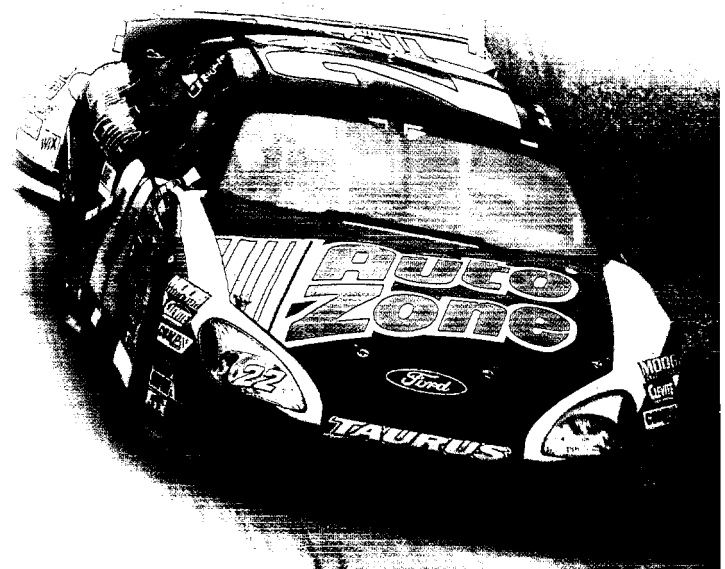

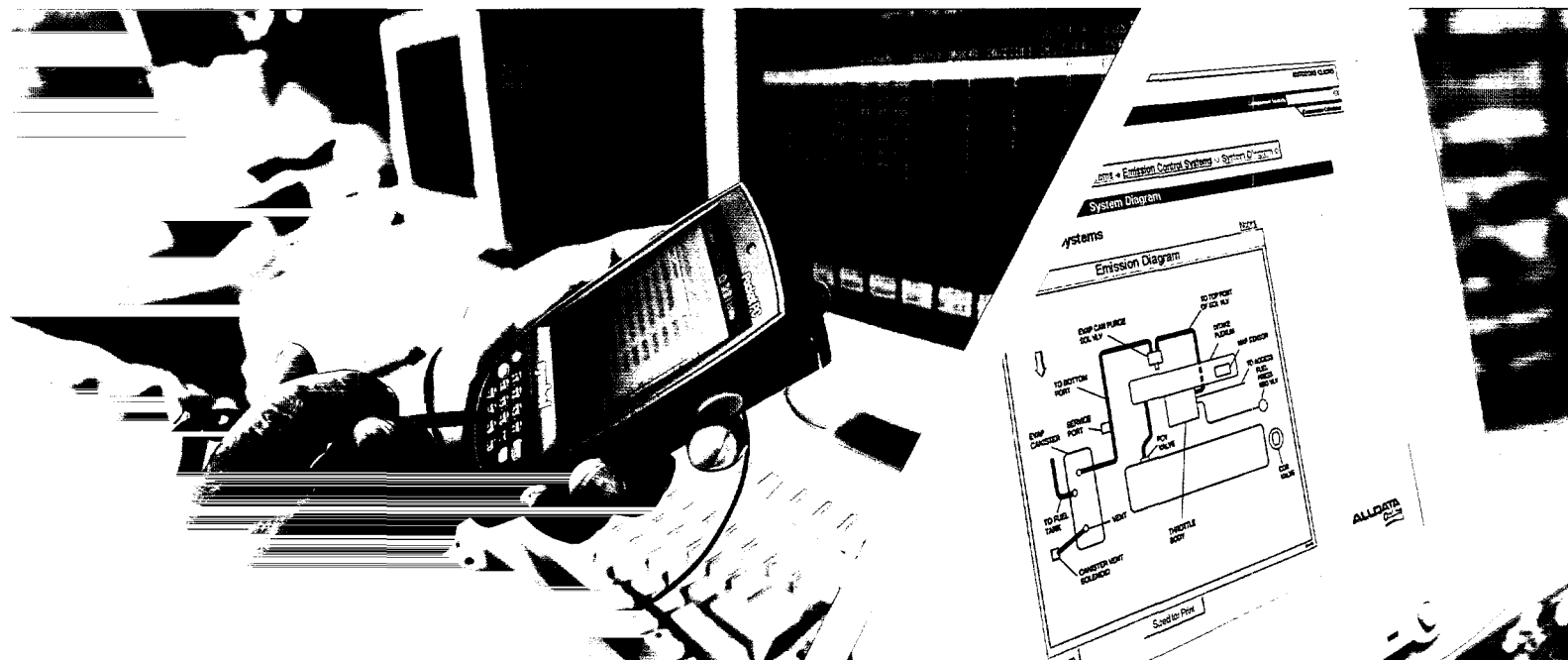

and the continued expansion into a full suite of service products, ALLDATA continues to provide a competitive advantage in the development of this customer base.

With a low startup requirement for capital investment and the ability to leverage our pre-existing stores and distribution system, Commercial will continue to be our second overall priority as it is highly accretive to our ROIC.

#### ***Mexico: Steady Growth, Future Potential***

Our third priority continues to be Mexico. At the end of 2005, we had 81 stores in Mexico being serviced by a distribution center in Nuevo Laredo and a store support center in Monterrey. Mexico represents superb growth opportunities. Our stores in Mexico have customized inventory and are unique to the Mexican automotive landscape as most competition is poorly capitalized and dedicated to very specific lines of products and services.

*AutoZone continues to deliver record EPS growth. However, we cannot simply sit back and expect continued successes. Complacency is not an option. We have to be relentless. Our plan for 2006 is about focusing on the basics. Get the blocking and tackling right, and our customers will continue to generously reward us.*

We will continue to open stores in Mexico, as we expect to celebrate our 100th store opening in 2006.

#### ***The Future***

I can promise you we will continue to be efficient stewards of your capital. We will maintain our financial disciplines and focus only on those initiatives that exceed our after-tax return on invested capital hurdle. This past year, while successful by many companies' standards, we certainly were not satisfied. We will never be satisfied. My first task as the new CEO was to travel extensively, talking to AutoZoners across the Company to hear what they said. I also talked to a tremendous number of customers. We performed broad-scale customer research and came to the conclusion that our future growth doesn't reside with any one new initiative, or any other silver bullets for that matter. Our success has and

**Earnings Per Share**

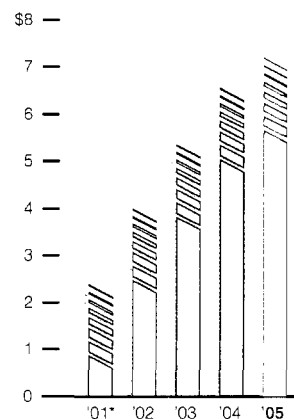

\* Excludes impact from restructuring and impairment charges.





will continue to come from our AutoZoners. What struck me over and over again was the passion they have for our business. When AutoZoners go the extra mile to help the customer, we hear about it. Our customers love to tell us about their great experiences. Our success has been built on exceeding customers' expectations and we are determined to do that by focusing on the basics. We have to make sure we're doing the right things every day to win every customer's business.

In summary, AutoZone continues to be the leader in an exciting and fast growing industry. We have a clear plan for the future and a strong, experienced team to execute it. We are focused on operating AutoZone to exceed our customers' expectations and be the desired place of employment across our industry, all while creating long-term shareholder value.

I would personally like to thank our AutoZoners across the Company for their amazing dedication and commitment to customer satisfaction. Our AutoZoners have an enormous amount of pride in what they do. They are my inspiration! I would also like to thank our CEO Team, comprised of the 40 officers of our Company, for their commitment to providing passionate leadership to all our AutoZoners. They are incredible leaders!

Can we grow this business, and grow it profitably into the future? Yes. AutoZone is well positioned to profitably grow sales. We have a clear plan for the future and a strong team to execute it. I look forward to updating you on our continued success well into the future.



Living the Pledge,

*Bill Rhodes*

**Bill Rhodes**

*President and Chief Executive Officer  
Customer Satisfaction*

# 2005 Financial Highlights

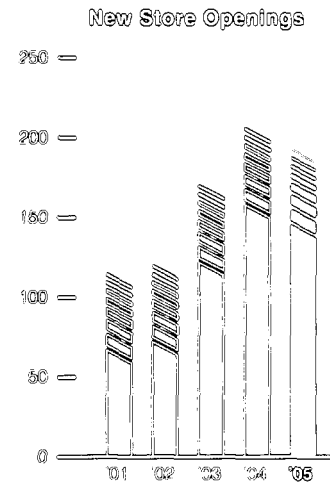
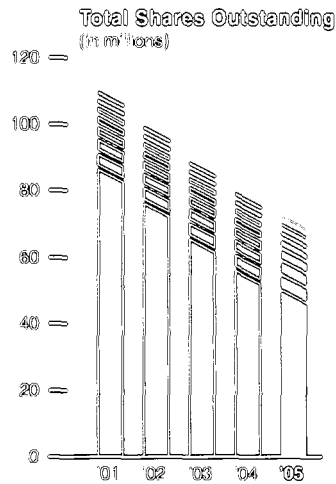
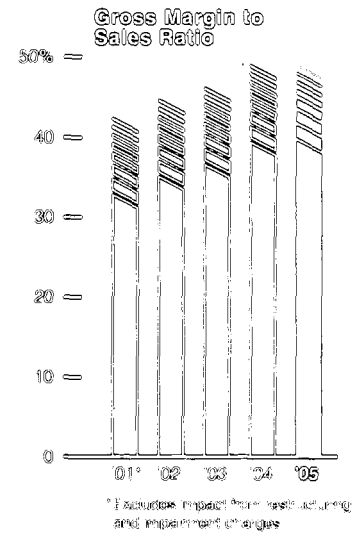
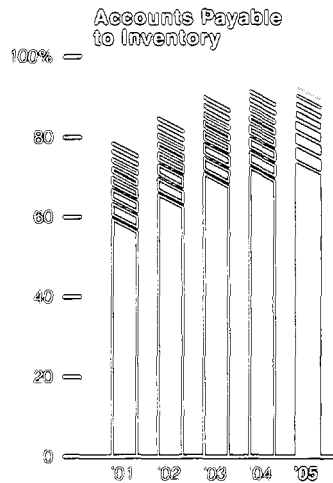
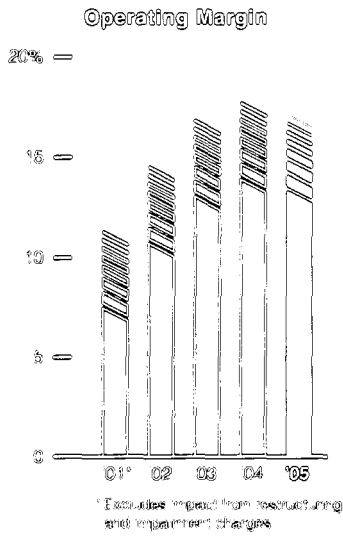
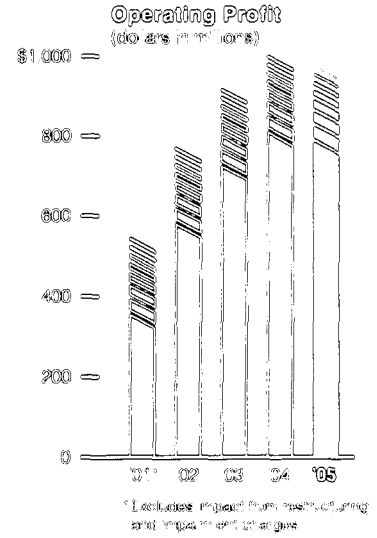
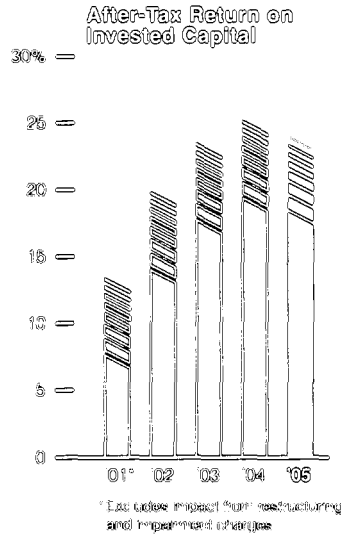

## *Straight Talk on AutoZone's 2005 Financial Performance and Beyond*

### ***What were the highlights of 2005?***

Financial highlights for 2005 include record sales, earnings, and earnings per share.

Regarding our stores, we successfully opened a net 190 new AutoZone locations in 2005, increasing square footage in the mid-single digit range.

Also, we refined our Commercial program during 2005. We closed approximately 100 programs and significantly improved profitability.

We opened 18 new stores in Mexico and look forward to celebrating our 100th store opening in 2006.

### ***Was the Company satisfied with its sales performance in 2005?***

No. We're never satisfied. This past year sales increased primarily due to new store openings. It was the first year we reported negative same store sales growth. We are taking specific steps to address our sales performance. We believe by focusing on improving the customer shopping experience, our customers and sales results will respond positively. Our preliminary tests were favorable, and we rolled specific initiatives, based on these findings, throughout the fourth quarter of 2005. We will focus intensely on profitable sales growth.

### ***What are AutoZone's prospects for 2006?***

Our prospects for the future remain strong! We are intensely focused on ensuring we are meeting our customers' needs profitably. We have either rolled or will roll specific initiatives dedicated to growing both U.S. Retail and Commercial sales. Our theme for 2006 is "Live the Pledge." The AutoZone Pledge was created in the 80's, and everything it stood for then, holds true today. The first line of the Pledge (AutoZoners always put customers first!) is paramount to our success. We understand as we provide a better, more appealing shopping experience, our customers will generously reward us.

### ***What are your financial targets for 2006, and how will you optimize your financial performance?***

Our objectives are no different for this upcoming year than they've been the last several years. We will continue to build long-term shareholder value by improving free cash flow and optimizing our return on invested capital. We do not, nor will we in the future, provide financial guidance. We feel that focusing on achieving published short-term financial goals can be inconsistent with creating longer-term shareholder value.

We continue to see opportunities to improve gross margins, albeit at lower rates than historically, through improved vendor negotiations on cost, distribution center efficiencies, and new importing efforts. Regarding operating expenses, we will continue to test many new initiatives. When we find successful, profitable opportunities, we will implement them. This year, we will increase training, expand hours of operation where appropriate, and continue to ensure we have appropriate staffing levels to provide the service our customers require.

All our efforts are focused on improving the long-term financial returns for the business.

### ***What is AutoZone's debt strategy?***

AutoZone will continue to manage its debt to a targeted credit rating. The metric the Company utilizes is 2.1x EBITDAR (earnings before interest, taxes, depreciation, amortization, and rent) which we believe will continue to provide AutoZone with a strong investment grade rating and appropriate access to capital. Debt is cheaper than equity and therefore, utilizing debt allows AutoZone to lower its overall cost of capital.

### ***Why doesn't AutoZone give earnings guidance?***

We don't give guidance because we're not managing the business to a specific target, as we believe that could actually hinder our results. We will work to deliver our best results every day.

### ***Can you continue to expand your pay-on-scan efforts, and do you still hope to achieve 100% accounts payable to inventory?***

We will continue to use pay-on-scan as one of our tools to manage working capital, as we are quite pleased with the traction we've gained thus far in such a short amount of time. The amount of inventory on pay-on-scan at the end of this past fourth quarter was just under 10% of total merchandise, and has helped to de-risk the business model. It continues to allow us to test new, innovative products with the ability to return those items that do not sell.

Regarding our target of achieving 100% accounts payable to inventory over the next couple of years, that goal has not changed and will not change. This is a very important metric to our management as we feel it substantially de-risks our balance sheet from both foreseeable and unforeseeable events. We will continue to plan around the goal of de-risking our business model. We believe we owe that to our stockholders.

### ***What is your view of the marketplace heading into 2006? Is the consumer being challenged by the historic high prices at the pump?***

While the macro environment is not without its challenges, AutoZone will focus on basic execution in 2006. We feel if we do what it takes to take care of our customers, we can offset much of the impact resulting from higher energy prices. Industry statistics continue to show growth in both the DIY (do-it-yourself) and DIFM (do-it-for-me) industry segments. Consumers have to drive. Our average customer, on the retail side of our business, works on his or her car out of necessity. As fuel prices have increased, it's as important as ever for AutoZone to educate our customers on ways to save money through better fuel efficiency. Our dedication to trustworthy advice has never been as important to our customers. We owe that to every customer every day.

The DIFM customer, while challenged in many of the same ways as our DIY customers, represents a broader opportunity for AutoZone. With only a 1.5% market share, we continue to believe there is a lot of untapped opportunity that will be driven simply by executing more efficiently. We are more confident than ever we've got the right Commercial team in place to drive profitable sales well into the future.

### ***What one thing is AutoZone most concerned about regarding 2006?***

While there are always challenges in business, we are convinced we've put together a plan for 2006 that is solid. We will focus on the right things. We know the number one thing customers demand from us is advice. We've built our entire plan around executing more efficiently at the store level, where customers interact with our AutoZoners. We know our future success is up to us. We are very excited about the upcoming year and continue to appreciate your confidence in us. We are the number one auto parts provider in the United States, and we look forward to growing well into the future.

## Selected Financial Data

(in thousands, except per share data and selected operating data)	Fiscal Year Ended August				
	2005 <sup>(1)</sup>	2004 <sup>(2)</sup>	2003 <sup>(3)</sup>	2002 <sup>(4)</sup>	2001 <sup>(5)</sup>
<b>Income Statement Data</b>					
Net sales	\$5,710,882	\$5,637,025	\$5,457,123	\$5,325,510	\$4,818,185
Cost of sales, including warehouse and delivery expenses	2,918,334	2,880,446	2,942,114	2,950,123	2,804,896
Operating, selling, general and administrative expenses	1,816,884	1,757,873	1,597,212	1,604,379	1,625,598
Operating profit	975,664	998,706	917,797	771,008	387,691
Interest expense—net	102,443	92,804	84,790	79,860	100,665
Income before income taxes	873,221	905,902	833,007	691,148	287,026
Income taxes	302,202	339,700	315,403	263,000	111,500
Net income	\$ 571,019	\$ 566,202	\$ 517,604	\$ 428,148	\$ 175,526
Diluted earnings per share	\$ 7.18	\$ 6.56	\$ 5.34	\$ 4.00	\$ 1.54
Adjusted weighted average shares for diluted earnings per share	79,508	86,350	96,963	107,111	113,801
<b>Balance Sheet Data<sup>(6)</sup></b>					
Current assets	\$1,929,459	\$1,755,757	\$1,671,354	\$1,513,936	\$1,395,240
Working capital (deficit)	118,300	4,706	(40,050)	(45,422)	89,593
Total assets	4,245,257	3,912,565	3,766,826	3,541,599	3,499,241
Current liabilities	1,811,159	1,751,051	1,711,404	1,559,358	1,305,647
Debt	1,861,850	1,869,250	1,546,845	1,194,517	1,225,402
Stockholders' equity	\$ 391,007	\$ 171,393	\$ 373,758	\$ 689,127	\$ 866,213
<b>Selected Operating Data<sup>(11)</sup></b>					
Number of domestic stores at beginning of year	3,420	3,219	3,068	3,019	2,915
New stores	175	202	160	102	107
Replacement stores	7	4	6	15	16
Closed stores	3	1	9	53	3
Net new stores	172	201	151	49	104
Number of domestic stores at end of year	3,592	3,420	3,219	3,068	3,019
Number of Mexico stores at end of year	81	63	49	39	21
Number of total stores at end of year	3,673	3,483	3,268	3,107	3,040
Total domestic store square footage (000s)	22,808	21,689	20,500	19,683	19,377
Average square footage per domestic store	6,350	6,342	6,368	6,416	6,418
Increase in domestic store square footage	5%	6%	4%	2%	4%
Increase (decrease) in domestic comparable store net sales	(2)%	0%	3%	9%	4%
Average net sales per domestic store (000s)	\$ 1,573	\$ 1,647	\$ 1,689	\$ 1,658	\$ 1,543
Average net sales per domestic store square foot	\$ 248	\$ 259	\$ 264	\$ 258	\$ 240
Total domestic employees at end of year	50,869	48,294	47,727	44,179	44,557
Inventory turnover <sup>(7)</sup>	1.81x	1.87x	2.04x	2.25x	2.39x
Net inventory turnover <sup>(8)</sup>	22.76x	20.34x	16.40x	12.51x	10.11x
After-tax return on invested capital <sup>(9)</sup>	23.9%	25.1%	23.4%	19.8%	13.4%
Net cash provided by operating activities	\$ 648,083	\$ 638,379	\$ 720,807	\$ 736,170	\$ 467,300
Cash flow before share repurchases and changes in debt <sup>(10)</sup>	\$ 432,210	\$ 509,447	\$ 561,563	\$ 726,159	\$ 399,312
Return on average equity	203%	208%	97%	55%	19%

(1) Fiscal 2005 operating results include a \$40.3 million pre-tax non-cash charge related to lease accounting, which includes the impact on prior years and reflects additional amortization of leasehold improvements and additional rent expense, and a \$21.3 million income tax benefit from the planned one-time repatriation of earnings from our Mexican operations, and other discrete tax items.

(2) Fiscal 2004 operating results include \$42.1 million in pre-tax gains from warranty negotiations with certain vendors and the change in classification of certain vendor funding to increase operating expenses and decrease cost of sales by \$138.2 million in accordance with Emerging Issues Task Force Issue No. 02-16 ("EITF 02-16") regarding vendor funding, which was adopted during fiscal 2003.

(3) Fiscal 2003 operating results include \$8.7 million in pre-tax gains from warranty negotiations, a \$4.7 million pre-tax gain associated with the settlement of certain liabilities and the repayment of a note associated with the sale of the TruckPro business in December 2001, and a \$4.6 million pre-tax gain as a result of the disposition of properties associated with the 2001 restructuring and impairment charges. Fiscal 2003 was also impacted by the adoption of EITF 02-16, which decreased pre-tax earnings by \$10.0 million, increased operating expenses by \$52.6 million and decreased cost of sales by \$42.6 million.

(4) 53 weeks. Comparable store sales, average net sales per domestic store and average net sales per store square foot for fiscal 2002 have been adjusted to exclude net sales for the 53rd week.

(5) Fiscal 2001 operating results include pre-tax restructuring and impairment charges of \$156.8 million, or \$0.84 per diluted share after tax.

(6) To conform to current year presentation, certain prior year amounts have been adjusted to reflect the impact of reclassifications on the consolidated balance sheet. Prior presentations had included certain long-term obligations within accrued expenses; these amounts have now been reclassified to other non-current liabilities for all periods.

(7) Inventory turnover is calculated as cost of sales divided by the average of the beginning and ending merchandise inventories, which excludes merchandise under pay-on-scan arrangements.

(8) Net inventory turnover is calculated as cost of sales divided by the average of the beginning and ending merchandise inventories, which excludes merchandise under pay-on-scan arrangements, less the average of the beginning and ending accounts payable.

(9) After-tax return on invested capital is calculated as after-tax operating profit (excluding rent and restructuring and impairment charges) divided by average invested capital (which includes a factor to capitalize operating leases). See Reconciliation of Non-GAAP Financial Measures in Management's Discussion and Analysis of Financial Condition and Results of Operations.

(10) Cash flow before share repurchases and changes in debt is calculated as the change in cash and cash equivalents less the change in debt plus treasury stock purchases. See Reconciliation of Non-GAAP Financial Measures in Management's Discussion and Analysis of Financial Condition and Results of Operations.

(11) Selected Operating Data excludes stores related to the TruckPro division that was sold during fiscal 2002.

Quarterly Summary<sup>(1)</sup>  
(unaudited)

	Twelve Weeks Ended			Sixteen Weeks Ended
	November 20, 2004	February 12, 2005 <sup>(2)</sup>	May 7, 2005	August 27, 2005 <sup>(3)</sup>
(in thousands, except per share data)				
Net sales	\$1,286,203	\$1,204,055	\$1,338,387	\$1,882,237
Increase (decrease) in domestic comparable store sales	(3)%	0%	(5)%	(1)%
Gross profit	620,801	582,371	673,103	916,273
Operating profit	216,313	148,719	259,462	351,170
Income before income taxes	194,523	125,074	235,239	318,385
Net income	122,523	94,093	147,789	206,614
Basic earnings per share	1.54	1.18	1.88	2.69
Diluted earnings per share	1.52	1.16	1.86	2.66
(in thousands, except per share data)				
	November 22, 2003 <sup>(4)</sup>	February 14, 2004	May 8, 2004 <sup>(4)</sup>	August 28, 2004 <sup>(4)</sup>
Net sales	\$1,282,040	\$1,159,236	\$1,360,022	\$1,835,727
Increase (decrease) in domestic comparable store sales	2%	0%	2%	(3)%
Gross profit	613,090	564,311	676,187	902,991
Operating profit	215,105	168,526	251,321	363,754
Income before income taxes	194,845	146,604	229,411	335,042
Net income	121,745	91,654	143,411	209,392
Basic earnings per share	1.37	1.06	1.71	2.56
Diluted earnings per share	1.35	1.04	1.68	2.53

(1) The sum of quarterly amounts may not equal the annual amounts reported due to rounding and due to per share amounts being computed independently for each quarter while the full year is based on the annual weighted average shares outstanding.

(2) The second quarter of fiscal 2005 includes a \$40.3 million pre-tax non-cash charge related to lease accounting, which includes the impact on prior years, and reflects additional amortization of leasehold improvements and additional rent expense. The second quarter of fiscal 2005 also includes a \$15.3 million income tax benefit primarily from the planned one-time repatriation of earnings from foreign subsidiaries.

(3) The fourth quarter of fiscal 2005 reflects the income tax benefit of \$6.0 million in discrete income tax items.

(4) The first, third and fourth quarters of fiscal 2004 include \$16.0 million, \$10.6 million, and \$15.5 million, respectively, in pre-tax gains from warranty negotiations with certain vendors.

We are the nation's leading specialty retailer of automotive parts and accessories, with most of our sales to do-it-yourself ("DIY") customers. We began operations in 1979 and as of August 27, 2005, operated 3,592 stores in the United States, including 2 in Puerto Rico, and 81 in Mexico. Each of our stores carries an extensive product line for cars, sport utility vehicles, vans and light trucks, including new and remanufactured automotive hard parts, maintenance items, accessories and non-automotive products. In many of our stores we also have a commercial sales program that provides commercial credit and prompt delivery of parts and other products to local, regional and national repair garages, dealers and service stations. We also sell the ALLDATA brand automotive diagnostic and repair software. On the web, we sell diagnostic and repair information and automotive hard parts, maintenance items, accessories, and non-automotive products through [www.autozone.com](http://www.autozone.com). We do not derive revenue from automotive repair or installation.

## **Results of Operations**

### ***Fiscal 2005 Compared with Fiscal 2004***

For the year ended August 27, 2005, AutoZone reported sales of \$5.711 billion compared with \$5.637 billion for the year ended August 28, 2004, a 1.3% increase from fiscal 2004. This growth was primarily driven by an increase in the number of open stores. At August 27, 2005, we operated 3,592 domestic stores and 81 in Mexico, compared with 3,420 domestic stores and 63 in Mexico at August 28, 2004. Retail DIY sales increased 1.4% and commercial sales decreased 3.0% from prior year. Same store sales, or sales for domestic stores open at least one year, decreased 2% from the prior year. ALLDATA and Mexico sales increased over prior year, contributing 0.5 percentage points of the total increase. While our average ticket increased over prior year, the number of transactions with both our DIY and commercial customers declined from the prior year.

Gross profit for fiscal 2005 was \$2.793 billion, or 48.9% of net sales, compared with \$2.757 billion, or 48.9% of net sales, for fiscal 2004. Fiscal 2005 benefited from \$1.7 million in gains from warranty negotiations as compared to \$42.1 million in warranty gains during fiscal 2004. Offsetting the decline in warranty gains, management continued to improve gross profit margin through merchandising initiatives such as product cost negotiations and changes in product mix.

Operating, selling, general and administrative expenses for fiscal 2005 increased to \$1.817 billion, or 31.8% of net sales, from \$1.758 billion, or 31.2% of net sales for fiscal 2004. This increase is primarily related to the \$40.3 million adjustment, or 0.7% of net sales, related to accounting for leases (see "Note J—Leases" in the accompanying Notes to Consolidated Financial Statements).

Interest expense, net for fiscal 2005 was \$102.4 million compared with \$92.8 million during fiscal 2004. This increase was due to higher average borrowing levels and rates. Average borrowings for fiscal 2005 were \$1.970 billion, compared with \$1.787 billion for fiscal 2004. Weighted average borrowing rates were 5.2% at August 27, 2005, compared to 4.6% at August 28, 2004. The increase in interest rates reflects both the ongoing effort to extend the terms of our borrowings, as well as the impact from increased short-term rates.

Our effective income tax rate declined to 34.6% of pre-tax income for fiscal 2005 as compared to 37.5% for fiscal 2004. The current year effective rate reflects \$21.3 million in one-time tax benefits related to the planned repatriation of earnings from our Mexican operations as a result of the American Jobs Creation Act of 2004, and other discrete income tax items.

Net income for fiscal 2005 increased by 0.9% to \$571.0 million, and diluted earnings per share increased by 9.5% to \$7.18 from \$6.56 in fiscal 2004. The impact of the fiscal 2005 stock repurchases on diluted earnings per share in fiscal 2005 was an increase of approximately \$0.10.

### ***Fiscal 2004 Compared with Fiscal 2003***

For the year ended August 28, 2004, AutoZone reported sales of \$5.637 billion compared with \$5.457 billion for the year ended August 30, 2003, a 3.3% increase from fiscal 2003. This growth was driven by an increase in open stores and continued growth in our commercial sales program. At August 28, 2004, we operated 3,420 domestic stores and 63 in Mexico, compared with 3,219 domestic stores and 49 in Mexico at August 30, 2003. Retail DIY sales increased 1.9% and commercial sales increased 10.5% over prior year. Same store sales, or sales for domestic stores open at least one year, were flat during the year. ALLDATA and Mexico sales increased over prior year, contributing 0.4 percentage points of the total increase. Same store sales for domestic stores increased by 2% for the first three fiscal quarters, but were flat for the year due to a 3% decline during the fourth quarter. While our average ticket increased over prior year, the number of transactions with both our DIY and commercial customers deteriorated during the latter part of the year.

Gross profit for fiscal 2004 was \$2.757 billion, or 48.9% of net sales, compared with \$2.515 billion, or 46.1% of net sales, for fiscal 2003. Fiscal 2004 benefited from \$42.1 million in gains from warranty negotiations as compared to \$8.7 million in warranty gains during fiscal 2003. Further benefiting gross profit was the adoption of Emerging Issues Task Force Issue No. 02-16 ("EITF 02-16") during fiscal 2003, which requires vendor funding to be classified as a reduction to cost of sales. Prior to the adoption of EITF 02-16, vendor funding was reflected as a reduction to operating, selling, general and administrative expenses. The adoption of EITF 02-16 increased gross profit by \$138.2 million in fiscal 2004 and \$42.6 million in fiscal 2003; and increased operating, selling, general and administrative expenses by \$138.2 million in fiscal 2004 and \$52.6 million in fiscal 2003. The remaining improvement in gross profit was driven by strategic pricing and change in product mix.

Operating, selling, general and administrative expenses for fiscal 2004 increased to \$1.758 billion, or 31.2% of net sales, from \$1.597 billion, or 29.3% of net sales for fiscal 2003. Fiscal 2003 benefited from a \$4.7 million pre-tax gain associated with the settlement of certain liabilities and the repayment of a note associated with the sale of the TruckPro business in December 2001, and a \$4.6 million pre-tax gain as a result of the disposition of properties associated with the 2001 restructuring and impairment charges. Drivers of current year expenses included the impact of EITF 02-16, the increase in the number of store refreshes and an increase in new store openings.

Interest expense, net for fiscal 2004 was \$92.8 million compared with \$84.8 million during fiscal 2003. This increase was primarily due to higher average borrowing levels over fiscal 2003. Average borrowings for fiscal 2004 were \$1.787 billion, compared with \$1.485 billion for fiscal 2003. Weighted average borrowing rates were 4.6% at August 28, 2004, compared to 4.4% at August 30, 2003.

Our effective income tax rate declined to 37.5% of pre-tax income for fiscal 2004 as compared to 37.9% for fiscal 2003.

Net income for fiscal 2004 increased by 9.4% to \$566.2 million, and diluted earnings per share increased by 22.8% to \$6.56 from \$5.34 in fiscal 2003. The impact of the fiscal 2004 stock repurchases on diluted earnings per share in fiscal 2004 was an increase of approximately \$0.20.

### **Seasonality and Quarterly Periods**

AutoZone's business is somewhat seasonal in nature, with the highest sales occurring in the summer months of June through August, in which average weekly per-store sales historically have been about 15% to 25% higher than in the slower months of December through February. During short periods of time, a store's sales can be affected by weather conditions. Extremely hot or extremely cold weather may enhance sales by causing parts to fail and spurring sales of seasonal products. Mild or rainy weather tends to soften sales as parts failure rates are lower in mild weather and elective maintenance is deferred during periods of rainy weather. Over the longer term, the effects of weather balance out, as we have stores throughout the United States.

Each of the first three quarters of AutoZone's fiscal year consists of 12 weeks, and the fourth quarter consists of 16 weeks (17 weeks in fiscal 2002). Because the fourth quarter contains the seasonally high sales volume and consists of 16 weeks (17 weeks in fiscal 2002), compared with 12 weeks for each of the first three quarters, our fourth quarter represents a disproportionate share of the annual net sales and net income. The fourth quarter of fiscal 2005 represented 33.0% of annual sales and 36.2% of net income; the fourth quarter of fiscal 2004 represented 32.6% of annual sales and 37.0% of net income; and the fourth quarter of fiscal 2003 represented 33.5% of annual net sales and 40.1% of net income.

### **Liquidity and Capital Resources**

Net cash provided by operating activities was \$648.1 million in fiscal 2005, \$638.4 million in fiscal 2004, and \$720.8 million in fiscal 2003. The primary source of our liquidity is our cash flows realized through the sale of automotive parts and accessories. Our new store development program requires working capital, predominantly for inventories. During the past three fiscal years, we have improved our accounts payable to inventory ratio to 93% at August 27, 2005 from 92% at August 28, 2004, and 90% at August 30, 2003. Contributing to this improvement has been the year-over-year increase in vendor payables as a result of our ability to extend payment terms with our vendors. The increase in merchandise inventories, required to support new store development and sales growth, has largely been financed by our vendors, as evidenced by the higher accounts payable to inventory ratio. Contributing to this improvement is the use of pay-on-scan ("POS") arrangements with certain vendors. Under a POS arrangement, AutoZone will not purchase merchandise supplied by a vendor until that merchandise is ultimately sold to AutoZone's customers. Upon the sale of the merchandise to AutoZone's customers, AutoZone recognizes the liability for the goods and pays the vendor in accordance with the agreed-upon terms. Revenues under POS arrangements are included in net sales in the income statement. Since we do not own merchandise under POS arrangements until just before it is sold to a customer, such merchandise is not included in our balance sheet. AutoZone has financed the repurchase of existing merchandise inventory by certain vendors in order to convert such vendors to POS arrangements. These receivables have durations up to 25 months and approximated \$49.9 million at August 27, 2005. The \$37.5 million current portion of these receivables is reflected in accounts receivable and the \$12.4 million long-term portion is reflected as a component of other long-term assets. Merchandise under POS arrangements was \$151.7 million at August 27, 2005.

AutoZone's primary capital requirement has been the funding of its continued new store development program. From the beginning of fiscal 2003 to August 27, 2005, we have opened 566 net new stores. Net cash flows used in investing activities were \$282.8 million in fiscal 2005, compared to \$193.7 million in fiscal 2004, and \$167.8 million in fiscal 2003. We invested \$283.5 million in capital assets in fiscal 2005 compared to \$184.9 million in fiscal 2004, and \$182.2 million in fiscal 2003. New store openings were 193 for fiscal 2005, 216 for fiscal 2004, and 170 for fiscal 2003. Capital is also invested in the acquisition of certain assets from regional auto parts retailers. During fiscal 2005, four stores were acquired for \$3.1 million and during fiscal 2004, twelve stores were acquired for \$11.4 million. All stores have been converted and are included in our domestic store count upon opening as an AutoZone store. Proceeds from capital asset disposals totaled \$3.8 million in fiscal 2005, \$2.6 million for fiscal 2004, and \$14.4 million for fiscal 2003.

Net cash used in financing activities was \$367.4 million in fiscal 2005, \$460.9 million in fiscal 2004, and \$530.2 million in fiscal 2003. The net cash used in financing activities is primarily attributable to purchases of treasury stock which totaled \$426.9 million for fiscal 2005, \$848.1 million for fiscal 2004, and \$891.1 million for fiscal 2003. Net proceeds from the issuance of debt securities, including repayments on other debt and the net change in commercial paper borrowings, offset the increased level of treasury stock purchases by approximately \$322.4 million in fiscal 2004, and by \$329.8 million in fiscal 2003. The treasury stock purchases in fiscal 2005 were funded by cash flow from operations and not funded by a net increase in debt levels.

We expect to invest in our business consistent with historical rates during fiscal 2006, primarily related to our new store development program and enhancements to existing stores and systems. In addition to the building and land costs, our new store development program requires working capital, predominantly for non-POS inventories. Historically, we have negotiated extended payment terms from suppliers, reducing the working capital required by expansion. We believe that we will be able to continue to finance much of our inventory requirements through favorable payment terms from suppliers.

Depending on the timing and magnitude of our future investments (either in the form of leased or purchased properties or acquisitions), we anticipate that we will rely primarily on internally generated funds and available borrowing capacity to support a majority of our capital expenditures, working capital requirements and stock repurchases. The balance may be funded through new borrowings. We anticipate that we will be able to obtain such financing in view of our credit rating and favorable experiences in the debt markets in the past.

#### *Credit Ratings*

At August 27, 2005, AutoZone had a senior unsecured debt credit rating from Standard & Poor's of BBB+ and a commercial paper rating of A-2. Moody's Investors Service had assigned us a senior unsecured debt credit rating of Baa2 and a commercial paper rating of P-2. As of August 27, 2005, Moody's and Standard & Poor's had AutoZone listed as having a "negative" and "stable" outlook, respectively. If our credit ratings drop, our interest expense may increase; similarly, we anticipate that our interest expense may decrease if our investment ratings are raised. If our commercial paper ratings drop below current levels, we may have difficulty continuing to utilize the commercial paper market and our interest expense will increase, as we will then be required to access more expensive bank lines of credit. If our senior unsecured debt ratings drop below investment grade, our access to financing may become more limited.

#### *Debt Facilities*

We maintain \$1.0 billion of revolving credit facilities with a group of banks. On May 3, 2005, the expiration dates of the facilities were extended by one year as permitted under the original agreement. Of the \$1.0 billion, \$300 million now expires in May 2006 and \$700 million now expires in May 2010. The credit facilities exist primarily to support commercial paper borrowings, letters of credit and other short-term unsecured bank loans. No amounts have been borrowed against the facilities, but as the available balance is reduced by commercial paper borrowings and certain outstanding letters of credit, we had \$661.2 million in available capacity under these facilities at August 27, 2005. The rate of interest payable under the credit facilities is a function of the London Interbank Offered Rate ("LIBOR"), the lending bank's base rate (as defined in the facility agreements) or a competitive bid rate at the option of the Company.

On August 17, 2004, we filed a shelf registration with the Securities and Exchange Commission that allows us to sell up to \$300 million in debt securities to fund general corporate purposes, including repaying, redeeming or repurchasing outstanding debt, and for working capital, capital expenditures, new store openings, stock repurchases and acquisitions. Based on changing market conditions, we chose to delay our issuance of debt securities and settled an outstanding forward-starting interest rate swap during November 2004.

On December 23, 2004, we entered into a credit agreement for a \$300 million, five-year term loan with a group of banks. The term loan consists of, at our election, base rate loans, Eurodollar loans or a combination thereof. Interest accrues on base rate loans at a base rate per annum equal to the higher of prime rate or the Federal Funds Rate plus 1/2 of 1%. Interest accrues on Eurodollar loans at a defined Eurodollar rate plus the applicable percentage, which can range from 40 basis points to 112.5 basis points, depending upon our senior unsecured (non-credit enhanced) long-term debt rating. At our current ratings, the applicable percentage on Eurodollar loans is 50 basis points. On December 30, 2004, the full principal amount of \$300 million was funded as a Eurodollar loan. We may select interest periods of one, two, three or six months for Eurodollar loans, subject to availability. Interest is payable at the end of the selected interest period, but no less frequently than quarterly. We entered into an interest rate swap agreement on December 29, 2004, to effectively fix, based on current debt ratings, the interest rate of the term loan at 4.55%. We have the option to extend loans into subsequent interest period(s) or convert them into loans of another interest rate type. The entire unpaid principal amount of the term loan will be due and payable in full on December 23, 2009, when the facility terminates. We may prepay the term loan in whole or in part at any time without penalty, subject to reimbursement of the lenders' breakage and redeployment costs in the case of prepayment of Eurodollar borrowings.



We agreed to observe certain covenants under the terms of our borrowing agreements, including limitations on total indebtedness, restrictions on liens and minimum fixed charge coverage. All of the repayment obligations under our borrowing agreements may be accelerated and come due prior to the scheduled payment date if covenants are breached or an event of default occurs. Additionally, the repayment obligations may be accelerated if there is a change in control (as defined in the agreements) of AutoZone or its Board of Directors. As of August 27, 2005, we were in compliance with all covenants and expect to remain in compliance with all covenants.

#### Stock Repurchases

As of August 27, 2005, the Board of Directors had authorized the Company to repurchase up to \$4.4 billion of common stock in the open market. Such authorization includes the additional \$500 million that was approved by the Board of Directors on March 16, 2005. From January 1998 to August 27, 2005, the Company has repurchased a total of 87.0 million shares at an aggregate cost of \$4.1 billion. The Company repurchased 4.8 million shares of its common stock at an aggregate cost of \$426.9 million during fiscal 2005, 10.2 million shares of its common stock at an aggregate cost of \$848.1 million during fiscal 2004, and 12.3 million shares of its common stock at an aggregate cost of \$891.1 million during fiscal 2003.

#### Financial Commitments

The following table shows AutoZone's significant contractual obligations as of August 27, 2005:

(in thousands)	Total Contractual Obligations	Payment Due by Period			
		Less than 1 year	Between 1-3 years	Between 4-5 years	Over 5 years
Long-term debt <sup>(1)</sup>	\$1,861,850	\$370,450	\$191,400	\$300,000	\$1,000,000
Interest payments <sup>(2)</sup>	524,589	90,454	156,752	111,571	165,812
Operating leases <sup>(3)</sup>	967,325	141,169	233,874	156,989	435,293
Construction obligations	47,870	47,870	—	—	—
	<u>\$3,401,634</u>	<u>\$649,943</u>	<u>\$582,026</u>	<u>\$568,560</u>	<u>\$1,601,105</u>

(1) Long-term debt balances represent principal maturities, excluding interest. At August 27, 2005, debt balances due in less than one year of \$370.5 million are classified as long-term in our consolidated financial statements, as we have the ability and intention to refinance them on a long-term basis.

(2) Represents obligations for interest payments on long-term debt, including the effect of interest rate hedges.

(3) Operating lease obligations include related interest and are inclusive of amounts accrued within deferred rent and closed store obligations reflected in our consolidated balance sheets.

We have other obligations reflected in our balance sheet that are not reflected in the table above due to the absence of scheduled maturities. Therefore, the timing of these payments cannot be determined, except for amounts estimated to be payable in 2006 that are included in current liabilities. The estimated long-term portions of these financial commitments that are reflected in our consolidated balance sheets are as follows:

(in thousands)	Year Ended August 27, 2005
Self-insurance	\$73,438
Pension	61,407

We have certain contingent liabilities that are not accrued in our balance sheet in accordance with accounting principles generally accepted in the United States. These contingent liabilities are not included in the table above.

#### Off-Balance Sheet Arrangements

The following table reflects the outstanding letters of credit and surety bonds as of August 27, 2005.

(in thousands)	Total Other Commitments
Standby letters of credit	\$121,201
Surety bonds	13,360
	<u>\$134,561</u>

A substantial portion of the outstanding standby letters of credit (which are primarily renewed on an annual basis) and surety bonds are used to cover reimbursement obligations to our workers' compensation carriers. There are no additional contingent liabilities associated with them as the underlying liabilities are already reflected in our balance sheet. The letters of credit and surety bonds arrangements expire within one year, but have automatic renewal clauses.

In conjunction with our commercial sales program, we offer credit to some of our commercial customers. The receivables related to the credit program are sold to a third party at a discount for cash with limited recourse. AutoZone has recorded a reserve for this recourse. At August 27, 2005, the receivables facility had an outstanding balance of \$50.7 million and the balance of the recourse reserve was \$0.5 million.

We have entered into POS arrangements with certain vendors, whereby we will not purchase merchandise supplied by a vendor until just before that merchandise is ultimately sold to our customers. Title and certain risks of ownership remain with the vendor until the merchandise is sold to our customers. Since we do not own merchandise under POS arrangements until just before it is sold to a customer, such merchandise is not recorded on our balance sheet. Upon the sale of the merchandise to our customers, we recognize the liability for the goods and pay the vendor in accordance with the agreed-upon terms. Although we do not hold title to the goods, we do control pricing and have credit collection risk and therefore, gross revenues under POS arrangements are included in net sales in the income statement. Sales of merchandise under POS arrangements approximated \$460.0 million in fiscal 2005 and \$160.0 million in fiscal 2004. There were no sales of POS merchandise in fiscal 2003. Merchandise under POS arrangements was \$151.7 million at August 27, 2005, and \$146.6 million at August 28, 2004.

**Value of Pension Assets**

At August 27, 2005, the fair market value of AutoZone's pension assets was \$107.6 million, and the related accumulated benefit obligation was \$176.3 million. On January 1, 2003, our defined benefit pension plans were frozen. Accordingly, plan participants earn no new benefits under the plan formulas, and no new participants may join the plans. The material assumptions for fiscal 2005 are an expected long-term rate of return on plan assets of 8.0% and a discount rate of 5.25%. For additional information regarding AutoZone's qualified and non-qualified pension plans refer to "Note I—Pensions and Savings Plans" in the accompanying Notes to Consolidated Financial Statements.

**Recent Accounting Pronouncements**

During December 2004, the Financial Accounting Standards Board ("FASB") issued SFAS 123(R), "Share-Based Payment," which requires companies to measure and recognize compensation expense for all stock-based payments at fair value. Stock-based payments include stock option grants and certain transactions under other Company stock plans. AutoZone grants options to purchase common stock to some of its employees and directors under various plans at prices equal to the market value of the stock on the dates the options were granted. Non-employee directors receive at least a portion of their fees in common stock or deferred in units with values equivalent to the value of shares of common stock as of the grant date. Additionally, employees are allowed to purchase our stock at a discount under various employee stock purchase plans. SFAS 123(R) is effective for all fiscal years beginning after June 15, 2005. We plan to adopt this pronouncement on August 28, 2005, which is the beginning of our next fiscal year, using the modified prospective method. As permitted by SFAS 123, we currently account for share-based payments to employees using APB 25's intrinsic value method and, as such, generally recognize no compensation cost for employee stock options. Accordingly, the adoption of SFAS 123(R)'s fair value method will have an impact on our results of operations, but will not have an impact on our overall financial position. The impact of adoption of SFAS 123(R) cannot be predicted at this time because it will depend on, among other things, levels of share-based payments granted in the future and the market value of our common stock. However, had we adopted SFAS 123(R) in prior periods, the impact of that standard would have approximated the impact of SFAS 123 as described in the disclosure of pro forma net income and earnings per share in "Note A—Significant Accounting Policies, Stock Options." SFAS 123(R) also requires the benefits of tax deductions in excess of recognized compensation cost to be reported as a financing cash flow, rather than as an operating cash flow as required under current literature. This requirement will reduce net operating cash flows and increase net financing cash flows in periods after adoption. While the Company cannot estimate what those amounts will be in the future (because they depend on, among other things, when employees exercise stock options), the amount of operating cash flows recognized in the accompanying consolidated statement of cash flows for such excess tax deductions were \$31.8 million in the current year and \$24.3 million in the prior year.

**Critical Accounting Policies***Litigation and Other Contingent Liabilities*

We have received claims related to and been notified that we are a defendant in a number of legal proceedings resulting from our business, such as employment matters, product liability claims and general liability claims related to our store premises. We calculate contingent loss accruals using our best estimate of our probable and reasonably estimable contingent liabilities, such as lawsuits and our retained liability for insured claims.

We retain a significant portion of the risk for our workers' compensation, employee health insurance, general liability, property loss and vehicle coverage. These costs are significant primarily due to the large employee base and number of stores. Provisions are made for these insurance liabilities based on actual claim data and estimates of incurred but not reported claims developed by an independent actuary and internally developed lag analyses utilizing historical claim trends. The actuarial estimated long-term portions of these liabilities are recorded at our estimate of their net present value. If future claim trends deviate from historical patterns, we may be required to record additional expenses or expense reductions, which could be material to our future financial results.

*Vendor Allowances*

AutoZone receives various payments and allowances from its vendors based on the volume of purchases or for services that AutoZone provides to the vendors. Monies received from vendors include rebates, allowances and promotional funds. The amounts to be received are subject to purchase volumes and the terms of the vendor agreements, which generally do not state an expiration date, but are subject to ongoing negotiations that may be impacted in the future based on changes in market conditions, vendor marketing strategies and changes in the profitability or sell-through of the related merchandise.

Rebates and other miscellaneous incentives are earned based on purchases or product sales and are accrued ratably over the purchase of the related product, but only if it is reasonably certain that the required volume levels will be reached. These monies are recorded as a reduction of inventories and are recognized as a reduction to cost of sales as the inventories are sold.

Certain vendor allowances are used exclusively for promotions and to partially or fully offset certain other direct expenses. Such vendor funding arrangements that were entered into on or before December 31, 2002, were recognized as a reduction to operating, selling, general and administrative expenses when earned. However, for such vendor funding arrangements entered into or modified after December 31, 2002, AutoZone applied the new guidance pursuant to the Emerging Issues Task Force Issue No. 02-16, "Accounting by a Customer (including a Reseller) for Cash Consideration Received from a Vendor" ("EITF 02-16"). Accordingly, all vendor funds from arrangements entered into or modified after December 31, 2002, were recognized as a reduction to cost of sales as the inventories were sold.

This accounting pronouncement for vendor funding has not impacted the way AutoZone runs its business or its relationships with vendors. It does, however, require the deferral of certain vendor funding which is calculated based upon vendor inventory turns.

*Impairments*

In accordance with the provisions of Statement of Financial Accounting Standards No. 144, "Accounting for the Impairment or Disposal of Long-Lived Assets" ("SFAS 144"), we evaluate the recoverability of the carrying amounts of long-lived assets, such as property and equipment, covered by this standard whenever events or changes in circumstances dictate that the carrying value may not be recoverable. As part of the evaluation, we review performance at the store level to identify any stores with current period operating losses that should be considered for impairment. We compare the sum of the undiscounted expected future cash flows with the carrying amounts of the assets.

Under the provisions of Statement of Financial Accounting Standards No. 142, "Goodwill and Other Intangible Assets" ("SFAS 142"), we perform an annual test of goodwill to compare the estimated fair value of goodwill to the carrying amount to determine if any impairment exists. We perform the annual impairment assessment in the fourth quarter of each fiscal year, unless circumstances dictate more frequent assessments.

If impairments are indicated by either of the above evaluations, the amount by which the carrying amount of the assets exceeds the fair value of the assets is recognized as an impairment loss. Such evaluations require management to make certain assumptions based upon information available at the time the evaluation is performed, which could differ from actual results.

*Product Warranties*

Limited warranties on certain products that range from 30 days to lifetime are provided to our customers by AutoZone or the vendors supplying our products. Warranty costs relating to merchandise sold under warranty not covered by vendors are estimated and recorded as warranty obligations at the time of sale based on each product's historical return rate. During fiscal 2004 and 2003, we successfully negotiated with certain vendors to transfer warranty obligations to such vendors in order to minimize our warranty exposure resulting in credits to earnings. As a result, our remaining warranty liability was reduced to an immaterial amount during fiscal 2004 and has continued to decline since. Prior to these negotiations, the obligations, which were often funded by vendor allowances, were recorded as a component of accrued expenses in our consolidated balance sheets.

**Quantitative and Qualitative Disclosures About Market Risk**

AutoZone is exposed to market risk from, among other things, changes in interest rates, foreign exchange rates and fuel prices. From time to time, we use various financial instruments to reduce interest rate and fuel price risks. To date, based upon our current level of foreign operations, hedging costs and past changes in the associated foreign exchange rates, no instruments have been utilized to reduce foreign exchange rate risk. All of our hedging activities are governed by guidelines that are authorized by our Board of Directors. Further, we do not buy or sell financial instruments for trading purposes.

*Interest Rate Risk*

AutoZone's financial market risk results primarily from changes in interest rates. At times, we reduce our exposure to changes in interest rates by entering into various interest rate hedge instruments such as interest rate swap contracts, treasury lock agreements and forward-starting interest rate swaps.

(continued)

AutoZone has utilized interest rate swaps to convert variable rate debt to fixed rate debt and to lock in fixed rates on future debt issuances. We reflect the current fair value of all interest rate hedge instruments on our consolidated balance sheets as a component of other assets. At August 27, 2005, we had an outstanding interest rate swap with a fair value of \$4.3 million to effectively fix the interest rate on the \$300.0 million term loan entered into during December 2004. At August 28, 2004, the Company had an outstanding five-year forward-starting interest rate swap with a notional amount of \$300 million. This swap had a fair value of \$4.6 million at August 28, 2004 and was settled during November 2004 with no debt being issued.

The related gains and losses on interest rate hedges are deferred in stockholders' equity as a component of other comprehensive income or loss. These deferred gains and losses are recognized in income as a decrease or increase to interest expense in the period in which the related interest rates being hedged are recognized in expense. However, to the extent that the change in value of an interest rate hedge instrument does not perfectly offset the change in the value of the interest rate being hedged, that ineffective portion is immediately recognized in income. The Company's hedge instruments have been determined to be highly effective as of August 27, 2005.

The fair value of our debt was estimated at \$1.868 billion as of August 27, 2005, and \$1.880 billion as of August 28, 2004, based on the quoted market prices for the same or similar debt issues or on the current rates available to AutoZone for debt of the same remaining maturities. Such fair value is greater than the carrying value of debt by \$6.3 million at August 27, 2005, and by \$11.1 million at August 28, 2004. Considering the effect of any interest rate swaps designated and effective as cash flow hedges, we had \$221.9 million of variable rate debt outstanding at August 27, 2005, and \$529.3 million outstanding at August 28, 2004. At these borrowing levels for variable rate debt, a one percentage point increase in interest rates would have had an unfavorable impact on our pre-tax earnings and cash flows of \$2.2 million in 2005 and \$5.3 million in fiscal 2004, which includes the effects of interest rate swaps. The primary interest rate exposure on variable rate debt is based on LIBOR. Considering the effect of any interest rate swaps designated and effective as cash flow hedges, we had outstanding fixed rate debt of \$1.640 billion at August 27, 2005, and \$1.340 billion at August 28, 2004. A one percentage point increase in interest rates would reduce the fair value of our fixed rate debt by \$65.6 million at August 27, 2005, and \$81.1 million at August 28, 2004.

#### Fuel Price Risk

Fuel swap contracts utilized by us have not previously been designated as hedging instruments under the provisions of SFAS 133 and thus do not qualify for hedge accounting treatment, although the instruments were executed to economically hedge the consumption of diesel fuel used to distribute our products. Accordingly, mark-to-market gains and losses related to such fuel swap contracts are recorded in cost of sales as a component of distribution costs. As of August 27, 2005, the current month's fuel swap contract was outstanding with a settlement date of August 31, 2005. During fiscal 2005 and 2004, we entered into fuel swaps to economically hedge a portion of our diesel fuel exposure. These swaps were settled within a few days of each fiscal year end and had no significant impact on cost of sales for the 2005 or 2004 fiscal years.

#### Reconciliation of Non-GAAP Financial Measures

"Selected Financial Data" and "Management's Discussion and Analysis of Financial Condition and Results of Operations" include certain financial measures not derived in accordance with generally accepted accounting principles ("GAAP"). These non-GAAP financial measures provide additional information for determining our optimum capital structure and are used to assist management in evaluating performance and in making appropriate business decisions to maximize stockholders' value.

Non-GAAP financial measures should not be used as a substitute for GAAP financial measures, or considered in isolation, for the purpose of analyzing our operating performance, financial position or cash flows. However, we have presented the non-GAAP financial measures, as we believe they provide additional information to analyze or compare our operations. Furthermore, our management and Compensation Committee of the Board of Directors use the abovementioned non-GAAP financial measures to analyze and compare our underlying operating results and to determine payments of performance-based compensation. We have included a reconciliation of this information to the most comparable GAAP measures in the following reconciliation tables.

#### Reconciliation of Non-GAAP Financial Measure: Cash Flow Before Share Repurchases and Changes in Debt

The following table reconciles net increase (decrease) in cash and cash equivalents to cash flow before share repurchases and changes in debt, which is presented in the "Selected Financial Data."

(in thousands)	Fiscal Year Ended August				
	2005	2004	2003	2002	2001
Net increase (decrease) in cash and cash equivalents	\$ (2,042)	\$ (16,250)	\$ 22,796	\$ (3,709)	\$ 8,680
Less: Increase (decrease) in debt	(7,400)	322,405	352,328	(30,885)	(24,535)
Less: Share repurchases	(426,852)	(848,102)	(891,095)	(698,983)	(366,097)
Cash flow before share repurchases and changes in debt	\$ 432,210	\$ 509,447	\$ 561,563	\$ 726,159	\$ 399,312

*Reconciliation of Non-GAAP Financial Measure: After-Tax Return on Invested Capital*

The following table reconciles the percentages of after-tax return on invested capital, or "ROIC," both including and excluding the fiscal 2001 restructuring and impairment charges, to net income. After-tax return on invested capital is calculated as after-tax operating profit (excluding rent) divided by average invested capital (which includes a factor to capitalize operating leases). The ROIC percentages are presented in the "Selected Financial Data."

(in thousands, except per share and percentage data)	Fiscal Year Ended August				
	2005	2004	2003	2002	2001
Net income	\$ 571,019	\$ 566,202	\$ 517,604	\$ 428,148	\$ 175,526
Adjustments:					
After-tax interest	65,533	58,003	52,686	49,471	61,560
After-tax rent	96,367	73,086	68,764	61,348	61,396
After-tax return	732,919	697,291	639,054	538,967	298,482
After-tax restructuring and impairment charges	—	—	—	—	95,822
After-tax return, excluding restructuring and impairment charges	\$ 732,919	\$ 697,291	\$ 639,054	\$ 538,967	\$ 394,304
Average debt <sup>(1)</sup>	\$1,969,639	\$1,787,307	\$1,484,987	\$1,329,077	\$1,445,899
Average equity <sup>(2)</sup>	316,639	292,802	580,176	802,289	879,912
Rent x 6 <sup>(3)</sup>	774,706	701,621	663,990	594,192	602,382
Pre-tax invested capital	3,060,984	2,781,730	2,729,153	2,725,558	2,928,193
Average equity, excluding restructuring and impairment charges <sup>(4)</sup>	—	—	—	—	6,844
Pre-tax invested capital, excluding restructuring and impairment charges	\$3,060,984	\$2,781,730	\$2,729,153	\$2,725,558	\$2,935,037
ROIC	23.9%	25.1%	23.4%	19.8%	10.1%
ROIC, before restructuring and impairment charges	23.9%	25.1%	23.4%	19.8%	13.4%

(1) Average debt is equal to the average of our long-term debt measured at the end of the prior fiscal year and each of the 13 fiscal periods in the current fiscal year. Long-term debt (in thousands) was \$1,249,937 at August 26, 2000.

(2) Average equity is equal to the average of our stockholders' equity measured at the end of the prior fiscal year and each of the 13 fiscal periods of the current fiscal year. Stockholders' equity (in thousands) was \$992,179 at August 26, 2000.

(3) Rent is multiplied by a factor of six to capitalize operating leases in the determination of pre-tax invested capital. This calculation excludes the impact from the cumulative lease accounting adjustments recorded in the second quarter of fiscal 2005.

(4) Average equity at August 25, 2001, increased by \$6.8 million as a result of excluding restructuring and impairment charges.

## Management's Report on Internal Control Over Financial Reporting

Our management is responsible for establishing and maintaining adequate internal control over financial reporting (as defined in Rules 13a-15(f) and 15d-15(f) under the Securities Exchange Act of 1934, as amended). Our internal control over financial reporting includes, among other things, defined policies and procedures for conducting and governing our business, sophisticated information systems for processing transactions and properly trained staff. Mechanisms are in place to monitor the effectiveness of our internal control over financial reporting, including regular testing performed by Deloitte & Touche LLP, the Company's internal auditors. Actions are taken to correct deficiencies as they are identified. Our procedures for financial reporting include the active involvement of senior management, our Audit Committee and a staff of highly qualified financial and legal professionals.

Management, with the participation of our principal executive and financial officers, assessed our internal control over financial reporting as of August 27, 2005, the end of our fiscal year. Management based its assessment on criteria established in Internal Control—Integrated Framework issued by the Committee of Sponsoring Organizations of the Treadway Commission (the COSO criteria).

Based on this assessment, management has concluded that our internal control over financial reporting was effective as of August 27, 2005.

Our independent registered public accounting firm, Ernst & Young LLP, audited management's assessment and the effectiveness of our internal control over financial reporting. Ernst & Young has issued their report concurring with management's assessment, which is included in this Annual Report.

### **Certifications**

#### *Compliance with NYSE Corporate Governance Listing Standards*

On November 29, 2004, the Company submitted to the New York Stock Exchange the Annual CEO Certification required pursuant to Section 303A.12(a) of the New York Stock Exchange Listed Company Manual for the fiscal year ended August 28, 2004.

#### *Rule 13a-14(a) Certifications of Chief Executive Officer and Principal Accounting Officer*

The Company has filed, as exhibits to its Annual Report on Form 10-K for the fiscal year ended August 27, 2005, the certifications of its Chief Executive Officer and Principal Accounting Officer required pursuant to Section 302 of the Sarbanes-Oxley Act of 2004.

*Report of Independent Registered Public Accounting Firm  
on Internal Controls Over Financial Reporting*

---

To the Board of Directors and Stockholders of  
AutoZone, Inc.

We have audited management's assessment, included in the accompanying Management's Report on Internal Control Over Financial Reporting, that AutoZone, Inc. maintained effective internal control over financial reporting as of August 27, 2005, based on criteria established in Internal Control—Integrated Framework issued by the Committee of Sponsoring Organizations of the Treadway Commission (the COSO criteria). AutoZone, Inc.'s management is responsible for maintaining effective internal control over financial reporting and for its assessment of the effectiveness of internal control over financial reporting. Our responsibility is to express an opinion on management's assessment and an opinion on the effectiveness of the Company's internal control over financial reporting based on our audit.

We conducted our audit in accordance with the standards of the Public Company Accounting Oversight Board (United States). Those standards require that we plan and perform the audit to obtain reasonable assurance about whether effective internal control over financial reporting was maintained in all material respects. Our audit included obtaining an understanding of internal control over financial reporting, evaluating management's assessment, testing and evaluating the design and operating effectiveness of internal control, and performing such other procedures as we considered necessary in the circumstances. We believe that our audit provides a reasonable basis for our opinion.

A company's internal control over financial reporting is a process designed to provide reasonable assurance regarding the reliability of financial reporting and the preparation of financial statements for external purposes in accordance with generally accepted accounting principles. A company's internal control over financial reporting includes those policies and procedures that (1) pertain to the maintenance of records that, in reasonable detail, accurately and fairly reflect the transactions and dispositions of the assets of the company; (2) provide reasonable assurance that transactions are recorded as necessary to permit preparation of financial statements in accordance with generally accepted accounting principles, and that receipts and expenditures of the company are being made only in accordance with authorizations of management and directors of the company; and (3) provide reasonable assurance regarding prevention or timely detection of unauthorized acquisition, use, or disposition of the company's assets that could have a material effect on the financial statements.

Because of its inherent limitations, internal control over financial reporting may not prevent or detect misstatements. Also, projections of any evaluation of effectiveness to future periods are subject to the risk that controls may become inadequate because of changes in conditions, or that the degree of compliance with the policies or procedures may deteriorate.

In our opinion, management's assessment that AutoZone, Inc. maintained effective internal control over financial reporting as of August 27, 2005, is fairly stated, in all material respects, based on the COSO criteria. Also, in our opinion, AutoZone, Inc. maintained, in all material respects, effective internal control over financial reporting as of August 27, 2005, based on the COSO criteria.

We also have audited, in accordance with the standards of the Public Company Accounting Oversight Board (United States), the consolidated balance sheets of AutoZone, Inc. as of August 27, 2005 and August 28, 2004 and the related consolidated statements of income, stockholders' equity, and cash flows for each of the three years in the period ended August 27, 2005 of AutoZone, Inc. and our report dated October 19, 2005 expressed an unqualified opinion thereon.

Memphis, Tennessee  
October 19, 2005

*Ernst & Young LLP*

*Report of Independent Registered Public Accounting Firm*

To the Board of Directors and Stockholders of  
AutoZone, Inc.

We have audited the accompanying consolidated balance sheets of AutoZone, Inc. as of August 27, 2005 and August 28, 2004, and the related consolidated statements of income, stockholders' equity and cash flows for each of the three years in the period ended August 27, 2005. These financial statements are the responsibility of the Company's management. Our responsibility is to express an opinion on these financial statements based on our audits.

We conducted our audits in accordance with the standards of the Public Company Accounting Oversight Board (United States). Those standards require that we plan and perform the audit to obtain reasonable assurance about whether the financial statements are free of material misstatement. An audit includes examining, on a test basis, evidence supporting the amounts and disclosures in the financial statements. An audit also includes assessing the accounting principles used and significant estimates made by management, as well as evaluating the overall financial statement presentation. We believe that our audits provide a reasonable basis for our opinion.

In our opinion, the consolidated financial statements referred to above present fairly, in all material respects, the consolidated financial position of AutoZone, Inc. as of August 27, 2005 and August 28, 2004, and the consolidated results of its operations and its cash flows for each of the three years in the period ended August 27, 2005, in conformity with U.S. generally accepted accounting principles.

As discussed in Note A, "Vendor Allowances and Advertising Costs," to the consolidated financial statements, in fiscal 2003, the Company adopted Emerging Issues Task Force Issue No. 02-16, "Accounting by a Customer (Including a Reseller) for Certain Consideration Received from a Vendor."

We also have audited, in accordance with the standards of the Public Company Accounting Oversight Board (United States), the effectiveness of AutoZone, Inc.'s internal control over financial reporting as of August 27, 2005, based on criteria established in Internal Control—Integrated Framework issued by the Committee of Sponsoring Organizations of the Treadway Commission and our report dated October 19, 2005 expressed an unqualified opinion thereon.

Memphis, Tennessee  
October 19, 2005

*Ernst & Young LLP*



## Consolidated Statements of Income

	Year Ended		
	August 27, 2005 (52 Weeks)	August 28, 2004 (52 Weeks)	August 30, 2003 (52 Weeks)
(in thousands, except per share data)			
Net sales	\$5,710,882	\$5,637,025	\$5,457,123
Cost of sales, including warehouse and delivery expenses	2,918,334	2,880,446	2,942,114
Operating, selling, general and administrative expenses	1,816,884	1,757,873	1,597,212
Operating profit	975,664	998,706	917,797
Interest expense, net	102,443	92,804	84,790
Income before income taxes	873,221	905,902	833,007
Income taxes	302,202	339,700	315,403
Net income	\$ 571,019	\$ 566,202	\$ 517,604
Weighted average shares for basic earnings per share	78,530	84,993	94,906
Effect of dilutive stock equivalents	978	1,357	2,057
Adjusted weighted average shares for diluted earnings per share	79,508	86,350	96,963
Basic earnings per share	\$ 7.27	\$ 6.66	\$ 5.45
Diluted earnings per share	\$ 7.18	\$ 6.56	\$ 5.34

See Notes to Consolidated Financial Statements.

## Consolidated Balance Sheets

(in thousands, except per share data)	August 27, 2005	August 28, 2004
<b>Assets</b>		
Current assets:		
Cash and cash equivalents	\$ 74,810	\$ 76,852
Accounts receivable	118,263	68,372
Merchandise inventories	1,663,860	1,561,479
Other current assets	72,526	49,054
Total current assets	1,929,459	1,755,757
Property and equipment:		
Land	559,231	538,920
Buildings and improvements	1,450,814	1,370,079
Equipment	662,495	574,882
Leasehold improvements	150,846	137,562
Construction in progress	155,251	87,694
	2,978,637	2,709,137
Less: Accumulated depreciation and amortization	1,041,022	919,048
	1,937,615	1,790,089
Goodwill, net of accumulated amortization	302,699	301,015
Deferred income taxes	32,917	—
Other long-term assets	42,567	65,704
	378,183	366,719
	<b>\$4,245,257</b>	<b>\$3,912,565</b>
<b>Liabilities and Stockholders' Equity</b>		
Current liabilities:		
Accounts payable	\$1,539,776	\$1,429,128
Accrued expenses	255,672	243,816
Income taxes payable	4,753	72,096
Deferred income taxes	10,958	6,011
Total current liabilities	1,811,159	1,751,051
Long-term debt	1,861,850	1,869,250
Other liabilities	181,241	115,143
Deferred income taxes	—	5,728
Commitments and contingencies	—	—
Stockholders' equity:		
Preferred stock, authorized 1,000 shares; no shares issued	—	—
Common stock, par value \$.01 per share, authorized 200,000 shares; 81,111 shares issued and 76,539 shares outstanding in 2005 and 89,393 shares issued and 79,628 shares outstanding in 2004	811	894
Additional paid-in capital	462,289	414,231
Retained earnings	370,276	580,147
Accumulated other comprehensive loss	(36,581)	(15,653)
Treasury stock, at cost	(405,788)	(808,226)
Total stockholders' equity	391,007	171,393
	<b>\$4,245,257</b>	<b>\$3,912,565</b>

See Notes to Consolidated Financial Statements.

## Consolidated Statements of Cash Flows

	Year Ended		
	August 27, 2005 (52 Weeks)	August 28, 2004 (52 Weeks)	August 30, 2003 (52 Weeks)
(in thousands)			
Cash flows from operating activities:			
Net income	\$ 571,019	\$ 566,202	\$ 517,604
Adjustments to reconcile net income to net cash provided by operating activities:			
Depreciation and amortization of property and equipment	135,597	106,891	109,748
Deferred rent liability adjustment	21,527	—	—
Amortization of debt origination fees	2,343	4,230	7,334
Income tax benefit realized from exercise of options	31,828	24,339	37,402
Gains from warranty negotiations	(1,736)	(42,094)	(8,695)
Changes in operating assets and liabilities:			
Deferred income taxes	(16,628)	44,498	65,701
Accounts receivable	(42,485)	3,759	(19,964)
Merchandise inventories	(124,566)	(119,539)	(135,732)
Accounts payable and accrued expenses	109,341	43,612	164,201
Income taxes payable	(67,343)	32,118	(3,460)
Other, net	29,186	(25,637)	(13,332)
Net cash provided by operating activities	648,083	638,379	720,807
Cash flows from investing activities:			
Capital expenditures	(283,478)	(184,870)	(182,242)
Acquisitions	(3,090)	(11,441)	—
Proceeds from disposal of capital assets	3,797	2,590	14,443
Net cash used in investing activities	(282,771)	(193,721)	(167,799)
Cash flows from financing activities:			
Net change in commercial paper	(304,700)	254,400	44,800
Proceeds from issuance of debt	300,000	500,000	500,000
Repayment of debt	—	(431,995)	(215,000)
Net proceeds from sale of common stock	64,547	33,552	45,303
Purchase of treasury stock	(426,852)	(848,102)	(891,095)
Settlement of interest rate hedge instruments	—	32,166	(28,524)
Other	(349)	(929)	14,304
Net cash used in financing activities	(367,354)	(460,908)	(530,212)
Net increase (decrease) in cash and cash equivalents	(2,042)	(16,250)	22,796
Cash and cash equivalents at beginning of year	76,852	93,102	70,306
Cash and cash equivalents at end of year	\$ 74,810	\$ 76,852	\$ 93,102
Supplemental cash flow information:			
Interest paid, net of interest cost capitalized	\$ 98,937	\$ 77,871	\$ 77,533
Income taxes paid	\$ 339,245	\$ 237,010	\$ 215,760

See Notes to Consolidated Financial Statements.

## Consolidated Statements of Stockholders' Equity

(in thousands)	Common Shares Issued	Common Stock	Additional Paid-in Capital	Retained Earnings	Accumulated Other Comprehensive Loss	Treasury Stock	Total
Balance at August 31, 2002	109,962	\$1,100	\$370,457	\$ 974,141	\$(11,603)	\$(644,968)	\$ 689,127
Net income				517,604			517,604
Minimum pension liability net of taxes of \$(18,072)					(29,739)		(29,739)
Foreign currency translation adjustment					(8,276)		(8,276)
Net gains on outstanding derivatives net of taxes of \$15,710					25,856		25,856
Net losses on terminated/matured derivatives					(20,014)		(20,014)
Reclassification of net losses on derivatives into earnings					6,479		6,479
Comprehensive income							491,910
Purchase of 12,266 shares of treasury stock			1,111			(891,095)	(889,984)
Retirement of treasury stock	(11,000)	(110)	(43,120)	(622,006)		665,236	—
Sale of common stock under stock option and stock purchase plans	1,708	17	45,112			174	45,303
Tax benefit of exercise of stock options			37,402				37,402
Balance at August 30, 2003	100,670	1,007	410,962	869,739	(37,297)	(870,653)	373,758
Net income				566,202			566,202
Minimum pension liability net of taxes of \$10,750					17,537		17,537
Foreign currency translation adjustment					(3,841)		(3,841)
Net gains on outstanding derivatives net of taxes of \$1,740					2,900		2,900
Net gains on terminated/matured derivatives net of taxes of (\$15,710)					6,226		6,226
Reclassification of derivative ineffectiveness into earnings					(2,701)		(2,701)
Reclassification of net losses on derivatives into earnings					1,523		1,523
Comprehensive income							587,846
Purchase of 10,194 shares of treasury stock						(848,102)	(848,102)
Retirement of treasury stock	(12,400)	(124)	(54,611)	(855,794)		910,529	—
Sale of common stock under stock option and stock purchase plans	1,123	11	33,541				33,552
Tax benefit of exercise of stock options			24,339				24,339
Balance at August 28, 2004	89,393	894	414,231	580,147	(15,653)	(808,226)	171,393
Net income				571,019			571,019
Minimum pension liability net of taxes of (\$16,925)					(25,293)		(25,293)
Foreign currency translation adjustment					5,160		5,160
Net gains on outstanding derivatives net of taxes of \$1,589					2,717		2,717
Reclassification of derivative ineffectiveness into earnings net of taxes of (\$1,740)					(2,900)		(2,900)
Reclassification of net gains on derivatives into earnings					(612)		(612)
Comprehensive income							550,091
Purchase of 4,822 shares of treasury stock						(426,852)	(426,852)
Retirement of treasury stock	(10,000)	(100)	(48,300)	(780,890)		829,290	—
Sale of common stock under stock option and stock purchase plans	1,718	17	64,530				64,547
Tax benefit of exercise of stock options			31,828				31,828
<b>Balance at August 27, 2005</b>	<b>81,111</b>	<b>\$ 811</b>	<b>\$462,289</b>	<b>\$ 370,276</b>	<b>\$(36,581)</b>	<b>\$(405,788)</b>	<b>\$ 391,007</b>

See Notes to Consolidated Financial Statements.

## Notes to Consolidated Financial Statements

### Note A—Significant Accounting Policies

#### *Business*

AutoZone, Inc. and its wholly owned subsidiaries ("AutoZone" or the "Company") is principally a retailer of automotive parts and accessories. At the end of fiscal 2005, the Company operated 3,592 domestic stores in 48 states, the District of Columbia, and Puerto Rico and 81 stores in Mexico. Each store carries an extensive product line for cars, sport utility vehicles, vans and light trucks, including new and remanufactured automotive hard parts, maintenance items, accessories and non-automotive products. Many of the stores have a commercial sales program that provides commercial credit and prompt delivery of parts and other products to local, regional and national repair garages, dealers and service stations. The Company also sells the ALLDATA brand automotive diagnostic and repair software. On the web, the Company sells automotive diagnostic and repair information and auto and light truck parts through [www.autozone.com](http://www.autozone.com).

#### *Fiscal Year*

The Company's fiscal year consists of 52 or 53 weeks ending on the last Saturday in August.

#### *Basis of Presentation*

The consolidated financial statements include the accounts of AutoZone, Inc. and its wholly owned subsidiaries. All significant intercompany transactions and balances have been eliminated in consolidation.

#### *Use of Estimates*

Management of the Company has made a number of estimates and assumptions relating to the reporting of assets and liabilities and the disclosure of contingent liabilities to prepare these financial statements. Actual results could differ from those estimates.

#### *Reclassifications*

To conform to current year presentation, certain prior year amounts have been reclassified within the consolidated statements of cash flows and the consolidated balance sheet. Prior year presentations had included certain long-term obligations within accrued expense; these amounts have now been reclassified to other non-current liabilities for all periods presented.

#### *Cash Equivalents*

Cash equivalents consist of investments with original maturities of 90 days or less at the date of purchase. Excluded from cash equivalents are investments in money market accounts, held by the Company's wholly owned insurance captive that was established during fiscal 2004. These investments approximated \$40.2 million at August 27, 2005, and \$20.1 million at August 28, 2004, and are included within the other current assets caption and are recorded at cost, which approximates market value, due to the short maturity of the investments.

#### *Accounts Receivable*

Accounts receivable consists of receivables from customers and vendors, including the current portion of long-term receivables from certain vendors, and are presented net of an allowance for uncollectible accounts. AutoZone routinely grants credit to certain of its commercial customers. The risk of credit loss in our trade receivables is substantially mitigated by our credit evaluation process, short collection terms and sales to a large number of customers, as well as the low revenue per transaction for most of our sales. Allowances for potential credit losses are determined based on historical experience and current evaluation of the composition of accounts receivable. Historically, credit losses have been within management's expectations and the allowance for uncollectible accounts were insignificant at August 27, 2005, and August 28, 2004.

#### *Merchandise Inventories*

Inventories are stated at the lower of cost or market using the last-in, first-out (LIFO) method. Included in inventory are related purchasing, storage and handling costs. Due to price deflation on the Company's merchandise purchases, the Company's inventory balances are effectively maintained under the first-in, first-out method as the Company's policy is not to write up inventory for favorable LIFO adjustments, resulting in cost of sales being reflected at the higher amount. The cumulative balance of this unrecorded adjustment, which will be reduced upon experiencing price inflation on our merchandise purchases, was \$166.8 million at August 27, 2005, and \$157.5 million at August 28, 2004.

AutoZone has entered into pay-on-scan ("POS") arrangements with certain vendors, whereby AutoZone will not purchase merchandise supplied by a vendor until that merchandise is ultimately sold to AutoZone's customers. Title and certain risks of ownership remain with the vendor until the merchandise is sold to AutoZone's customers. Since the Company does not own merchandise under POS arrangements until just before it is sold to a customer, such merchandise is not recorded on the Company's balance sheet. Upon the sale of the merchandise to AutoZone's customers, AutoZone recognizes the liability for the goods and pays the vendor in accordance with the agreed-upon terms. Although AutoZone does not hold title to the goods, AutoZone controls pricing and has credit collection risk and therefore, revenues under POS arrangements are included gross in net sales in the income statement. Sales of merchandise under POS arrangement approximated \$460.0 million in fiscal 2005 and \$160.0 million in fiscal 2004. There were no sales of POS merchandise in fiscal 2003. AutoZone has financed the repurchase of existing merchandise inventory by certain vendors in order to convert such vendors to POS arrangements. These receivables have durations up to 25 months and approximated \$49.9 million at August 27, 2005, and \$58.3 million at August 28, 2004. The current portion of these receivables is reflected in accounts receivable and approximated \$37.5 million at August 27, 2005 and \$27.8 million at August 28, 2004. The long-term portion is reflected as a component of other long-term assets and approximated \$12.4 million at August 27, 2005 and \$30.5 million at August 28, 2004. Merchandise under POS arrangements was \$151.7 million at August 27, 2005, and \$146.6 million at August 28, 2004.

#### *Property and Equipment*

Property and equipment is stated at cost. Depreciation is computed principally using the straight-line method over the following estimated useful lives: buildings, 40 to 50 years; building improvements, 5 to 15 years; equipment, 3 to 7 years; and leasehold improvements over the shorter of the asset's estimated useful life or the remaining lease term, which includes any reasonably assured renewal periods.

#### *Impairment of Long-Lived Assets*

In accordance with the provisions of Statement of Financial Accounting Standards No. 144, "Accounting for the Impairment or Disposal of Long-Lived Assets" ("SFAS 144"), the Company evaluates the recoverability of the carrying amounts of the assets covered by this standard annually and more frequently if events or changes in circumstances indicate that the carrying value may not be recoverable. As part of the evaluation, the Company reviews performance at the store level to identify any stores with current period operating losses that should be considered for impairment. The Company compares the sum of the undiscounted expected future cash flows with the carrying amounts of the assets. If impairments are indicated, the amount by which the carrying amount of the assets exceeds the fair value of the assets is recognized as an impairment loss. No significant impairment losses were recorded in the three years ended August 27, 2005.

#### *Goodwill*

The cost in excess of fair value of identifiable net assets of businesses acquired is recorded as goodwill. In accordance with the provisions of Statement of Financial Accounting Standards No. 142, "Goodwill and Other Intangible Assets" ("SFAS 142"), goodwill has not been amortized since fiscal 2001, but an analysis is performed at least annually to compare the fair value of goodwill to the carrying amount to determine if any impairment exists. The Company performs its annual impairment assessment in the fourth quarter of each fiscal year, unless circumstances dictate more frequent assessments. No impairment losses were recorded in the three years ended August 27, 2005.

#### *Derivative Instruments and Hedging Activities*

AutoZone is exposed to market risk from, among other things, changes in interest rates, foreign exchange rates and fuel prices. From time to time, the Company uses various financial instruments to reduce such risks. To date, based upon the Company's current level of foreign operations, hedging costs and past changes in the associated foreign exchange rates, no instruments have been utilized to reduce this market risk. All of the Company's hedging activities are governed by guidelines that are authorized by AutoZone's Board of Directors. Further, the Company does not buy or sell financial instruments for trading purposes.

AutoZone's financial market risk results primarily from changes in interest rates. At times, AutoZone reduces its exposure to changes in interest rates by entering into various interest rate hedge instruments such as interest rate swap contracts, treasury lock agreements and forward-starting interest rate swaps. The Company complies with Statement of Financial Accounting Standards Nos. 133, 137, 138 and 149 (collectively "SFAS 133") pertaining to the accounting for these derivatives and hedging activities which require all such interest rate hedge instruments to be recognized on the balance sheet at fair value. All of the Company's interest rate hedge instruments are designated as cash flow hedges. Refer to "Note B—Derivative Instruments and Hedging Activities" for additional disclosures regarding the Company's derivatives instruments and hedging activities.

#### *Self-Insurance Reserves*

The Company retains a significant portion of the risks associated with workers' compensation, health, general and auto liability claims. Through various methods, which include analyses of historical trends and utilization of actuaries, the Company estimates the costs of these risks. The actuarial estimated long-term portions of these liabilities are recorded at our estimate of their net present value.

#### *Deferred Rent*

The Company recognizes rent expense on a straight-line basis over the course of the lease term and any reasonably assured renewal periods, which begin on the date the Company takes physical possession of the property (see "Note J—Leases"). Differences between this calculated expense and cash payments are recorded as a liability in accrued expenses and other liabilities on the accompanying balance sheet. This deferred rent approximated \$27.9 million on August 27, 2005 and \$1.0 million on August 28, 2004.

#### *Financial Instruments*

The Company has financial instruments, including cash, accounts receivable, other current assets and accounts payable. The carrying amounts of these financial instruments approximate fair value because of their short maturities. A discussion of the carrying values and fair values of the Company's debt is included in "Note E—Financing," while a discussion of the fair values of the Company's derivatives is included in "Note B—Derivative Instruments and Hedging Activities."

#### *Income Taxes*

The Company accounts for income taxes under the liability method. Deferred tax assets and liabilities are determined based on differences between financial reporting and tax bases of assets and liabilities and are measured using the enacted tax rates and laws that will be in effect when the differences are expected to reverse.

### *Revenue Recognition*

The Company recognizes sales at the time the sale is made and the product is delivered to the customer. Revenue from sales are presented net of allowances for estimated sales returns, which are based on historical return rates.

### *Vendor Allowances and Advertising Costs*

The Company receives various payments and allowances from its vendors based on the volume of purchases and for services that AutoZone provides to the vendors. Monies received from vendors include rebates, allowances and promotional funds. The amounts to be received are subject to purchase volumes and the terms of the vendor agreements, which generally do not state an expiration date, but are subject to ongoing negotiations that may be impacted in the future based on changes in market conditions, vendor marketing strategies and changes in the profitability or sell-through of the related merchandise. The Company's level of advertising and other operating, selling, general and administrative expenditures are not dependent on vendor allowances.

Rebates and other miscellaneous incentives are earned based on purchases or product sales and are accrued ratably over the purchase of the related product, but only if it is reasonably certain that the required volume levels will be reached. These monies are recorded as a reduction of inventories and are recognized as a reduction to cost of sales as the related inventories are sold.

For all allowances and promotional funds earned under vendor funding arrangements entered into or modified after December 31, 2002, the Company applied the guidance pursuant to the Emerging Issues Task Force Issue No. 02-16, "Accounting by a Customer (Including a Reseller) for Cash Consideration Received from a Vendor" ("EITF 02-16"), by recording the vendor funds as a reduction of inventories that are recognized as a reduction to cost of sales as the inventories are sold. The Company's vendor funding arrangements do not provide for any reimbursement arrangements that are for specific, incremental, identifiable costs that are permitted under EITF 02-16 for the funding to be recorded as a reduction to advertising or other operating, selling, general and administrative expenses.

Prior to applying EITF 02-16, certain vendor allowances and promotional funds earned under vendor funding arrangements entered into before December 31, 2002 were recognized as a reduction to advertising and other operating, selling, general and administrative expenses. Subsequent to fiscal 2003, vendor allowances did not reduce advertising or other operating, selling, general and administrative expenses, as all vendor funding arrangements entered into prior to December 31, 2002 had been modified or had expired. Vendor funding arrangements reduced advertising expense by \$44.0 million in fiscal 2003, resulting in net advertising expense of \$32.5 million. Advertising expense was approximately \$90.3 million in fiscal 2005 and \$98.1 million in fiscal 2004. The Company expenses advertising costs as incurred.

### *Warranty Costs*

The Company or the vendors supplying its products provide its customers with limited warranties on certain products. Estimated warranty obligations for which the Company is responsible are based on historical experience, provided at the time of sale of the product, and charged to cost of sales.

### *Shipping and Handling Costs*

The Company does not generally charge customers separately for shipping and handling. The cost the Company incurs to ship products to the stores for delivery to the customer is included in cost of sales.

### *Pre-opening Expenses*

Pre-opening expenses, which consist primarily of payroll and occupancy costs, are expensed as incurred.

### *Earnings Per Share*

Basic earnings per share is based on the weighted average outstanding common shares. Diluted earnings per share is based on the weighted average outstanding shares adjusted for the effect of common stock equivalents. At this time, stock options are the Company's only common stock equivalents. Stock options that were not included in the diluted computation because they would have been anti-dilutive were approximately 1.0 million shares at August 27, 2005.

### *Stock Options*

At August 27, 2005, the Company has stock option plans that provide for the purchase of the Company's common stock by some of its employees and directors, which are described more fully in "Note H—Employee Stock Plans." The Company accounts for those plans using the intrinsic-value-based recognition method prescribed by Accounting Principles Board ("APB") Opinion No. 25, "Accounting for Stock Issued to Employees," and related interpretations. Accordingly, no stock-based employee compensation cost is reflected in net income, as options are granted under those plans at an exercise price equal to the market value of the underlying common stock on the date of grant. Statement of Financial Accounting Standards No. 123, "Accounting for Stock-Based Compensation" ("SFAS 123"), and Statement of Financial Accounting Standards No. 148, "Accounting for

Stock-Based Compensation—Transition and Disclosure" ("SFAS 148"), established accounting and disclosure requirements using a fair-value-based method of accounting for stock-based employee compensation plans. As allowed under SFAS 123, the Company has elected to continue to apply the intrinsic-value-based method of accounting and has adopted only the disclosure requirements of SFAS 123 until the Company adopts Statement of Financial Accounting Standards No. 123 (revised 2004), "Share-Based Payment," (see "Recent Accounting Pronouncements"). The following table illustrates the effect on net income and earnings per share had the Company applied the fair-value recognition provisions of SFAS 123 to its share-based compensation arrangements:

(in thousands, except per share data)	Year Ended		
	August 27, 2005	August 28, 2004	August 30, 2003
Reported net income	\$571,019	\$566,202	\$517,604
Deduct total incremental stock-based compensation expense determined under fair-value-based method for all awards, net of related tax effects	11,255	16,518	14,506
Pro forma net income	\$559,764	\$549,684	\$503,098
Basic earnings per share:			
As reported	\$ 7.27	\$ 6.66	\$ 5.45
Pro forma	\$ 7.12	\$ 6.46	\$ 5.30
Diluted earnings per share:			
As reported	\$ 7.18	\$ 6.56	\$ 5.34
Pro forma	\$ 7.03	\$ 6.36	\$ 5.20

The weighted average fair value of the stock options granted was \$23.36 per share during fiscal 2005, \$28.07 per share during fiscal 2004, and \$24.59 per share during fiscal 2003. The fair value of each option granted is estimated on the date of the grant using the Black-Scholes option-pricing model with the following weighted average assumptions for grants in 2005, 2004, and 2003:

	Year Ended		
	August 27, 2005	August 28, 2004	August 30, 2003
Expected price volatility	36%	37%	38%
Risk-free interest rates	2.8%	2.4%	3.0%
Expected lives in years	3.5	3.8	4.2
Dividend yield	0%	0%	0%

#### Recent Accounting Pronouncements

During December 2004, the Financial Accounting Standards Board ("FASB") issued SFAS 123(R), "Share-Based Payment," which requires companies to measure and recognize compensation expense for all stock-based payments at fair value. Stock-based payments include stock option grants and certain transactions under other Company stock plans. AutoZone grants options to purchase common stock to some of its employees and directors under various plans at prices equal to the market value of the stock on the dates the options were granted. Non-employee directors receive at least a portion of their fees in common stock or deferred in units with values equivalent to the value of shares of common stock as of the grant date. Additionally, employees are allowed to purchase the Company's stock at a discount under various employee stock purchase plans. SFAS 123(R) is effective for all fiscal years beginning after June 15, 2005. The Company plans to apply the modified prospective method when adopting this pronouncement on August 28, 2005, which is the beginning of its next fiscal year.

As permitted by SFAS 123, the Company currently accounts for share-based payments to employees using APB 25's intrinsic value method and, as such, generally recognizes no compensation cost for employee stock options. Accordingly, the adoption of SFAS 123(R)'s fair value method will have an impact on our results of operations, but will not have an impact on our overall financial position. The impact of adoption of SFAS 123(R) cannot be predicted at this time because it will depend on, among other things, levels of share-based payments granted in the future and the market value of our common stock. However, had we adopted SFAS 123(R) in prior periods, the impact of that standard would have approximated the impact of SFAS 123 as described in the above disclosure of pro forma net income and earnings per share. SFAS 123(R) also requires the benefits of tax deductions in excess of recognized compensation cost to be reported as a financing cash flow, rather than as an operating cash flow as required under current literature. This requirement will reduce net operating cash flows and increase net financing cash flows in periods after adoption. While the Company cannot estimate what those amounts will be in the future (because they depend on, among other things, when employees exercise stock options), the amount of operating cash flows recognized in the accompanying consolidated statement of cash flows for such excess tax deductions were \$31.8 million in the current year, \$24.3 million in fiscal 2004, and \$37.4 million in fiscal 2003.



**Note B—Derivative Instruments and Hedging Activities**

AutoZone has utilized interest rate swaps to convert variable rate debt to fixed rate debt and to lock in fixed rates on future debt issuances. AutoZone reflects the current fair value of all interest rate hedge instruments on its consolidated balance sheets as a component of other assets. At August 27, 2005, the Company had an outstanding interest rate swap with a fair value of \$4.3 million to effectively fix the interest rate on the \$300.0 million term loan entered into during December 2004. At August 28, 2004, the Company had an outstanding five-year forward-starting interest rate swap with a notional amount of \$300 million. This swap had a fair value of \$4.6 million at August 28, 2004 and was settled during November 2004 with no debt being issued.

The related gains and losses on interest rate hedges are deferred in stockholders' equity as a component of other comprehensive income or loss. These deferred gains and losses are recognized in income as a decrease or increase to interest expense in the period in which the related interest rates being hedged are recognized in expense. However, to the extent that the change in value of an interest rate hedge instrument does not perfectly offset the change in the value of the interest rate being hedged, that ineffective portion is immediately recognized in income. The Company's hedge instruments have been determined to be highly effective as of August 27, 2005.

The following table summarizes the fiscal 2005 and 2004 activity in accumulated other comprehensive loss as it relates to interest rate hedge instruments:

(in thousands)	Before-Tax Amount	Income Tax	After-Tax Amount
Accumulated net gains as of August 30, 2003	\$17,586	\$(15,710)	\$ 1,876
Net gains on outstanding derivatives	4,640	(1,740)	2,900
Net gains on terminated/matured derivatives	(9,484)	15,710	6,226
Reclassification of derivative ineffectiveness into earnings	(2,701)	—	(2,701)
Reclassification of net losses on derivatives into earnings	1,523	—	1,523
Accumulated net gains as of August 28, 2004	11,564	(1,740)	9,824
Net gains on outstanding derivatives	4,306	(1,589)	2,717
Reclassification of derivative ineffectiveness into earnings	(4,640)	1,740	(2,900)
Reclassification of net gains on derivatives into earnings	(612)	—	(612)
<b>Accumulated net gains as of August 27, 2005</b>	<b>\$10,618</b>	<b>\$ (1,589)</b>	<b>\$ 9,029</b>

The Company primarily executes derivative transactions of relatively short duration with strong creditworthy counterparties. These counterparties expose the Company to credit risk in the event of non-performance. The amount of such exposure is limited to the unpaid portion of amounts due to the Company pursuant to the terms of the derivative financial instruments, if any. Although there are no collateral requirements, if a downgrade in the credit rating of these counterparties occurs, management believes that this exposure is mitigated by provisions in the derivative agreements which allow for the legal right of offset of any amounts due to the Company from the counterparties with amounts payable, if any, to the counterparties by the Company. Management considers the risk of counterparty default to be minimal.

**Note C—Accrued Expenses**

Accrued expenses at August 27, 2005, and August 28, 2004, consisted of the following:

(in thousands)	August 27, 2005	August 28, 2004
Medical and casualty insurance claims (current portion)	\$ 48,112	\$ 43,163
Accrued compensation; related payroll taxes and benefits	88,812	85,561
Property and sales taxes	49,340	46,780
Accrued interest	24,179	23,041
Accrued sales and warranty returns	7,179	11,493
Other	38,050	33,778
	<b>\$255,672</b>	<b>\$243,816</b>

The Company is self-insured for workers' compensation, vehicle, general and product liability and property losses. Beginning in fiscal 2004, a portion of these self-insured losses is managed through a wholly owned insurance captive. The Company is also self-insured for health care claims for eligible active employees. The Company maintains certain levels for stop-loss coverage for each self-insured plan in order to limit its liability for large claims. The limits are per claim and are \$500,000 for health, \$1.0 million for auto, general and products liability, and \$1.5 million for workers' compensation claims. Self-insurance costs are accrued based upon the aggregate of the liability for reported claims and an estimated liability for claims incurred but not reported. Estimates are based on calculations that consider historical lag and claim development factors.

## Notes to Consolidated Financial Statements

(continued)

The Company or the vendors supplying its products provide its customers limited warranties on certain products that range from 30 days to lifetime warranties. In most cases, the Company's vendors are primarily responsible for warranty claims. Warranty costs relating to merchandise sold under warranty not covered by vendors are estimated and recorded as warranty obligations at the time of sale based on each product's historical return rate. These obligations, which are often funded by vendor allowances, are recorded as a component of accrued expenses. For vendor allowances that are in excess of the related estimated warranty expense for the vendor's products, the excess is reclassified to inventory and recognized as a reduction to cost of sales as the related inventory is sold. The Company periodically assesses the adequacy of its recorded warranty liability and adjusts the amount as necessary resulting in income or expense recognition. The Company has successfully negotiated with certain vendors to transfer warranty obligations to such vendors in order to minimize the Company's warranty exposure resulting in credits to earnings of \$1.7 million in fiscal 2005, \$42.1 million in fiscal 2004, and \$8.7 million in fiscal 2003, and ongoing reductions in claim settlements. Changes in the Company's accrued sales and warranty returns for the last three fiscal years consisted of the following:

(in thousands)	Year Ended		
	August 27, 2005	August 28, 2004	August 30, 2003
Balance, beginning of fiscal year	\$ 11,493	\$ 78,482	\$ 82,035
Allowances received from vendors	53,997	49,444	116,808
Excess vendor allowances reclassified to inventory	(7,129)	(12,056)	—
Income	(1,736)	(42,094)	(25,522)
Claim settlements	(49,446)	(62,283)	(94,839)
Balance, end of fiscal year	\$ 7,179	\$ 11,493	\$ 78,482

**Note D—Income Taxes**

The provision for income tax expense for each of the last three fiscal years consisted of the following:

(in thousands)	Year Ended		
	August 27, 2005	August 28, 2004	August 30, 2003
Current:			
Federal	\$296,849	\$268,013	\$219,699
State	21,981	27,189	30,003
	318,830	295,202	249,702
Deferred:			
Federal	(11,271)	41,532	60,835
State	(5,357)	2,966	4,866
	(16,628)	44,498	65,701
	\$302,202	\$339,700	\$315,403

A reconciliation of the provision for income taxes to the amount computed by applying the federal statutory tax rate of 35% to income before income taxes is as follows:

(in thousands)	Year Ended		
	August 27, 2005	August 28, 2004	August 30, 2003
Expected tax at statutory rate	\$305,627	\$317,066	\$291,552
State income taxes, net	10,806	19,601	22,665
Tax benefit on repatriation of foreign earnings	(16,351)	—	—
Other	2,120	3,033	1,186
	\$302,202	\$339,700	\$315,403

The American Jobs Creation Act (the "Act"), signed into law in October 2004, provides an opportunity to repatriate foreign earnings, reinvest them in the United States, and claim an 85% dividend received deduction on the repatriated earnings provided certain criteria are met. The Company has determined that it meets the criteria of the Act, and it plans to repatriate all of its foreign earnings, approximately \$36.7 million, from its Mexico subsidiaries. As the Company had previously recorded deferred income taxes on these amounts, the planned repatriation resulted in a \$16.4 million one-time reduction to income tax expense for fiscal 2005.

Significant components of the Company's deferred tax assets and liabilities were as follows:

(in thousands)	August 27, 2005	August 28, 2004
<b>Net deferred tax assets:</b>		
Domestic net operating loss and credit carryforwards	\$19,589	\$ 30,775
Foreign net operating loss and credit carryforwards	2,298	8,597
Insurance reserves	12,470	23,584
Closed store reserves	3,317	4,437
Pension liability	26,792	7,322
Accrued benefits	6,451	5,398
Other	11,575	2,558
<b>Total deferred tax assets</b>	<b>82,492</b>	<b>82,671</b>
Less: Valuation allowances	(9,036)	(16,384)
<b>Net deferred tax assets</b>	<b>73,456</b>	<b>66,287</b>
<b>Deferred tax liabilities:</b>		
Property and equipment	12,221	25,000
Inventory	30,057	31,565
Derivatives	1,589	1,740
Prepaid expenses	7,630	7,610
Other	—	12,111
<b>Deferred tax liabilities</b>	<b>51,497</b>	<b>78,026</b>
<b>Net deferred tax assets (liabilities)</b>	<b>\$21,959</b>	<b>\$(11,739)</b>

For the years ended August 27, 2005 and August 28, 2004, the Company had deferred tax assets of \$9.2 million and \$9.4 million from federal tax net operating loss carryforwards ("NOLs") of \$26.3 million and \$26.9 million, and deferred tax assets of \$2.4 million and \$11.4 million from state tax NOLs of \$57.4 million and \$465.5 million, respectively. For the year ended August 28, 2004, the Company had deferred tax assets of \$5.7 million from foreign tax NOLs of \$16.8 million. The federal and state NOLs will expire between fiscal 2006 and fiscal 2024, and relate primarily to the acquisitions of ADAP, Inc. (which had been doing business as "Auto Palace") and Chief Auto Parts, Inc. in fiscal 1998. The Company maintains a \$7.6 million valuation allowance against certain federal and state NOLs subject to annual limitations resulting primarily from its acquisition of ADAP, Inc. This valuation allowance was recorded primarily as part of the ADAP, Inc. purchase accounting and, if reversed, will be allocated to goodwill. Additionally, the Company had deferred tax assets of \$10.2 million at August 27, 2005 and \$12.9 million at August 28, 2004, for federal, state, and Mexican income tax credit carryforwards. Certain tax credit carryforwards have no expiration date and others will expire in fiscal 2006 through fiscal 2014.

#### Note E—Financing

The Company's long-term debt as of August 27, 2005, and August 28, 2004, consisted of the following:

(in thousands)	August 27, 2005	August 28, 2004
Bank Term Loan due December 2009, effective interest rate of 4.55%	\$ 300,000	\$ —
5.875% Senior Notes due October 2012, effective interest rate of 6.33%	300,000	300,000
5.5% Senior Notes due November 2015, effective interest rate of 4.86%	300,000	300,000
4.75% Senior Notes due November 2010, effective interest rate of 4.17%	200,000	200,000
4.375% Senior Notes due June 2013, effective interest rate of 5.65%	200,000	200,000
6.5% Senior Notes due July 2008	190,000	190,000
7.99% Senior Notes due April 2006	150,000	150,000
Commercial paper, weighted average interest rate of 3.6% at August 27, 2005, and 1.6% at August 28, 2004	217,700	522,400
Other	4,150	6,850
	<b>\$1,861,850</b>	<b>\$1,869,250</b>

The Company maintains \$1.0 billion of revolving credit facilities with a group of banks. On May 3, 2005, the expiration dates of the facilities were extended by one year as permitted under the original agreement. Of the \$1.0 billion, \$300 million now expires in May 2006 and \$700 million now expires in May 2010. The credit facilities exist primarily to support commercial paper borrowings, letters of credit and other short-term unsecured bank loans. No amounts have been borrowed against the facilities, but as the available balance is reduced by commercial paper borrowings and certain outstanding letters of credit, the Company had \$661.2 million in available capacity under these facilities at August 27, 2005. The rate of interest payable under the credit facilities is a function of the London Interbank Offered Rate ("LIBOR"), the lending bank's base rate (as defined in the facility agreements) or a competitive bid rate at the option of the Company.

Commercial paper and other short-term borrowings are classified as long-term, as the Company has the ability and intent to refinance them on a long-term basis.

## Notes to Consolidated Financial Statements

(continued)

During November 2003, the Company issued \$300 million of 5.5% Senior Notes due November 2015 and \$200 million of 4.75% Senior Notes due November 2010. Interest under both notes is payable in May and November of each year. Proceeds were used to repay a \$250 million bank term loan, \$150 million in 6% Senior Notes and to reduce commercial paper borrowings. During November 2003, the Company settled all then outstanding interest rate hedge instruments, including interest rate swap contracts, treasury lock agreements and forward-starting interest rate swaps.

On August 17, 2004, the Company filed a shelf registration with the Securities and Exchange Commission that allows the Company to sell up to \$300 million in debt securities to fund general corporate purposes, including repaying, redeeming or repurchasing outstanding debt, and for working capital, capital expenditures, new store openings, stock repurchases and acquisitions. Based on changing market conditions, the Company chose to delay its issuance of debt securities and settled an outstanding forward-starting interest rate swap during November 2004.

On December 23, 2004, the Company entered into a credit agreement for a \$300 million, five-year term loan with a group of banks. The term loan consists of, at the Company's election, base rate loans, Eurodollar loans or a combination thereof. Interest accrues on base rate loans at a base rate per annum equal to the higher of prime rate or the Federal Funds Rate plus 1/2 of 1%. Interest accrues on Eurodollar loans at a defined Eurodollar rate plus the applicable percentage, which can range from 40 basis points to 112.5 basis points, depending upon the Company's senior unsecured (non-credit enhanced) long-term debt rating. At AutoZone's current ratings, the applicable percentage on Eurodollar loans is 50 basis points. On December 30, 2004, the full principal amount of \$300 million was funded as a Eurodollar loan. AutoZone may select interest periods of one, two, three or six months for Eurodollar loans, subject to availability. Interest is payable at the end of the selected interest period, but no less frequently than quarterly. AutoZone entered into an interest rate swap agreement to effectively fix, based on current debt ratings, the interest rate of the term loan at 4.55%. AutoZone has the option to extend loans into subsequent interest period(s) or convert them into loans of another interest rate type. The entire unpaid principal amount of the term loan will be due and payable in full on December 23, 2009, when the facility terminates. The Company may prepay the term loan in whole or in part at any time without penalty, subject to reimbursement of the lenders' breakage and redeployment costs in the case of prepayment of Eurodollar borrowings.

The Company agreed to observe certain covenants under the terms of its borrowing agreements, including limitations on total indebtedness, restrictions on liens and minimum fixed charge coverage. All of the repayment obligations under the Company's borrowing agreements may be accelerated and come due prior to the scheduled payment date if covenants are breached or an event of default occurs. Additionally, the repayment obligations may be accelerated if there is a change in control (as defined in the agreements) of AutoZone or its Board of Directors. As of August 27, 2005, the Company was in compliance with all covenants and expects to remain in compliance with all covenants.

All of the Company's debt is unsecured, except for \$4.2 million, which is collateralized by property. Scheduled maturities of long-term debt are as follows:

Fiscal Year	Amount (in thousands)
2006	\$ 370,450
2007	1,400
2008	190,000
2009	—
2010	300,000
Thereafter	<u>1,000,000</u>
	<u>\$1,861,850</u>

The maturities for fiscal 2006 are classified as long-term as the Company has the ability and intention to refinance them on a long-term basis.

The fair value of the Company's debt was estimated at \$1.868 billion as of August 27, 2005, and \$1.880 billion as of August 28, 2004, based on the quoted market prices for the same or similar issues or on the current rates available to the Company for debt of the same remaining maturities. Such fair value is greater than the carrying value of debt by \$6.3 million at August 27, 2005, and by \$11.1 million at August 28, 2004.

**Note F—Interest Expense**

Net interest expense for each of the last three fiscal years consisted of the following:

(in thousands)	Year Ended		
	August 27, 2005	August 28, 2004	August 30, 2003
Interest expense	<b>\$104,684</b>	\$93,831	\$86,635
Interest income	<b>(1,162)</b>	(214)	(1,054)
Capitalized interest	<b>(1,079)</b>	(813)	(791)
	<b>\$102,443</b>	\$92,804	\$84,790

**Note G—Stock Repurchase Program**

As of August 27, 2005, the Board of Directors had authorized the Company to repurchase up to \$4.4 billion of common stock in the open market. Such authorization includes the additional \$500 million that was approved by the Board of Directors on March 16, 2005. From January 1998 to August 27, 2005, the Company has repurchased a total of 87.0 million shares at an aggregate cost of \$4.1 billion. The following table summarizes our share repurchase activity for the following fiscal years:

(in thousands)	Year Ended		
	August 27, 2005	August 28, 2004	August 30, 2003
Amount	\$426,852	\$848,102	\$891,095
Shares	4,822	10,194	12,266

**Note H—Employee Stock Plans**

The Company has granted options to purchase common stock to some of its employees and directors under various plans at prices equal to the market value of the stock on the dates the options were granted. Options become exercisable in a one- to seven-year period, and expire ten years after the grant date. See "Note A—Significant Accounting Policies" for additional information regarding the Company's stock option plans. A summary of outstanding stock options is as follows:

	Number of Shares	Weighted Average Exercise Price
Outstanding August 31, 2002	6,284,559	\$30.09
Granted	1,475,922	71.55
Exercised	(1,763,940)	27.79
Canceled	(714,840)	32.00
Outstanding August 30, 2003	5,281,701	42.14
Granted	1,161,597	88.99
Exercised	(1,118,797)	32.16
Canceled	(312,795)	53.92
Outstanding August 28, 2004	5,011,706	54.42
Granted	1,099,465	77.74
Exercised	(1,741,312)	38.85
Canceled	(532,373)	70.91
<b>Outstanding August 27, 2005</b>	<b>3,837,486</b>	<b>\$65.87</b>

The following table summarizes information about stock options outstanding at August 27, 2005:

Range of Exercise Prices	Options Outstanding			Options Exercisable	
	Number Outstanding	Weighted Average Exercise Price	Weighted Average Remaining Contractual Life (in Years)	Number Exercisable	Weighted Average Exercise Price
\$20.12–\$43.90	1,069,307	\$31.30	4.40	736,616	\$30.32
\$45.53–\$71.12	808,647	70.03	6.95	339,302	68.82
\$71.17–\$74.42	61,875	72.48	6.77	26,000	72.73
\$75.64–\$75.64	820,700	75.64	9.09	—	—
\$80.14–\$98.30	1,076,957	89.23	8.26	207,198	88.99
\$20.12–\$98.30	3,837,486	\$65.87	7.06	1,309,116	\$50.42

Options to purchase 1.3 million shares at August 27, 2005, 1.7 million shares at August 28, 2004, and 1.5 million shares at August 30, 2003, were exercisable. Shares reserved for future grants were 2.5 million at August 27, 2005.

The Company also has an employee stock purchase plan, qualified under Section 423 of the Internal Revenue Code, under which all eligible employees may purchase AutoZone's common stock at 85% of the lower of the market price of the common stock on the first day or last day of each calendar quarter through payroll deductions. Maximum permitted annual purchases are \$15,000 per employee or 10 percent of compensation, whichever is less. Under the plan, 59,479 shares were sold to employees in fiscal 2005, 66,572 shares were sold in fiscal 2004, and 84,310 shares were sold in fiscal 2003. The Company repurchased, at fair value, 87,974 shares in fiscal 2005, 102,084 shares in fiscal 2004, and 134,972 shares in fiscal 2003 from employees electing to sell their stock. Issuances of shares under the employee stock purchase plans are netted against repurchases and such repurchases are not included in share repurchases disclosed in "Note G—Stock Repurchase Program." At August 27, 2005, 476,203 shares of common stock were reserved for future issuance under this plan.

The Amended and Restated Executive Stock Purchase Plan permits senior Company executives to purchase common stock up to 25 percent of their annual salary and bonus after the limits under the employee stock purchase plan have been exceeded. Purchases under this plan were 5,366 shares in fiscal 2005, 11,005 shares in fiscal 2004, and 18,524 shares in fiscal 2003. At August 27, 2005, 265,105 shares of common stock were reserved for future issuance under this plan.

Under the AutoZone, Inc. 2003 Director Compensation Plan, a non-employee director may receive no more than one-half of their director fees immediately in cash, and the remainder of the fees must be taken in common stock or may be deferred in units with value equivalent to the value of shares of common stock as of the grant date. At August 27, 2005, 90,769 shares of common stock were reserved for future issuance under this plan.

Under the AutoZone, Inc. 2003 Director Stock Option Plan, on January 1 of each year, each non-employee director receives an option to purchase 1,500 shares of common stock, and each non-employee director that owns common stock worth at least five times the annual fee paid to each non-employee director on an annual basis will receive an additional option to purchase 1,500 shares of common stock. In addition, each new director receives an option to purchase 3,000 shares upon election to the Board of Directors, plus a portion of the annual directors' option grant prorated for the portion of the year actually served in office. These stock option grants are made at the fair market value as of the grant date. At August 27, 2005, there were 64,617 outstanding options with 333,883 shares of common stock reserved for future issuance under this plan.

#### Note I—Pension and Savings Plans

Prior to January 1, 2003, substantially all full-time employees were covered by a defined benefit pension plan. The benefits under the plan were based on years of service and the employee's highest consecutive five-year average compensation. On January 1, 2003, the plan was frozen. Accordingly, pension plan participants will earn no new benefits under the plan formula and no new participants will join the pension plan.

On January 1, 2003, the Company's supplemental defined benefit pension plan for certain highly compensated employees was also frozen. Accordingly, plan participants will earn no new benefits under the plan formula and no new participants will join the pension plan.

The investment strategy for pension plan assets is to utilize a diversified mix of domestic and international equity portfolios, together with other investments, to earn a long-term investment return that meets the Company's pension plan obligations. Active management and alternative investment strategies are utilized within the plan in an effort to minimize risk, while realizing investment returns in excess of market indices. The weighted average asset allocation for our pension plan assets was as follows at June 30:

	2005		2004	
	Current	Target	Current	Target
Domestic equities	25.2%	32.0%	51.2%	50.0%
International equities	30.0	24.5	34.6	30.0
Alternative investments	31.6	30.5	10.9	13.0
Real estate	11.7	11.0	3.1	5.0
Cash and cash equivalents	1.5	2.0	0.2	2.0
	100.0%	100.0%	100.0%	100.0%

The Company makes annual contributions in amounts at least equal to the minimum funding requirements of the Employee Retirement Income Security Act of 1974. The Company made no contributions to the plans in fiscal 2005 or 2004 and contributed \$6.3 million to the plans in fiscal 2003. Based on current projections, we expect to contribute approximately \$7 million to the plan in fiscal 2006; however, a change in interest rates or expected return on plan assets may result in a change to the expected cash funding requirement in fiscal 2006. The measurement date for the Company's defined benefit pension plan is May 31 of each fiscal year.

The following table sets forth the plans' funded status and amounts recognized in the Company's financial statements:

(in thousands)	August 27, 2005	August 28, 2004
Change in benefit obligation:		
Benefit obligation at beginning of year	\$128,383	\$136,077
Interest cost	8,290	8,114
Actuarial losses (gains)	43,258	(13,070)
Benefits paid	(3,606)	(2,738)
Benefit obligation at end of year	176,325	128,383
Change in plan assets:		
Fair value of plan assets at beginning of year	102,361	86,737
Actual return on plan assets	9,568	19,157
Benefits paid	(3,606)	(2,738)
Administrative expenses	(772)	(795)
Fair value of plan assets at end of year	107,551	102,361
Reconciliation of funded status:		
Underfunded status of the plans	(68,774)	(26,022)
Unrecognized net actuarial losses	62,264	20,690
Unamortized prior service cost	(522)	(1,166)
Accrued benefit cost	\$ (7,032)	\$ (6,498)
Recognized defined benefit pension liability:		
Accrued benefit liability	\$ (68,774)	\$ (26,022)
Accumulated other comprehensive income	61,742	19,524
Net liability recognized	\$ (7,032)	\$ (6,498)

(in thousands)	Year Ended		
	August 27, 2005	August 28, 2004	August 30, 2003
Components of net periodic benefit cost:			
Service cost	\$ —	\$ —	\$ 4,823
Interest cost	8,290	8,114	6,214
Expected return on plan assets	(8,107)	(6,871)	(6,609)
Amortization of prior service cost	(644)	(645)	(575)
Recognized net actuarial losses	1,000	4,371	—
Curtailment gain	—	—	(107)
Net periodic benefit cost	\$ 539	\$ 4,969	\$ 3,746

The actuarial assumptions were as follows:

	2005	2004	2003
Weighted average discount rate	5.25%	6.50%	6.00%
Expected long-term rate of return on assets	8.00%	8.00%	8.00%

As the plan benefits were frozen as of December 31, 2002, increases in future compensation levels no longer impact the calculation. In fiscal year 2003, the assumed increases in future compensation levels were generally age weighted rates from 5–10% after the first two years of service using 15% for year one and 12% for year two. Moody's Aa rates as of the measurement date are used as a guide in establishing the weighted average discount rate. The expected long-term rate of return on plan assets is based on the historical relationships between the investment classes and the capital markets, updated for current conditions. Prior service cost is amortized over the estimated average remaining service lives of the plan participants and the unrecognized actuarial loss is amortized over the remaining service period of 7.88 years at August 27, 2005.

Actual benefit payments may vary significantly from the following estimates. Based on current assumptions about future events, benefit payments are expected to be paid as follows for each of the following plan years:

Plan Year Ending December 31	Amount (in thousands)
2005	\$ 2,532
2006	2,963
2007	3,489
2008	4,113
2009	4,680
2010–2014	31,834

*Notes to Consolidated Financial Statements*  
(continued)

On January 1, 2003, the Company introduced an enhanced defined contribution plan ("401(k) plan") pursuant to Section 401(k) of the Internal Revenue Code that replaced the previous 401(k) plan. The 401(k) plan covers substantially all employees that meet the plan's service requirements. The new plan features include increased Company matching contributions, immediate 100% vesting of Company contributions and an increased savings option to 25% of qualified earnings. The Company makes matching contributions, per pay period, up to a specified percentage of employees' contributions as approved by the Board of Directors. The Company made matching contributions to employee accounts in connection with the 401(k) plan of \$8.4 million in fiscal 2005, \$8.8 million in fiscal 2004, and \$4.5 million in fiscal year 2003.

**Note J—Leases**

Some of the Company's retail stores, distribution centers and equipment are leased. Most of these leases include renewal options, at the Company's election, and some include options to purchase and provisions for percentage rent based on sales. Rental expense was \$150.6 million in fiscal 2005, \$116.9 million in fiscal 2004, and \$110.7 million in fiscal 2003. Percentage rentals were insignificant.

Based on recent clarifications from the Securities and Exchange Commission, the Company completed a detailed review of its accounting for rent expense and expected useful lives of leasehold improvements. The Company noted inconsistencies in the periods used to amortize leasehold improvements and the periods used to straight-line rent expense. The Company has revised its policy to record rent for all operating leases on a straight-line basis over the lease term, including any reasonably assured renewal periods and the period of time prior to the lease term that the Company is in possession of the leased space for the purpose of installing leasehold improvements. Differences between recorded rent expense and cash payments are recorded as a liability in accrued expenses and other long-term liabilities on the balance sheet. This deferred rent approximated \$27.9 million on August 27, 2005. Additionally, all leasehold improvements are amortized over the lesser of their useful life or the remainder of the lease term, including any reasonably assured renewal periods, in effect when the leasehold improvements are placed in service. During the quarter ended February 12, 2005, the Company recorded an adjustment in the amount of \$40.3 million pre-tax (\$25.4 million after-tax), which included the impact on prior years, to reflect additional amortization of leasehold improvements and additional rent expense as if this new policy had always been followed by the Company. The impact of the adjustment on any prior year and the impact of the cumulative adjustment on the current year is immaterial.

Minimum annual rental commitments under non-cancelable operating leases were as follows at the end of fiscal 2005:

Fiscal Year	Amount (in thousands)
2006	\$141,169
2007	126,651
2008	107,223
2009	86,473
2010	70,516
Thereafter	435,293
Total minimum payments required	<u>\$967,325</u>

In connection with the Company's December 2001 sale of the TruckPro business, the Company subleased some properties to the purchaser for an initial term of not less than 20 years. The Company's remaining aggregate rental obligation at August 27, 2005 of \$28.5 million is included in the above table, but the obligation is entirely offset by the sublease rental agreement.

**Note K—Restructuring and Closed Store Obligations**

From time to time, the Company will close under-performing leased stores. The remaining minimum lease obligations and other carrying costs of these properties are accrued upon the store closing. The following table presents a summary of the closed store obligations including those obligations originating from the 2001 restructuring and all other store closings:

(in thousands)	Fiscal Year Ended		
	August 27, 2005	August 28, 2004	August 30, 2003
Beginning balance	\$11,186	\$ 26,838	\$ 52,472
Increase to reserve	728	2,610	3,748
Payment of obligations	(2,755)	(13,429)	(14,736)
Adjustment gains	(1,000)	(4,833)	(4,646)
Other reserve reductions	—	—	(10,000)
Ending balance	<u>\$ 8,159</u>	<u>\$ 11,186</u>	<u>\$ 26,838</u>

Increases to the reserve represent the accrual for stores closed during the period and the accretion of interest expense on the discounting of the remaining lease obligations. Adjustment gains represent reversals of amounts previously reserved due to the subsequent development, negotiated lease buy-out or disposition of properties. Other reserve deductions represent adjustments to liabilities established in the purchase accounting of acquisitions. These reserve reductions were recorded as a reduction to the goodwill balances associated with the related acquisitions.



In December 2001, TruckPro was sold to a group of investors for cash proceeds of \$25.7 million and a promissory note. The Company had deferred a gain of \$3.6 million related to the sale due to uncertainties associated with the realization of the gain. During fiscal 2003, the note (with a face value of \$4.5 million) was repaid to the Company and certain liabilities were settled. As a result, a total gain of \$4.7 million was recognized into income during fiscal 2003.

#### Note L—Commitments and Contingencies

Construction commitments, primarily for new stores, totaled approximately \$47.9 million at August 27, 2005.

The Company had \$121.2 million in outstanding letters of credit and \$13.4 million in surety bonds as of August 27, 2005, which all have expiration periods of less than one year. A substantial portion of the outstanding standby letters of credit (which are primarily renewed on an annual basis) and surety bonds are used to cover reimbursement obligations to our workers' compensation carriers. There are no additional contingent liabilities associated with these instruments as the underlying liabilities are already reflected in our balance sheet. The letters of credit and surety bonds arrangements have automatic renewal clauses.

#### Note M—Litigation

AutoZone, Inc. is a defendant in a lawsuit entitled "Coalition for a Level Playing Field, L.L.C., et al., v. AutoZone, Inc. et al.," filed in the U.S. District Court for the Southern District of New York in October 2004. The case was filed by approximately 240 plaintiffs, which are principally automotive aftermarket warehouse distributors and jobbers, against 24 defendants, 11 of which are principally automotive aftermarket retailers and 13 of which are principally aftermarket manufacturers. One aftermarket retailer was subsequently dismissed, leaving 10 aftermarket retailer defendants, and 6 aftermarket manufacturers subsequently settled, were dismissed, or were improperly served, leaving 7 aftermarket manufacturer defendants, for a current total of 17 remaining defendants ("Defendants"). The plaintiffs allege, inter alia, that the automotive aftermarket retailer defendants have conspired with the aftermarket manufacturer defendants to receive benefits such as volume discounts, rebates, early buy allowances and other allowances, fees, inventory without payment, sham advertising and promotional payments, a share in the manufacturers' profits and excessive payments for services purportedly performed for the manufacturers in violation of the Robinson-Patman Act and the Sherman Act (collectively, the "Acts"). Additionally, a subset of plaintiffs alleges a claim of fraud against the automotive aftermarket retailer defendants based on discovery issues in a prior litigation involving similar Robinson-Patman Act claims. In the prior litigation, the discovery dispute, as well as the underlying claims, were decided in favor of AutoZone and the other automotive aftermarket retailer defendants who proceeded to trial, pursuant to a unanimous jury verdict which was affirmed by the Second Circuit Court of Appeals. In the current litigation, plaintiffs seek an unspecified amount of damages (including statutory trebling), attorneys' fees, and a permanent injunction prohibiting the aftermarket retailer defendants from inducing and/or knowingly receiving discriminatory prices from any of the aftermarket manufacturer defendants and from opening up any further stores to compete with plaintiffs as long as defendants allegedly continue to violate the Acts. The Company believes this suit to be without merit and is vigorously defending against it. In August 2005, the Defendants filed two motions to dismiss all claims with prejudice on substantive and procedural grounds, which if granted in their entirety, would resolve the litigation in Defendants' favor. Additionally, the Defendants are seeking to enjoin plaintiffs from filing similar lawsuits in the future.

On June 22, 2005, the Attorney General of the State of California, in conjunction with District Attorneys for San Bernardino, San Joaquin and Monterey Counties, filed suit in the San Bernardino County Superior Court against AutoZone, Inc. and its California subsidiaries. The San Diego County District Attorney later joined the suit. The lawsuit alleges that AutoZone failed to follow various state statutes and regulations governing the storage and handling of used motor oil and other materials collected for recycling or used for cleaning AutoZone stores and parking lots. The suit seeks \$12.0 million in penalties and injunctive relief.

The Company currently, and from time to time, is involved in various other legal proceedings incidental to the conduct of its business. Although the amount of liability that may result from these other proceedings cannot be ascertained, the Company does not currently believe that, in the aggregate, these matters will result in liabilities material to the Company's financial condition, results of operations or cash flows.

#### Note N—Segment Reporting

The Company manages its business on the basis of one reportable segment. See "Note A—Significant Accounting Policies" for a brief description of the Company's business. As of August 27, 2005, the majority of the Company's operations were located within the United States. Other operations include ALLDATA and the Mexico locations, each of which comprises less than 3% of consolidated net sales. The following data is presented in accordance with Statement of Financial Accounting Standards No. 131, "Disclosures about Segments of an Enterprise and Related Information":

(in thousands)	Year Ended		
	August 27, 2005	August 28, 2004	August 30, 2003
Primary business focus:			
U.S. Retail	\$4,795,648	\$4,727,402	\$4,638,361
Commercial	718,150	740,480	670,010
Other	197,084	169,143	148,752
Net sales	\$5,710,882	\$5,637,025	\$5,457,123

**Officers****Customer Satisfaction**

William C. Rhodes, III  
President and Chief Executive Officer

**Executive Vice Presidents**

Bradley W. Bacon†  
Store Operations and Commercial

Harry L. Goldsmith†  
General Counsel and Secretary

Robert D. Olsen†  
Supply Chain, Information Technology,  
Mexico and Store Development

James A. Shea†  
Merchandising and Marketing

**Senior Vice Presidents**

Timothy W. Briggs†  
Human Resources

Lisa R. Kranc†  
Marketing

†Required to file under Section 16 of the Securities  
Exchange Act of 1934.

**Vice Presidents**

Craig L. Barnes  
Merchandising

L. Dan Barzel  
Merchandising

Jon A. Bascom  
Information Technology

Rebecca W. Ballou  
Assistant General Counsel and  
Assistant Secretary

B. Craig Blackwell  
Operations

Kenneth L. Brame  
Chief Information Officer

Michael T. Broderick  
Operations

Brian L. Campbell  
Investor Relations and Tax

James A. Cook, III  
Treasurer

Phil Daniele  
Operations

Brett D. Easley  
Merchandise Pricing and Analysis

Mark A. Finestone  
Merchandising

Wm. David Gilmore  
Store Development

Eric S. Gould  
Commercial

William W. Graves  
Supply Chain

William R. Hackney  
Operations

Larry J. Hardy  
Tax

Diana H. Hull  
Assistant General Counsel and  
Assistant Secretary

Jeffrey W. Lagges  
ALLDATA

Jose Marrero  
Marketing

Richard McDuffie  
Supply Chain

Grant McGee  
Operations

Thomas Newbern  
Operations

Charlie Pleas, III†  
Controller

Raymond Pohlman  
Government Relations and Media

Elizabeth Rabun  
Loss Prevention

Anthony Dean Rose, Jr.  
Merchandising

Michael L. Shadrach  
Strategic Planning and  
New Business Development

Brett L. Shanaman  
Marketing

Richard C. Smith  
Operations

Scott W. Webb  
Merchandising

**Transfer Agent and Registrar**

Computershare Investor Services  
P.O. Box 43069  
Providence, Rhode Island 02940-3069  
(877) 282-1168  
(781) 575-2723  
<http://www.computershare.com>

**Annual Meeting**

The Annual Meeting of Stockholders of  
AutoZone will be held at 8:30 a.m., CST,  
on December 14, 2005, at the J.R. Hyde,  
III Store Support Center, 123 South Front Street,  
Memphis, Tennessee.

**AutoZone Web Sites**

Investor Relations: <http://www.autozoneinc.com>  
Company Web Site: <http://www.autozone.com>

**Stock Exchange Listing**

New York Stock Exchange  
Ticker Symbol: AZO

**Auditors**

Ernst & Young LLP  
Memphis, Tennessee

**Code of Ethical Conduct**

AutoZone's Code of Ethical Conduct is  
available on its investor relations Web site  
at <http://www.autozoneinc.com>.

**Form 10-K/Quarterly Reports**

Stockholders may obtain free of charge a copy  
of AutoZone's annual report on Form 10-K, its  
quarterly reports on Form 10-Q as filed with  
the Securities and Exchange Commission and  
quarterly press releases by contacting Investor  
Relations, P.O. Box 2198, Memphis, Tennessee  
38101; e-mailing [investor.relations@autozone.com](mailto:investor.relations@autozone.com)  
or phoning (901) 495-7185.

Copies of all documents filed by AutoZone  
with the Securities and Exchange Commission,  
including Form 10-K and Form 10-Q, are  
also available at the SEC's EDGAR server  
at <http://www.sec.gov>.

**Stockholders of Record**

As of August 27, 2005, there were 3,586 stock-  
holders of record, excluding the number of ben-  
eficial owners whose shares were represented  
by security position listings.

**Board of Directors**

Charles M. Elson<sup>(3)</sup>  
Edgar S. Woolard Jr.  
Professor of Corporate Governance  
University of Delaware

Sue E. Gove<sup>(1)</sup>  
Executive Vice President and COO  
Zale Corporation

Earl G. Graves, Jr.<sup>(1,3)</sup>  
President and COO  
Earl G. Graves Publishing

Dr. N. Gerry House<sup>(2)</sup>  
President and CEO  
Institute for Student Achievement

J. R. Hyde, III  
Chairman  
AutoZone, Inc.

Edward S. Lampert<sup>(2)</sup>  
Chairman and CEO  
ESL Investments, Inc.

W. Andrew McKenna<sup>(1\*,2)</sup>  
Private Investor

William C. Rhodes, III  
President and CEO  
AutoZone, Inc.

(1) Audit Committee  
(2) Compensation Committee  
(3) Nominating and Corporate  
Governance Committee  
\* Committee Chair



Charles M. Elson



Sue E. Gove



Earl G. Graves, Jr.



Dr. N. Gerry House



J. R. Hyde, III



Edward S. Lampert



W. Andrew McKenna



William C. Rhodes, III

In *Fortune* magazine's recent *75th Anniversary Special Issue*, AutoZone was recognized as one of the top ten organizations across America that believe "customer service is an ethos to be lived—imbuing the often thankless task of pleasing customers with an almost spiritual sense of mission." While we beg to differ with *Fortune's* characterization of helping customers as thankless, we're extremely proud to be recognized as having this unique trait. AutoZone was built on customer service, and we look forward to sharing our knowledge on vehicle solutions with our customers for many years to come.



**AutoZone continues to be an amazing success story in American business history. We enjoy industry leading earnings and returns on capital. It is an honor to share our successes and future plans with you, our customers, AutoZoners, and stockholders who continue to have confidence in us. We look forward to sharing with you our future successes.**



123 South Front Street  
Memphis, Tennessee 38103-3607  
(901) 495-6500  
[www.autozone.com](http://www.autozone.com)