

UNITED STATES  
SECURITIES AND EXCHANGE COMMISSION  
Washington, D.C. 20549

FORM C/A

UNDER THE SECURITIES ACT OF 1933

(Mark one.)

- Form C: Offering Statement  
 Form C-U: Progress Update  
 Form C/A: Amendment to Offering Statement  
     Check box if Amendment is material and investors must reconfirm within five business days.  
    This non-material amendment is filed to note the change in Escrow Agent.  
 Form C-AR: Annual Report  
 Form C-AR/A: Amendment to Annual Report  
 Form C-TR: Termination of Reporting

***Name of Issuer:***

Quick Loadz Container System, LLC

***Legal status of Issuer:***

***Form:***

LLC

***Jurisdiction of Incorporation/Organization:***

Ohio

***Date of Organization:***

April 5, 2013

***Physical Address of Issuer:***

5850 Industrial Drive, Athens, OH 45701, United States

***Website of Issuer:***

<https://quickloadz.com>

***Is there a Co-Issuer? \_\_\_ Yes \_X\_ No***

***Name of Intermediary through which the Offering will be Conducted:***

OpenDeal Portal LLC dba Republic

***CIK Number of Intermediary:***

0001751525

***SEC File Number of Intermediary:***

007-00167

***CRD Number of Intermediary:***

283874

***Name of qualified third party "Escrow Agent" which the Offering will utilize:***

Prime Trust, LLC

***Amount of compensation to be paid to the intermediary, whether as a dollar amount or a percentage of the offering amount, or a good faith estimate if the exact amount is not available at the time of the filing, for conducting the offering, including the amount of referral and any other fees associated with the offering:***

At the conclusion of the offering, the issuer shall pay a fee of six percent (6%) of the amount raised in the offering to the Intermediary.

***Any other direct or indirect interest in the issuer held by the intermediary, or any arrangement for the intermediary to acquire such an interest:***

The Intermediary will also receive compensation in the form of securities equal to two percent (2%) of the total number of the securities sold in the offering.

***Type of Security Offered:***

Crowd SAFE (Simple Agreement for Future Equity)

***Target Number of Securities to be Offered:***

25,000

***Price (or Method for Determining Price):***

\$1.00

***Target Offering Amount:***

\$25,000

***Oversubscriptions Accepted:***

Yes

No

***Oversubscriptions will be Allocated:***

Pro-rata basis

First-come, first-served basis

Other: At the Intermediary's discretion

***Maximum offering amount (if different from Target Offering Amount):***

\$1,070,000

***Deadline to reach the Target Offering Amount:***

April 18, 2022



**If the sum of the investment commitments does not equal or exceed the target offering amount at the deadline to reach the target offering amount, no Securities will be sold in the offering, investment commitments will be cancelled and committed funds will be returned.**

***Current Number of Employees:***

20

	<b>Most recent fiscal year-end (2020)</b>	<b>Prior fiscal year-end (2019)</b>
<b>Total Assets</b>	\$2,240,087	\$2,117,907
<b>Cash &amp; Cash Equivalents</b>	\$182,122	\$913,107
<b>Accounts Receivable</b>	\$3,087	\$0
<b>Short-term Debt</b>	\$568,124	\$344,329
<b>Long-term Debt</b>	\$2,466,157	\$2,784,644
<b>Revenues/Sales</b>	\$1,002,474	\$703,706
<b>Cost of Goods Sold</b>	\$687,266	\$511,559
<b>Taxes Paid</b>	\$0	\$0
<b>Net Income/(Net Loss)</b>	\$130,062	\$(497,420)

***The jurisdictions in which the issuer intends to offer the securities:***

Alabama, Alaska, Arizona, Arkansas, California, Colorado, Connecticut, Delaware, District Of Columbia, Florida, Georgia, Guam, Hawaii, Idaho, Illinois, Indiana, Iowa, Kansas, Kentucky, Louisiana, Maine, Maryland, Massachusetts, Michigan, Minnesota, Mississippi, Missouri, Montana, Nebraska, Nevada, New Hampshire, New Jersey, New Mexico, New York, North Carolina, North Dakota, Ohio, Oklahoma, Oregon, Pennsylvania, Puerto Rico, Rhode Island, South Carolina, South Dakota, Tennessee, Texas, Utah, Vermont, Virgin Islands, U.S., Virginia, Washington, West Virginia, Wisconsin, Wyoming, American Samoa, and Northern Mariana Islands

March 28, 2022

Quick Loadz Container System, LLC



Up to \$1,070,000 of Crowd SAFE (Simple Agreement for Future Equity)

Quick Loadz Container System, LLC (“QuickLoadz,” the “Company,” “we,” “us,” or “our”), is offering a minimum amount of \$25,000 (the “Target Offering Amount”) and up to a maximum amount of \$1,070,000 (the “Maximum Offering Amount”) of Crowd SAFE (Simple Agreement for Future Equity) (the “Securities”) on a best-efforts basis as described in this Form C/A (this “Offering”). We must raise an amount equal to or greater than the Target Offering Amount by April 18, 2022 (the “Offering Deadline”). Unless we receive investment commitments, which are fully paid for and meet all other requirements set by this Offering, in an amount not less than the Target Offering Amount by the Offering Deadline, no Securities will be sold in this Offering, all investment commitments will be cancelled, and all committed funds will be returned.

Potential purchasers of the Securities are referred to herein as “Investors” or “you”. The rights and obligations of Investors with respect to the Securities are set forth below in the section titled “The Offering and the Securities—The Securities”. In order to purchase the Securities, you must complete the purchase process through our intermediary, OpenDeal Portal LLC dba Republic (the “Intermediary”). All committed funds will be held in escrow with Prime Trust, LLC (the “Escrow Agent”) until the Target Offering Amount has been met or exceeded and one or more closings occur. Investors may cancel an investment commitment until up to 48 hours prior to the Offering Deadline, or such earlier time as the Company designates pursuant to Regulation CF, using the cancellation mechanism provided by the Intermediary.

Investment commitments may be accepted or rejected by us, in our sole and absolute discretion. We have the right to cancel or rescind our offer to sell the Securities at any time and for any reason. The Intermediary has the ability to reject any investment commitment and may cancel or rescind our offer to sell the Securities at any time for any reason.

	Price to Investors	Service Fees and Commissions (1)(2)	Net Proceeds
Minimum Individual Purchase Amount (3)	\$150	\$9.00	\$141.00
Maximum Individual Purchase Amount (3)(4)	\$107,000	\$6,420	\$100,580
Target Offering Amount	\$25,000	\$1,500	\$23,500
Maximum Offering Amount	\$1,070,000	\$64,200	\$1,005,800

- (1) This excludes fees to Company’s advisors, such as attorneys and accountants.
- (2) In addition to the six percent (6%) fee shown here, the Intermediary will also receive a securities commission equal to two percent (2%) of the Securities sold in this Offering.
- (3) The Company reserves the right to amend the Minimum Individual Purchase Amount and Maximum Individual Purchase Amount, in its sole discretion. In particular, the Company may elect to

- participate in one of the Intermediary's special investment programs and may offer alternative Minimum Individual Purchase Amounts and Maximum Individual Purchase Amounts to Investors participating in such programs without notice.
- (4) Subject to any other investment amount limitations applicable to the Investor under Regulation CF.

**A crowdfunding investment involves risk. You should not invest any funds in this Offering unless you can afford to lose your entire investment.**

**In making an investment decision, investors must rely on their own examination of the Company and the terms of the Offering, including the merits and risks involved. These Securities have not been recommended or approved by any federal or state securities commission or regulatory authority. Furthermore, these authorities have not passed upon the accuracy or adequacy of this document.**

**The U.S. Securities and Exchange Commission does not pass upon the merits of any Securities offered or the terms of the Offering, nor does it pass upon the accuracy or completeness of any Offering document or literature.**

**These Securities are offered under an exemption from registration; however, the U.S. Securities and Exchange Commission has not made an independent determination that these Securities are exempt from registration.**

THESE SECURITIES INVOLVE A HIGH DEGREE OF RISK THAT MAY NOT BE APPROPRIATE FOR ALL INVESTORS. THERE ARE ALSO SIGNIFICANT UNCERTAINTIES ASSOCIATED WITH AN INVESTMENT IN OUR COMPANY AND THE SECURITIES. THE SECURITIES OFFERED HEREBY ARE NOT PUBLICLY TRADED. THERE IS NO PUBLIC MARKET FOR THE SECURITIES AND ONE MAY NEVER DEVELOP. AN INVESTMENT IN OUR COMPANY IS HIGHLY SPECULATIVE. THE SECURITIES SHOULD NOT BE PURCHASED BY ANYONE WHO CANNOT BEAR THE FINANCIAL RISK OF THIS INVESTMENT FOR AN INDEFINITE PERIOD OF TIME AND WHO CANNOT AFFORD THE LOSS OF THEIR ENTIRE INVESTMENT. SEE THE SECTION OF THIS FORM C/A TITLED "*RISK FACTORS*" BEGINNING ON PAGE 2.

THE SECURITIES OFFERED HEREBY WILL HAVE TRANSFER RESTRICTIONS. NO SECURITIES MAY BE PLEDGED, TRANSFERRED, RESOLD OR OTHERWISE DISPOSED OF BY ANY INVESTOR EXCEPT PURSUANT TO RULE 501 OF REGULATION CF. YOU SHOULD BE AWARE THAT YOU WILL BE REQUIRED TO BEAR THE FINANCIAL RISKS OF THIS INVESTMENT FOR AN INDEFINITE PERIOD OF TIME.

YOU ARE NOT TO CONSTRUE THE CONTENTS OF THIS FORM C/A AS LEGAL, ACCOUNTING OR TAX ADVICE OR AS INFORMATION NECESSARILY APPLICABLE TO YOUR PARTICULAR FINANCIAL SITUATION. EACH INVESTOR SHOULD CONSULT THEIR OWN FINANCIAL ADVISER, COUNSEL AND ACCOUNTANT AS TO LEGAL, TAX AND RELATED MATTERS CONCERNING THEIR INVESTMENT.

THIS OFFERING IS ONLY EXEMPT FROM REGISTRATION UNDER THE LAWS OF THE UNITED STATES AND ITS TERRITORIES. NO OFFER IS BEING MADE IN ANY JURISDICTION NOT LISTED ABOVE. PROSPECTIVE INVESTORS ARE SOLELY RESPONSIBLE FOR DETERMINING THE PERMISSIBILITY OF THEIR PARTICIPATING IN THIS OFFERING, INCLUDING OBSERVING ANY OTHER REQUIRED LEGAL FORMALITIES AND SEEKING CONSENT FROM THEIR LOCAL REGULATOR, IF NECESSARY. THE INTERMEDIARY FACILITATING THIS OFFERING IS LICENSED AND REGISTERED SOLELY IN THE UNITED STATES AND HAS NOT SECURED, AND HAS NOT SOUGHT TO SECURE, A LICENSE OR WAIVER OF THE NEED FOR SUCH LICENSE IN ANY OTHER JURISDICTION. THE COMPANY, THE ESCROW AGENT AND THE INTERMEDIARY, EACH RESERVE THE RIGHT TO REJECT ANY INVESTMENT COMMITMENT MADE BY ANY PROSPECTIVE INVESTOR, WHETHER FOREIGN OR DOMESTIC.

#### **SPECIAL NOTICE TO FOREIGN INVESTORS**

IF YOU LIVE OUTSIDE THE UNITED STATES, IT IS YOUR RESPONSIBILITY TO FULLY OBSERVE THE LAWS OF ANY RELEVANT TERRITORY OR JURISDICTION OUTSIDE THE UNITED STATES IN CONNECTION WITH ANY PURCHASE OF THE SECURITIES, INCLUDING OBTAINING REQUIRED GOVERNMENTAL OR OTHER CONSENTS OR OBSERVING ANY OTHER REQUIRED LEGAL OR OTHER

FORMALITIES. WE RESERVE THE RIGHT TO DENY THE PURCHASE OF THE SECURITIES BY ANY FOREIGN INVESTOR.

### **NOTICE REGARDING THE ESCROW AGENT**

PRIME TRUST, LLC, THE ESCROW AGENT SERVICING THE OFFERING, HAS NOT INVESTIGATED THE DESIRABILITY OR ADVISABILITY OF AN INVESTMENT IN THIS OFFERING OR THE SECURITIES OFFERED HEREIN. THE ESCROW AGENT MAKES NO REPRESENTATIONS, WARRANTIES, ENDORSEMENTS, OR JUDGMENT ON THE MERITS OF THE OFFERING OR THE SECURITIES OFFERED HEREIN. THE ESCROW AGENT'S CONNECTION TO THE OFFERING IS SOLELY FOR THE LIMITED PURPOSES OF ACTING AS A SERVICE PROVIDER.

The Company has certified that all of the following statements are TRUE for the Company in connection with this Offering:

- (1) Is organized under, and subject to, the laws of a State or territory of the United States or the District of Columbia;
- (2) Is not subject to the requirement to file reports pursuant to Section 13 or Section 15(d) of the Securities Exchange Act of 1934 (the "**Exchange Act**") (15 U.S.C. 78m or 78o(d));
- (3) Is not an investment company, as defined in Section 3 of the Investment Company Act of 1940 (the "**Investment Company Act**") (15 U.S.C. 80a-3), or excluded from the definition of investment company by Section 3(b) or Section 3(c) of the Investment Company Act (15 U.S.C. 80a-3(b) or 80a-3(c));
- (4) Is not ineligible to offer or sell securities in reliance on Section 4(a)(6) of the Securities Act of 1933 (the "**Securities Act**") (15 U.S.C. 77d(a)(6)) as a result of a disqualification as specified in § 227.503(a);
- (5) Has filed with the SEC and provided to investors, to the extent required, any ongoing annual reports required by law during the two years immediately preceding the filing of this Form C/A; and
- (6) Has a specific business plan, which is not to engage in a merger or acquisition with an unidentified company or companies.

### **Bad Actor Disclosure**

The Company is not subject to any bad actor disqualifications under any relevant U.S. securities laws.

### **Ongoing Reporting**

Following the first sale of the Securities, the Company will file a report electronically with the Securities and Exchange Commission annually and post the report on its website, no later than 120 days after the end of the Company's fiscal year.

Once posted, the annual report may be found on the Company's website at <https://quickloadz.com>.

The Company must continue to comply with the ongoing reporting requirements until:

- (1) the Company is required to file reports under Section 13(a) or Section 15(d) of the Exchange Act;
- (2) the Company has filed at least three annual reports pursuant to Regulation CF and has total assets that do not exceed \$10,000,000;
- (3) the Company has filed at least one annual report pursuant to Regulation CF and has fewer than 300 holders of record;
- (4) the Company or another party repurchases all of the Securities issued in reliance on Section 4(a)(6) of the Securities Act, including any payment in full of debt securities or any complete redemption of redeemable securities; or
- (5) the Company liquidates or dissolves its business in accordance with applicable state law.

Neither the Company nor any of its predecessors (if any) previously failed to comply with the ongoing reporting requirement of Regulation CF.

**Updates**

Updates on the status of this Offering may be found at: <https://www.republic.com/quick-loadz>

The date of this Form C/A is March 28, 2022.

## TABLE OF CONTENTS

ABOUT THIS FORM C/A .....	i
CAUTIONARY NOTE CONCERNING FORWARD-LOOKING STATEMENTS .....	i
SUMMARY .....	1
The Company .....	1
The Offering .....	1
RISK FACTORS .....	2
Risks Related to the Company’s Business and Industry .....	2
Risks Related to the Offering .....	6
Risks Related to the Securities .....	7
BUSINESS .....	11
Description of the Business .....	11
Business Plan .....	11
The Company’s Products and/or Services .....	11
Competition .....	15
Customer Base .....	15
Intellectual Property .....	16
Governmental/Regulatory Approval and Compliance .....	17
Litigation .....	17
USE OF PROCEEDS .....	18
DIRECTORS, OFFICERS, MANAGERS AND KEY PERSONS .....	19
Indemnification .....	19
Employees .....	19
CAPITALIZATION, DEBT AND OWNERSHIP .....	20
Capitalization .....	20
Outstanding Debt .....	21
Ownership .....	22
FINANCIAL INFORMATION .....	23
Operations .....	23
Cash and Cash Equivalents .....	23
Liquidity and Capital Resources .....	23
Capital Expenditures and Other Obligations .....	23
Valuation .....	23
Material Changes and Other Information .....	23
Previous Offerings of Securities .....	24
TRANSACTIONS WITH RELATED PERSONS AND CONFLICTS OF INTEREST .....	24
THE OFFERING AND THE SECURITIES .....	25
The Offering .....	25
The Securities .....	26
COMMISSION AND FEES .....	30
Stock, Warrants and Other Compensation .....	30
TAX MATTERS .....	30
LEGAL MATTERS .....	30
DISCLAIMER OF TELEVISION, RADIO, PODCAST AND STREAMING PRESENTATION .....	30
ADDITIONAL INFORMATION .....	31

## **ABOUT THIS FORM C/A**

You should rely only on the information contained in this Form C/A. We have not authorized anyone to provide any information or make any representations other than those contained in this Form C/A, and no source other than the Intermediary has been authorized to host this Form C/A and the Offering. If anyone provides you with different or inconsistent information, you should not rely on it. We are not offering to sell, nor seeking offers to buy, the Securities in any jurisdiction where such offers and sales are not permitted. The information contained in this Form C/A and any documents incorporated by reference herein is accurate only as of the date of those respective documents, regardless of the time of delivery of this Form C/A or the time of issuance or sale of any Securities.

Statements contained herein as to the content of any agreements or other documents are summaries and, therefore, are necessarily selective and incomplete and are qualified in their entirety by the actual agreements or other documents. Prior to the consummation of the purchase and sale of the Securities, the Company will afford prospective Investors an opportunity to ask questions of, and receive answers from, the Company and its management concerning the terms and conditions of this Offering and the Company.

In making an investment decision, you must rely on your own examination of the Company and the terms of the Offering, including the merits and risks involved. The statements of the Company contained herein are based on information believed to be reliable; however, no warranty can be made as to the accuracy of such information or that circumstances have not changed since the date of this Form C/A. For example, our business, financial condition, results of operations, and prospects may have changed since the date of this Form C/A. The Company does not expect to update or otherwise revise this Form C/A or any other materials supplied herewith.

This Form C/A is submitted in connection with the Offering described herein and may not be reproduced or used for any other purpose.

### **CAUTIONARY NOTE CONCERNING FORWARD-LOOKING STATEMENTS**

This Form C/A and any documents incorporated by reference herein contain forward-looking statements and are subject to risks and uncertainties. All statements other than statements of historical fact or relating to present facts or current conditions included in this Form C/A are forward-looking statements. Forward-looking statements give our current reasonable expectations and projections regarding our financial condition, results of operations, plans, objectives, future performance and business. You can identify forward-looking statements by the fact that they do not relate strictly to historical or current facts. These statements may include words such as “anticipate,” “estimate,” “expect,” “project,” “plan,” “intend,” “believe,” “may,” “should,” “can have,” “likely” and other words and terms of similar meaning in connection with any discussion of the timing or nature of future operating or financial performance or other events.

The forward-looking statements contained in this Form C/A and any documents incorporated by reference herein are based on reasonable assumptions we have made in light of our industry experience, perceptions of historical trends, current conditions, expected future developments and other factors we believe are appropriate under the circumstances. As you read and consider this Form C/A, you should understand that these statements are not guarantees of performance or results. Although we believe that these forward-looking statements are based on reasonable assumptions, you should be aware that many factors could affect our actual operating and financial performance and cause our performance to differ materially from the performance anticipated in the forward-looking statements. Should one or more of these risks or uncertainties materialize or should any of these assumptions prove incorrect or change, our actual operating and financial performance may vary in material respects from the performance projected in these forward-looking statements.

Investors are cautioned not to place undue reliance on these forward-looking statements. Any forward-looking statements made in this Form C/A or any documents incorporated by reference herein is accurate only as of the date of those respective documents. Except as required by law, we undertake no obligation to publicly update any forward-looking statements for any reason after the date of this Form C/A or to conform these statements to actual results or to changes in our expectations.

## SUMMARY

*The following summary highlights information contained elsewhere or incorporated by reference in this Form C/A. This summary may not contain all of the information that may be important to you. You should read this entire Form C/A carefully, including the matters discussed under the section titled "Risk Factors."*

### The Company

Quick Loadz Container System, LLC is a manufacturer of truck beds and trailers for sea shipping containers. The Company was formed in Ohio as a limited liability company on April 5, 2013.

The Company is located at 5850 Industrial Drive, Athens, OH 45701, United States.

The Company's website is <https://quickloadz.com>.

The Company is headquartered and qualified to conduct business in Ohio. The Company also sells its products through the Internet and throughout the United States and internationally, particularly in Canada.

A description of our products, services and business plan can be found on the Company's profile page on the Intermediary's website under <https://republic.com/quick-loadz> (the "Deal Page") and the version published as of the date of this Form C/A is attached as Exhibit B. The Deal Page can be used by prospective Investors to ask the Company questions and for the Company to post immaterial updates to this Form C/A as well as make general announcements. You should view Exhibit B as well as the Deal Page at the time you consider making an investment commitment.

### The Offering

<b>Minimum Amount of the Securities Offered</b>	25,000
<b>Total Amount of the Securities Outstanding after Offering (if Target Offering Amount met)</b>	25,000*
<b>Maximum Amount of the Securities Offered</b>	1,070,000
<b>Total Amount of the Securities Outstanding after Offering (if Maximum Offering Amount met)</b>	1,070,000*
<b>Price Per Security</b>	\$1.00
<b>Minimum Individual Purchase Amount</b>	\$150 <sup>+</sup>
<b>Maximum Individual Purchase Amount</b>	\$107,000
<b>Offering Deadline</b>	April 18, 2022
<b>Use of Proceeds</b>	See the description of the use of proceeds on page 18 hereof.
<b>Voting Rights</b>	See the description of the voting rights on page 29.

\*The total number of the Securities outstanding after the Offering is subject to increase in an amount equal to the Intermediary's fee of two percent (2%) of the Securities issued in this Offering.

+ The Company reserves the right to amend the Minimum Individual Purchase Amount and Maximum Individual Purchase Amount, in its sole discretion. In particular, the Company may elect to participate in one of the Intermediary's special investment programs and may offer alternative Minimum Individual Purchase Amounts and Maximum Individual Purchase Amounts to Investors participating in such programs without notice.



## **RISK FACTORS**

*Investing in the Securities involves a high degree of risk and may result in the loss of your entire investment. Before making an investment decision with respect to the Securities, we urge you to carefully consider the risks described in this section and other factors set forth in this Form C/A. In addition to the risks specified below, the Company is subject to same risks that all companies in its business, and all companies in the economy, are exposed to. These include risks relating to economic downturns, political and economic events and technological developments (such as hacking and the ability to prevent hacking). Additionally, early-stage companies are inherently riskier than more developed companies. Prospective Investors should consult with their legal, tax and financial advisors prior to making an investment in the Securities. The Securities should only be purchased by persons who can afford to lose all of their investment.*

### **Risks Related to the Company's Business and Industry**

***We have a limited operating history upon which you can evaluate our performance, and accordingly, our prospects must be considered in light of the risks that any new company encounters.***

The Company is still in an early phase and we are just beginning to implement our business plan. There can be no assurance that we will ever operate profitably. The likelihood of our success should be considered in light of the problems, expenses, difficulties, complications and delays usually encountered by early-stage companies. The Company may not be successful in attaining the objectives necessary for it to overcome these risks and uncertainties.

***Global crises, such as COVID-19, can have a significant effect on our business operations and revenue projections.***

The Company's revenue growth was adversely affected in 2020 related to the COVID-19 crisis. Global manufacturing and shipping were impacted as a result of the crisis. Conditions have eased in 2021. If another significant outbreak of COVID-19 or another contagious disease were to occur, we may lose a significant portion of our revenue.

In addition, a significant outbreak of contagious diseases in the human population could result in a widespread health crisis that could adversely affect the economies and financial markets of many countries, including the United States where we principally operate, resulting in an economic downturn that could reduce the demand for our products and services and impair our business prospects, including as a result of being unable to raise additional capital on acceptable terms to us, if at all.

***The amount of capital the Company is attempting to raise in this Offering may not be enough to sustain the Company's current business plan.***

In order to achieve the Company's near and long-term goals, the Company may need to procure funds in addition to the amount raised in the Offering. There is no guarantee the Company will be able to raise such funds on acceptable terms or at all. If we are not able to raise sufficient capital in the future, we may not be able to execute our business plan, our continued operations will be in jeopardy and we may be forced to cease operations and sell or otherwise transfer all or substantially all of our remaining assets, which could cause an Investor to lose all or a portion of their investment.

***We may face potential difficulties in obtaining capital.***

We may have difficulty raising needed capital in the future as a result of, among other factors, our lack of revenues from sales, as well as the inherent business risks associated with our Company and present and future market conditions. Our business currently has limited sales and future sources of revenue may not be sufficient to meet our future capital requirements. We will require additional funds to execute our business strategy and conduct our operations. If adequate funds are unavailable, we may be required to delay, reduce the scope of or eliminate one or more of our research, development or commercialization programs, product launches or marketing efforts, any of which may materially harm our business, financial condition and results of operations.

***We may implement new lines of business or offer new products and services within existing lines of business.***

As an early-stage company, we may implement new lines of business at any time. There are substantial risks and uncertainties associated with these efforts, particularly in instances where the markets are not fully developed. In developing and marketing new lines of business and/or new products and services, we may invest significant time and resources. Initial timetables for the introduction and development of new lines of business and/or new products or services may not be achieved, and price and profitability targets may not prove feasible. We may not be successful in introducing new products and services in response to industry trends or developments in technology, or those new products may not achieve market acceptance. As a result, we could lose business, be forced to price products and services on less advantageous terms to retain or attract clients or be subject to cost increases. As a result, our business, financial condition or results of operations may be adversely affected.

***We rely on other companies to provide components and services for our products.***

We depend on third party vendors to meet our contractual obligations to our customers and conduct our operations. Our ability to meet our obligations to our customers may be adversely affected if vendors do not provide the agreed-upon products or services in compliance with customer requirements and in a timely and cost-effective manner. Likewise, the quality of our products or services may be adversely impacted if companies to whom we delegate certain products or services do not perform to our, and our customers', expectations. Our vendors may also be unable to quickly recover from natural disasters and other events beyond their control and may be subject to additional risks such as financial problems that limit their ability to conduct their operations. The risk of these adverse effects may be greater in circumstances where we rely on only one or two vendors for a particular service.

***We rely on various intellectual property rights, including trademarks, in order to operate our business.***

The Company relies on certain intellectual property rights to operate its business. The Company's intellectual property rights may not be sufficiently broad or otherwise may not provide us a significant competitive advantage. In addition, the steps that we have taken to maintain and protect our intellectual property may not prevent it from being challenged, invalidated, circumvented or designed-around, particularly in countries where intellectual property rights are not highly developed or protected. In some circumstances, enforcement may not be available to us because an infringer has a dominant intellectual property position or for other business reasons, or countries may require compulsory licensing of our intellectual property. Our failure to obtain or maintain intellectual property rights that convey competitive advantage, adequately protect our intellectual property or detect or prevent circumvention or unauthorized use of such property, could adversely impact our competitive position and results of operations. We also rely on nondisclosure and noncompetition agreements with employees, consultants and other parties to protect, in part, trade secrets and other proprietary rights. There can be no assurance that these agreements will adequately protect our trade secrets and other proprietary rights and will not be breached, that we will have adequate remedies for any breach, that others will not independently develop substantially equivalent proprietary information or that third parties will not otherwise gain access to our trade secrets or other proprietary rights. As we expand our business, protecting our intellectual property will become increasingly important. The protective steps we have taken may be inadequate to deter our competitors from using our proprietary information. In order to protect or enforce our intellectual property rights, we may be required to initiate litigation against third parties, such as infringement lawsuits. Also, these third parties may assert claims against us with or without provocation. These lawsuits could be expensive, take significant time and could divert management's attention from other business concerns. We cannot assure you that we will prevail in any of these potential suits or that the damages or other remedies awarded, if any, would be commercially valuable.

***The Company's success depends on the experience and skill of its executive officers and key employees.***

We are dependent on our executive officers and key employees. The loss of any or all of our executive officers and key employees could harm the Company's business, financial condition, cash flow and results of operations.

***In order for the Company to compete and grow, it must attract, recruit, retain and develop the necessary personnel who have the needed experience.***

Recruiting and retaining highly qualified personnel is critical to our success. These demands may require us to hire additional personnel and will require our existing management and other personnel to develop additional expertise. We face intense competition for personnel, making recruitment time-consuming and expensive. The failure to attract and retain personnel or to develop such expertise could delay or halt the development and commercialization of our

product candidates. If we experience difficulties in hiring and retaining personnel in key positions, we could suffer from delays in product development, loss of customers and sales and diversion of management resources, which could adversely affect operating results. Our consultants and advisors may be employed by third parties and may have commitments under consulting or advisory contracts with third parties that may limit their availability to us, which could further delay or disrupt our product development and growth plans.

***We need to rapidly and successfully develop and introduce new products in a competitive, demanding and rapidly changing environment.***

To succeed in our intensely competitive industry, we must continually improve, refresh and expand our product and service offerings to include newer features, functionality or solutions, and keep pace with changes in the industry. Shortened product life cycles due to changing customer demands and competitive pressures may impact the pace at which we must introduce new products or implement new functions or solutions. In addition, bringing new products or solutions to the market entails a costly and lengthy process, and requires us to accurately anticipate changing customer needs and trends. We must continue to respond to changing market demands and trends or our business operations may be adversely affected.

***Damage to our reputation could negatively impact our business, financial condition and results of operations.***

Our reputation and the quality of our brand are critical to our business and success in existing markets and will be critical to our success as we enter new markets. Any incident that erodes consumer loyalty for our brand could significantly reduce its value and damage our business. We may be adversely affected by any negative publicity, regardless of its accuracy. Also, there has been a marked increase in the use of social media platforms and similar devices, including blogs, social media websites and other forms of internet-based communications that provide individuals with access to a broad audience of consumers and other interested persons. The availability of information on social media platforms is virtually immediate as is its impact. Information posted may be adverse to our interests or may be inaccurate, each of which may harm our performance, prospects or business. The harm may be immediate and may disseminate rapidly and broadly, without affording us an opportunity for redress or correction.

***We have not prepared any audited financial statements.***

The financial statements attached as Exhibit A to this Form C have been “reviewed” only and such financial statements have not been verified with outside evidence as to management’s amounts and disclosures. Additionally, tests on internal controls have not been conducted. Therefore, you will have no audited financial information regarding the Company’s capitalization or assets or liabilities on which to make your investment decision.

***Our business could be negatively impacted by cyber security threats, attacks and other disruptions.***

We may face advanced and persistent attacks on our information infrastructure where we manage and store various proprietary information and sensitive/confidential data relating to our operations. These attacks may include sophisticated malware (viruses, worms, and other malicious software programs) and phishing emails that attack our products or otherwise exploit any security vulnerabilities. These intrusions sometimes may be zero-day malware that are difficult to identify because they are not included in the signature set of commercially available antivirus scanning programs. Experienced computer programmers and hackers may be able to penetrate our network security and misappropriate or compromise our confidential information or that of our customers or other third-parties, create system disruptions, or cause shutdowns. Additionally, sophisticated software and applications that we produce or procure from third-parties may contain defects in design or manufacture, including “bugs” and other problems that could unexpectedly interfere with the operation of the information infrastructure. A disruption, infiltration or failure of our information infrastructure systems or any of our data centers as a result of software or hardware malfunctions, computer viruses, cyber-attacks, employee theft or misuse, power disruptions, natural disasters or accidents could cause breaches of data security, loss of critical data and performance delays, which in turn could adversely affect our business.

***Security breaches of confidential customer information, in connection with our electronic processing of credit and debit card transactions, or confidential employee information may adversely affect our business.***

Our business requires the collection, transmission and retention of personally identifiable information, in various information technology systems that we maintain and in those maintained by third parties with whom we contract to

provide services. The integrity and protection of that data is critical to us. The information, security and privacy requirements imposed by governmental regulation are increasingly demanding. Our systems may not be able to satisfy these changing requirements and customer and employee expectations, or may require significant additional investments or time in order to do so. A breach in the security of our information technology systems or those of our service providers could lead to an interruption in the operation of our systems, resulting in operational inefficiencies and a loss of profits. Additionally, a significant theft, loss or misappropriation of, or access to, customers' or other proprietary data or other breach of our information technology systems could result in fines, legal claims or proceedings.

***The use of individually identifiable data by our business, our business associates and third parties is regulated at the state, federal and international levels.***

The regulation of individual data is changing rapidly, and in unpredictable ways. A change in regulation could adversely affect our business, including causing our business model to no longer be viable. Costs associated with information security – such as investment in technology, the costs of compliance with consumer protection laws and costs resulting from consumer fraud – could cause our business and results of operations to suffer materially. Additionally, the success of our online operations depends upon the secure transmission of confidential information over public networks, including the use of cashless payments. The intentional or negligent actions of employees, business associates or third parties may undermine our security measures. As a result, unauthorized parties may obtain access to our data systems and misappropriate confidential data. There can be no assurance that advances in computer capabilities, new discoveries in the field of cryptography or other developments will prevent the compromise of our customer transaction processing capabilities and personal data. If any such compromise of our security or the security of information residing with our business associates or third parties were to occur, it could have a material adverse effect on our reputation, operating results and financial condition. Any compromise of our data security may materially increase the costs we incur to protect against such breaches and could subject us to additional legal risk.

***The Company is not subject to Sarbanes-Oxley regulations and may lack the financial controls and procedures of public companies.***

The Company may not have the internal control infrastructure that would meet the standards of a public company, including the requirements of the Sarbanes Oxley Act of 2002. As a privately-held (non-public) Company, the Company is currently not subject to the Sarbanes Oxley Act of 2002, and its financial and disclosure controls and procedures reflect its status as a development stage, non-public company. There can be no guarantee that there are no significant deficiencies or material weaknesses in the quality of the Company's financial and disclosure controls and procedures. If it were necessary to implement such financial and disclosure controls and procedures, the cost to the Company of such compliance could be substantial and could have a material adverse effect on the Company's results of operations.

***Changes in federal, state or local laws and government regulation could adversely impact our business.***

The Company is subject to legislation and regulation at the federal and local levels and, in some instances, at the state level. New laws and regulations may impose new and significant disclosure obligations and other operational, marketing and compliance-related obligations and requirements, which may lead to additional costs, risks of non-compliance, and diversion of our management's time and attention from strategic initiatives. Additionally, federal, state and local legislators or regulators may change current laws or regulations which could adversely impact our business. Further, court actions or regulatory proceedings could also change our rights and obligations under applicable federal, state and local laws, which cannot be predicted. Modifications to existing requirements or imposition of new requirements or limitations could have an adverse impact on our business.

***We operate in a highly regulated environment, and if we are found to be in violation of any of the federal, state, or local laws or regulations applicable to us, our business could suffer.***

We are also subject to a wide range of federal, state, and local laws and regulations. The violation of these or future requirements or laws and regulations could result in administrative, civil, or criminal sanctions against us, which may include fines, a cease and desist order against the subject operations or even revocation or suspension of our license to operate the subject business. As a result, we may incur capital and operating expenditures and other costs to comply with these requirements and laws and regulations.

***Changes in employment laws or regulation could harm our performance.***

Various federal and state labor laws govern our relationship with our employees and affect operating costs. These laws include minimum wage requirements, overtime pay, healthcare reform and the implementation of the Patient Protection and Affordable Care Act, unemployment tax rates, workers' compensation rates, citizenship requirements, union membership and sales taxes. A number of factors could adversely affect our operating results, including additional government-imposed increases in minimum wages, overtime pay, paid leaves of absence and mandated health benefits, mandated training for employees, increased tax reporting and tax payment requirements for employees who receive tips, a reduction in the number of states that allow tips to be credited toward minimum wage requirements, changing regulations from the National Labor Relations Board and increased employee litigation including claims relating to the Fair Labor Standards Act.

**Risks Related to the Offering**

***State and federal securities laws are complex, and the Company could potentially be found to have not complied with all relevant state and federal securities law in prior offerings of securities.***

The Company has conducted previous offerings of securities and may not have complied with all relevant state and federal securities laws. If a court or regulatory body with the required jurisdiction ever concluded that the Company may have violated state or federal securities laws, any such violation could result in the Company being required to offer rescission rights to investors in such offering. If such investors exercised their rescission rights, the Company would have to pay to such investors an amount of funds equal to the purchase price paid by such investors plus interest from the date of any such purchase. No assurances can be given the Company will, if it is required to offer such investors a rescission right, have sufficient funds to pay the prior investors the amounts required or that proceeds from this Offering would not be used to pay such amounts.

In addition, if the Company violated federal or state securities laws in connection with a prior offering and/or sale of its securities, federal or state regulators could bring an enforcement, regulatory and/or other legal action against the Company which, among other things, could result in the Company having to pay substantial fines and be prohibited from selling securities in the future.

***The Company could potentially be found to have not complied with securities law in connection with this Offering related to "Testing the Waters".***

Prior to filing its Form C, the Company engaged in "testing the waters" permitted under Regulation Crowdfunding (17 CFR 227.206), which allows issuers to communicate to determine whether there is interest in the Offering. All communication sent is deemed to be an offer of securities for purposes of the antifraud provisions of federal securities laws. Any Investor who expressed interest prior to the date of this Offering should read this Form C/A thoroughly and rely only on the information provided herein and not on any statement made prior to the Offering. The communication sent to Investors prior to the Offering is attached as Exhibit E.

***The U.S. Securities and Exchange Commission does not pass upon the merits of the Securities or the terms of the Offering, nor does it pass upon the accuracy or completeness of any Offering document or literature.***

You should not rely on the fact that our Form C/A is accessible through the U.S. Securities and Exchange Commission's EDGAR filing system as an approval, endorsement or guarantee of compliance as it relates to this Offering. The U.S. Securities and Exchange Commission has not reviewed this Form C/A, nor any document or literature related to this Offering.

***Neither the Offering nor the Securities have been registered under federal or state securities laws.***

No governmental agency has reviewed or passed upon this Offering or the Securities. Neither the Offering nor the Securities have been registered under federal or state securities laws. Investors will not receive any of the benefits available in registered offerings, which may include access to quarterly and annual financial statements that have been audited by an independent accounting firm. Investors must therefore assess the adequacy of disclosure and the fairness of the terms of this Offering based on the information provided in this Form C/A and the accompanying exhibits.

***The Company's management may have broad discretion in how the Company uses the net proceeds of the Offering.***

Unless the Company has agreed to a specific use of the proceeds from the Offering, the Company's management will have considerable discretion over the use of proceeds from the Offering. You may not have the opportunity, as part of your investment decision, to assess whether the proceeds are being used appropriately.

***The Company has the right to limit individual Investor commitment amounts based on the Company's determination of an Investor's sophistication.***

The Company may prevent any Investor from committing more than a certain amount in this Offering based on the Company's determination of the Investor's sophistication and ability to assume the risk of the investment. This means that your desired investment amount may be limited or lowered based solely on the Company's determination and not in line with relevant investment limits set forth by the Regulation CF rules. This also means that other Investors may receive larger allocations of the Offering based solely on the Company's determination.

***The Company has the right to extend the Offering Deadline.***

The Company may extend the Offering Deadline beyond what is currently stated herein. This means that your investment may continue to be held in escrow while the Company attempts to raise the Target Offering Amount even after the Offering Deadline stated herein is reached. While you have the right to cancel your investment in the event the Company extends the Offering Deadline, if you choose to reconfirm your investment, your investment will not be accruing interest during this time and will simply be held until such time as the new Offering Deadline is reached without the Company receiving the Target Offering Amount, at which time it will be returned to you without interest or deduction, or the Company receives the Target Offering Amount, at which time it will be released to the Company to be used as set forth herein. Upon or shortly after the release of such funds to the Company, the Securities will be issued and distributed to you.

***The Company may also end the Offering early.***

If the Target Offering Amount is met after 21 calendar days, but before the Offering Deadline, the Company can end the Offering by providing notice to Investors at least 5 business days prior to the end of the Offering. This means your failure to participate in the Offering in a timely manner, may prevent you from being able to invest in this Offering – it also means the Company may limit the amount of capital it can raise during the Offering by ending the Offering early.

***The Company has the right to conduct multiple closings during the Offering.***

If the Company meets certain terms and conditions, an intermediate close of the Offering can occur, which will allow the Company to draw down on seventy percent (70%) of the proceeds committed and captured in the Offering during the relevant period. The Company may choose to continue the Offering thereafter. Investors should be mindful that this means they can make multiple investment commitments in the Offering, which may be subject to different cancellation rights. For example, if an intermediate close occurs and later a material change occurs as the Offering continues, Investors whose investment commitments were previously closed upon will not have the right to re-confirm their investment as it will be deemed to have been completed prior to the material change.

## **Risks Related to the Securities**

***The Securities will not be freely tradable under the Securities Act until one year from the initial purchase date. Although the Securities may be tradable under federal securities law, state securities regulations may apply, and each Investor should consult with their attorney.***

You should be aware of the long-term nature of this investment. There is not now and likely will not ever be a public market for the Securities. Because the Securities have not been registered under the Securities Act or under the securities laws of any state or foreign jurisdiction, the Securities have transfer restrictions and cannot be resold in the United States except pursuant to Rule 501 of Regulation CF. It is not currently contemplated that registration under the Securities Act or other securities laws will be effected. Limitations on the transfer of the Securities may also

adversely affect the price that you might be able to obtain for the Securities in a private sale. Investors should be aware of the long-term nature of their investment in the Company. Each Investor in this Offering will be required to represent that they are purchasing the Securities for their own account, for investment purposes and not with a view to resale or distribution thereof.

***Investors will not have voting rights, even upon conversion of the Securities and will grant a third-party nominee broad power and authority to act on their behalf.***

In connection with investing in this Offering to purchase a Crowd SAFE (Simple Agreement for Future Equity) investors will designate Republic Investment Services LLC (f/k/a NextSeed Services, LLC) (“Nominee”) to act on their behalf as agent and proxy in all respects. The Nominee will be entitled, among other things, to exercise any voting rights (if any) conferred upon the holder of a Crowd SAFE or any securities acquired upon their conversion, to execute on behalf of an investor all transaction documents related to the transaction or other corporate event causing the conversion of the Crowd SAFE, and as part of the conversion process the Nominee has the authority to open an account in the name of a qualified custodian, of the Nominee’s sole discretion, to take custody of any securities acquired upon conversion of the Crowd SAFE. Thus, by participating in the Offering, investors will grant broad discretion to a third party (the Nominee and its agents) to take various actions on their behalf, and investors will essentially not be able to vote upon matters related to the governance and affairs of the Company nor take or effect actions that might otherwise be available to holders of the Crowd SAFE and any securities acquired upon their conversion. Investors should not participate in the Offering unless he, she or it is willing to waive or assign certain rights that might otherwise be afforded to a holder of the Crowd SAFE to the Nominee and grant broad authority to the Nominee to take certain actions on behalf of the investor, including changing title to the Security.

***Investors will not become equity holders until the Company decides to convert the Securities into “CF Shadow Securities” (the type of equity securities issuable upon conversion of the Securities) or until there is a change of control or sale of substantially all of the Company’s assets.***

Investors will not have an ownership claim to the Company or to any of its assets or revenues for an indefinite amount of time and depending on when and how the Securities are converted, the Investors may never become equity holders of the Company. Investors will not become equity holders of the Company unless the Company receives a future round of financing great enough to trigger a conversion and the Company elects to convert the Securities into CF Shadow Securities. The Company is under no obligation to convert the Securities into CF Shadow Securities. In certain instances, such as a sale of the Company or substantially all of its assets, an initial public offering or a dissolution or bankruptcy, the Investors may only have a right to receive cash, to the extent available, rather than equity in the Company. Further, the Investor may never become an equity holder, merely a beneficial owner of an equity interest, should the Company or the Nominee decide to move the Crowd SAFE or the securities issuable thereto into a custodial relationship.

***Investors will not have voting rights, even upon conversion of the Securities into CF Shadow Securities.***

Investors will not have the right to vote upon matters of the Company even if and when their Securities are converted into CF Shadow Securities (the occurrence of which cannot be guaranteed). Upon such conversion, the CF Shadow Securities will have no voting rights and, in circumstances where a statutory right to vote is provided by state law, the CF Shadow Security holders or the party holding the CF Shadow Securities on behalf of the Investors are required to enter into a proxy agreement with its designee to vote their CF Shadow Securities with the majority of the holder(s) of the securities issued in the round of equity financing that triggered the conversion right. For example, if the Securities are converted in connection with an offering of Series B Preferred Securities, Investors would directly or beneficially receive CF Shadow Securities in the form of interests of Series B-CF Shadow Preferred Securities and such interests would be required to be subject to a proxy that allows a designee to vote their shares of Series B-CF Shadow Preferred Securities consistent with the majority of the Series B Preferred Securities holders. Thus, Investors will essentially never be able to vote upon any matters of the Company unless otherwise provided for by the Company.

***Investors will not be entitled to any inspection or information rights other than those required by law.***

Investors will not have the right to inspect the books and records of the Company or to receive financial or other information from the Company, other than as required by law. Other security holders of the Company may have such rights. Regulation CF requires only the provision of an annual report on Form C and no additional information. Additionally, there are numerous methods by which the Company can terminate annual report obligations, resulting in no information rights, contractual, statutory or otherwise, owed to Investors. This lack of information could put Investors at a disadvantage in general and with respect to other security holders, including certain security holders who have rights to periodic financial statements and updates from the Company such as quarterly unaudited financials, annual projections and budgets, and monthly progress reports, among other things.

***Investors will be unable to declare the Security in “default” and demand repayment.***

Unlike convertible notes and some other securities, the Securities do not have any “default” provisions upon which Investors will be able to demand repayment of their investment. The Company has ultimate discretion as to whether or not to convert the Securities upon a future equity financing and Investors have no right to demand such conversion. Only in limited circumstances, such as a liquidity event, may Investors demand payment and even then, such payments will be limited to the amount of cash available to the Company.

***The Company may never elect to convert the Securities or undergo a liquidity event and Investors may have to hold the Securities indefinitely.***

The Company may never conduct a future equity financing or elect to convert the Securities if such future equity financing does occur. In addition, the Company may never undergo a liquidity event such as a sale of the Company or an initial public offering. If neither the conversion of the Securities nor a liquidity event occurs, Investors could be left holding the Securities in perpetuity. The Securities have numerous transfer restrictions and will likely be highly illiquid, with no secondary market on which to sell them. The Securities are not equity interests, have no ownership rights, have no rights to the Company’s assets or profits and have no voting rights or ability to direct the Company or its actions.

***Equity securities acquired upon conversion of the Securities may be significantly diluted as a consequence of subsequent equity financings.***

The Company’s equity securities will be subject to dilution. The Company intends to issue additional equity to employees and third-party financing sources in amounts that are uncertain at this time, and as a consequence holders of equity securities resulting from the conversion of the Securities will be subject to dilution in an unpredictable amount. Such dilution may reduce the Investor’s control and economic interests in the Company.

The amount of additional financing needed by the Company will depend upon several contingencies not foreseen at the time of this Offering. Generally, additional financing (whether in the form of loans or the issuance of other securities) will be intended to provide the Company with enough capital to reach the next major corporate milestone. If the funds received in any additional financing are not sufficient to meet the Company’s needs, the Company may have to raise additional capital at a price unfavorable to their existing investors, including the holders of the Securities. The availability of capital is at least partially a function of capital market conditions that are beyond the control of the Company. There can be no assurance that the Company will be able to accurately predict the future capital requirements necessary for success or that additional funds will be available from any source. Failure to obtain financing on favorable terms could dilute or otherwise severely impair the value of the Securities.

***Equity securities issued upon conversion of the Securities may be substantially different from other equity securities offered or issued by the Company at the time of conversion.***

In the event the Company decides to exercise the conversion right, the Company will convert the Securities into equity securities that are materially different from the equity securities being issued to new investors at the time of conversion in many ways, including, but not limited to, liquidation preferences, dividend rights, or anti-dilution protection. Additionally, any equity securities issued at the First Equity Financing Price (as defined in the Crowd SAFE agreement) shall have only such preferences, rights, and protections in proportion to the First Equity Financing Price and not in proportion to the price per unit paid by new investors receiving the equity securities. Upon conversion of



the Securities, the Company may not provide the holders of such Securities with the same rights, preferences, protections, and other benefits or privileges provided to other investors of the Company.

The foregoing paragraph is only a summary of a portion of the conversion feature of the Securities; it is not intended to be complete, and is qualified in its entirety by reference to the full text of the Crowd SAFE agreement, which is attached as Exhibit C.

***There is no present market for the Securities and we have arbitrarily set the price.***

The Offering price was not established in a competitive market. We have arbitrarily set the price of the Securities with reference to the general status of the securities market and other relevant factors. The Offering price for the Securities should not be considered an indication of the actual value of the Securities and is not based on our asset value, net worth, revenues or other established criteria of value. We cannot guarantee that the Securities can be resold at the Offering price or at any other price.

***In the event of the dissolution or bankruptcy of the Company, Investors will not be treated as debt holders and therefore are unlikely to recover any proceeds.***

In the event of the dissolution or bankruptcy of the Company, the holders of the Securities that have not been converted will be entitled to distributions as described in the Securities. This means that such holders will only receive distributions once all of the creditors and more senior security holders, including any holders of preferred securities, have been paid in full. Neither holders of the Securities nor holders of CF Shadow Securities can be guaranteed any proceeds in the event of the dissolution or bankruptcy of the Company.

***While the Securities provide mechanisms whereby holders of the Securities would be entitled to a return of their purchase amount upon the occurrence of certain events, if the Company does not have sufficient cash on hand, this obligation may not be fulfilled.***

Upon the occurrence of certain events, as provided in the Securities, holders of the Securities may be entitled to a return of the principal amount invested. Despite the contractual provisions in the Securities, this right cannot be guaranteed if the Company does not have sufficient liquid assets on hand. Therefore, potential Investors should not assume a guaranteed return of their investment amount.

***There is no guarantee of a return on an Investor's investment.***

There is no assurance that an Investor will realize a return on their investment or that they will not lose their entire investment. For this reason, each Investor should read this Form C/A and all exhibits carefully and should consult with their attorney and business advisor prior to making any investment decision.

**IN ADDITION TO THE RISKS LISTED ABOVE, RISKS AND UNCERTAINTIES NOT PRESENTLY KNOWN, OR WHICH WE CONSIDER IMMATERIAL AS OF THE DATE OF THIS FORM C/A, MAY ALSO HAVE AN ADVERSE EFFECT ON OUR BUSINESS AND RESULT IN THE TOTAL LOSS OF YOUR INVESTMENT.**

## BUSINESS

### Description of the Business

QuickLoadz, also known as QuickLoadz Intermodal Robotics, builds truck beds and trailers that load and unload sea shipping containers. Our products allow an operator to move up to sixty thousand pounds in sea shipping containers using only their smart devices in three minutes without leaving their seat in the cab of the truck. This ability to easily move loaded sea shipping containers creates all new possibilities for streamlining world freight and logistics. Ninety percent of all freight travels in sea shipping containers and QuickLoadz creates the ability to move those one hundred and sixty five million containers in an easy way never before possible.

### Business Plan

The Company plans to significantly expand its business by increasing sales and marketing streamlining production and new hires in HR. The Company aims to achieve profitability by mid-2022. The capital we raise here will empower us to expand our product development, increase sales and marketing efforts and grow out our infrastructure as we continue to aggressively grow and expand our business.

### The Company's Products and/or Services

Product / Service	Description	Current Market
16k Super20	Multiuse light weight 16,000 pound GVWR trailer. Coupled with a less than 10,000 pound GVWR pickup truck this is a non-CDL way to move equipment and lightly loaded 20 foot sea shipping containers. Design features: 4 built in Wi-Fi cameras for high visibility on a smart phone. Ability to unload itself of pallets. 38 HP EFI Kohler engine or all electric powerpack. Smartphone control allows loading or unloading of sea shipping containers without driver leaving truck cab in 3 minutes. Available in gooseneck or bumper hitch. With gooseneck swappable center hitch allows for towing with a pickup truck or semi-truck.	B2B direct sales, aimed at general contractors, mobile storage, container modifiers (tiny houses, popup bars and restaurants)
24k Super20	Multiuse middle weight 24,000 pound GVWR trailer. This medium weight trailer will move heavier equipment small bulldozers, manlifts and loaded 20-foot sea shipping containers. Design features: 4 built in Wi-Fi cameras for high visibility on a smart phone. Ability to unload itself of pallets. 38 HP EFI Kohler engine or all electric powerpack. Smartphone control allows loading or unloading of sea shipping containers without driver leaving truck cab in 3 minutes. Available in gooseneck or bumper hitch. With gooseneck swappable center hitch allows for towing with a pickup truck or semi-truck.	B2B direct sales, B2B direct sales, aimed at general contractors, mobile storage, container modifiers (tiny houses, popup bars and restaurants), moving companies, utility companies.

40k Super20	Multiuse heavy weight 40,000 pound GVWR trailer. This heavy weight trailer will move heavy equipment, mid-sized bulldozers, manlifts and loaded 20-foot sea shipping containers. Design features: 4 built in Wi-Fi cameras for high visibility on a smart phone. Ability to unload itself of pallets. 38 HP EFI Kohler engine or all electric powerpack. Smartphone control allows loading or unloading of sea shipping containers without driver leaving truck cab in 3 minutes. Available only with a 5th wheel hitch for towing by a semi-truck.	B2B direct sales, aimed at general contractors, container modifiers (containerized generator sets, water purification systems, other heavy containerized equipment), freight and trucking companies, large end users of 20' sea shipping containers.
20k Superbed	Multiuse bed for single and double axle trucks. These beds allow a user to load or unload a sea shipping container in 3 minutes without leaving their seat in the truck cab. These beds are designed to be multifunctional as tow trucks, equipment movers and dump trucks. Design features: 4 built in Wi-Fi cameras for high visibility on a smart phone. Ability to unload itself of pallets. Smartphone control allows loading or unloading of sea shipping containers without driver leaving truck cab in 3 minutes. 45 degree tilt angle allows the truck to also act as a dump truck.	B2B direct sales, aimed at general contractors, mobile storage, container modifiers (tiny houses, popup bars and restaurants), emergency services.
40k Superbed	Multiuse bed for double and triple axle trucks. These beds allow a user to load or unload a sea shipping container in 3 minutes without leaving their seat in the truck cab. These beds are designed to be multifunctional as tow trucks, equipment movers and dump trucks. Design features: 4 built in Wi-Fi cameras for high visibility on a smart phone. Ability to unload itself of pallets. Smartphone control allows loading or unloading of sea shipping containers without driver leaving truck cab in 3 minutes. 45 degree tilt angle allows the truck to also act as a dump truck.	B2B direct sales, aimed at general contractors, mobile storage, container modifiers (tiny houses, popup bars and restaurants), emergency services.
20k Super Short 40	Single axle light weight trailer designed to be pulled by a semi-truck. This trailer is capable of moving other light (less than 12,000 pound) loads but is primarily designed as a short trailer for moving empty sea shipping containers. Design features: 4 built in	B2B direct sales, aimed at mobile storage

	<p>Wi-Fi cameras for high visibility on a smart phone. Ability to unload itself of pallets. 38 HP EFI Kohler engine or all electric powerpack. Smartphone control allows loading or unloading of sea shipping containers without driver leaving truck cab in 3 minutes, sliding axles with driver smart phone control allow the driver to maneuver in tight spots by sliding the axles forward without leaving their seat in the truck cab. Design features: 4 built in Wi-Fi cameras for high visibility on a smart phone. Ability to unload itself of pallets. 38 HP EFI Kohler engine or all electric powerpack. Smartphone control allows loading or unloading of sea shipping containers without driver leaving truck cab in 3 minutes, sliding axles with driver smart phone control allow the driver to maneuver in tight spots by sliding the axles forward without leaving their seat in the truck cab. The trailer can also move 2 20' containers, 4 10' containers or any variety.</p>	
40k Super Short 40	<p>Double axle medium weight trailer designed to be pulled by a semi-truck and move loaded 40' containers. This trailer is capable of moving medium loads but is primarily designed as a short trailer for moving loaded sea shipping containers. Design features: 4 built in Wi-Fi cameras for high visibility on a smart phone. Ability to unload itself of pallets. 38 HP EFI Kohler engine or all electric powerpack. Smartphone control allows loading or unloading of sea shipping containers without driver leaving truck cab in 3 minutes. Sliding axles with driver smart phone controls allow the driver to maneuver in tight spots by sliding the axles forward without leaving their seat in the truck cab. The trailer can also move 2 20' containers, 4 10' containers or any variety.</p>	<p>B2B direct sales, aimed at mobile storage, container modifiers (containerized generator sets, water purification systems, other heavy containerized equipment), freight and trucking companies, large end users of 40' sea shipping containers.</p>
26k Super 40	<p>Versatile light weight 26,000 pound GVWR trailer. This lightweight trailer will move heavier equipment small bulldozers, manlifts and lightly loaded 40-foot sea shipping containers. Design features: 4 built in Wi-Fi cameras for high visibility on a smart phone. Ability to unload itself of pallets. 38 HP EFI Kohler engine or all electric powerpack. Smartphone</p>	<p>B2B direct sales, aimed at mobile storage, general contractors and hot shot truckers.</p>

	<p>control allows loading or unloading of sea shipping containers without driver leaving truck cab in 3 minutes. Available in gooseneck or bumper hitch. With gooseneck swappable center hitch allows for towing with a pickup truck or semi-truck. sliding axles with driver smart phone control allow the driver to maneuver in tight spots by sliding the axles forward without leaving their seat in the truck cab. The trailer can also move 2 20' containers, 4 10' containers or any variety.</p>	
40k Super 40	<p>Versatile middle weight 40,000 pound GVWR trailer. This middle weight trailer will move heavier equipment small bulldozers, manlifts and lightly loaded 40-foot sea shipping containers. Design features: 4 built in Wi-Fi cameras for high visibility on a smart phone. Ability to unload itself of pallets. 38 HP EFI Kohler engine or all electric powerpack. Smartphone control allows loading or unloading of sea shipping containers without driver leaving truck cab in 3 minutes. Available in gooseneck or bumper hitch. With gooseneck swappable center hitch allows for towing with a pickup truck or semi-truck. sliding axles with driver smart phone control allow the driver to maneuver in tight spots by sliding the axles forward without leaving their seat in the truck cab. The trailer can also move 2 20' containers, 4 10' containers or any variety.</p>	<p>B2B direct sales, aimed at general contractors, container modifiers (containerized generator sets, water purification systems, other heavy containerized equipment), freight and trucking companies, large end users of 40' sea shipping containers.</p>
60k Super 40	<p>Heavy weight trailer product, 60,000 pound GVWR trailer. This heavy weight trailer will move heavy equipment, standard flatbed loads and heavily loaded 40 foot sea shipping containers. Design features: 4 built in Wi-Fi cameras for high visibility on a smart phone. Ability to unload itself of pallets. 38 HP EFI Kohler engine or all electric powerpack. Smartphone control allows loading or unloading of sea shipping containers without driver leaving truck cab in 3 minutes. Sliding axles with driver smart phone control allow the driver to maneuver in tight spots by sliding the axles forward without leaving their seat in the truck cab. The trailer can also</p>	<p>B2B direct sales, aimed at revolutionizing the freight and logistics markets this unit will move the heavy 40' foot sea shipping containers that are the backbone of world trade. This unit will automate the 90% of world freight that uses 40' sea shipping containers everywhere from seaports, distribution centers to farmers.</p>

	move 2 20' containers, 4 10' containers or any variety.	
--	---	--

**Competition**

Although our product is unique, the overall markets in which our products are sold are highly competitive. Our products compete against different products of many large and small companies, including well-known global competitors.

In our particular space, side lift crane trailers are the primary competitors in the market of moving loaded sea shipping containers. Side lift cranes work by having a large folding crane at either end of a trailer. The trailer pulls up next to the container, cranes are unfolded, the operator attaches chains to the container and then operating both cranes at once lifts the container four feet into the air and sets it on the trailer. The container is then disconnected from the 2 cranes, chains stowed, cranes folded back into travel position. The side lift crane market is dominated by HammarLift, a Swedish company. Side lift crane trailers are twice as heavy (reduced payload), twice as expensive (four times as expensive in operating costs), eight times slower, inherently dangerous, and require a skilled, trained operator and cannot by their nature be automated. The operator must always rig the container to be lifted, operate the cranes and make certain of the stability of the trailer while lifting the container. Most importantly, they cannot be used with freight systems such as loading docks (there is a crane in the way of accessing the contents of the sea shipping container) and therefore side lift cranes simply do not work well in freight and logistics and are relegated to a small, niche \$100,000,000 market. In moving empty containers there is competition from a large variety of trailer manufacturers that make traditional (tow style) trucks and trailers. This is a limited market that is dominated by Landoll Corporation's version of the container trailer. These are essentially tow trailers and are not well suited for moving loaded sea shipping containers and by their labor-intensive nature cannot be automated. Even though a QuickLoadz trailer is often 10% more expensive than similar Landoll trailers and there is heavy competition in this market, QuickLoadz currently sells 20% into this market. A large mobile storage company reported a 40% increase in productivity when using a QuickLoadz trailer over a traditional tow style trailer. The increase in productivity can produce a one month return on investment on the difference in price between a QuickLoadz trailer and a traditional tow trailer. In addition, it is possible for a customer to charge ten times as much to move a loaded sea shipping container instead of an empty container which only leads to a much more rapid return on investment. In comparison to these specific competitors, QuickLoadz primary advantages are speed, automation and driver safety. There has never been a reported injury with a QuickLoadz trailer, and with a QuickLoadz trailer, almost any driver can load or unload sea shipping container with just minutes of training.

**Customer Base**

We sell B2B in the mobile storage, general contractor, freight, emergency services, military, utility and moving spaces.

**Supply Chain**

Although the Company is dependent upon certain third party vendors, the Company has access to alternate service providers in the event its current third-party vendors are unable to provide services or any issues arise with its current vendors where a change is required to be made. The Company does not believe the loss of a current third-party vendor or service provider would cause a major disruption to its business, although it could cause short-term limitations or disruptions.

## Intellectual Property

### Patents

Application or Registration #	Title	Description	File Date	Grant Date	Country
8,870,517	"Container Loading and Unloading System"	Patent	December 8, 2011	October 28, 2014	USA
9,969,314	"Container Loading and Unloading System"	Patent	August 28, 2014	May 15, 2018	USA
2788222	"Container Loading and Unloading System"	Patent	September 22, 2014	February 1, 2017	European Union
2012348242	"Container Loading and Unloading System"	Patent	November 20, 2012	February 16, 2017	Australia
ZL201280067919.1	"Container Loading and Unloading System"	Patent	July 23, 2014	March 29, 2017	China
6223996	"Container Loading and Unloading System"	Patent	June 5, 2014	October 13, 2017	Japan
2858542	"Container Loading and Unloading System"	Patent	November 20, 2012	August 13, 2019	Canada
10-2031329	"Container Loading and Unloading System"	Patent	July 8, 2014	October 4, 2019	Korea
BR112014013823-0	"Container Loading and Unloading System"	Patent	November 20, 2012	Application Pending	Brazil

5282/DELNP/2014	"Container Loading and Unloading System"	Patent	June 26, 2014	Application Pending	India
-----------------	--	--------	---------------	---------------------	-------

### ***Trademarks***

<b>Application or Registration #</b>	<b>Title</b>	<b>Description</b>	<b>File Date</b>	<b>Grant Date</b>	<b>Country</b>
5,570,770	QuickLoadz	Standard Character Mark	May 4, 2018	September 25, 2018	USA
90843108	QuickLoadz Intermodal Robotics	Standard Character Mark	July 22, 2021	Pending	USA

All other intellectual property is in the form of trade secrets, business methods and know-how and is protected through intellectual assignment and confidentiality agreements with Company employees, advisors and consultants.

### ***Domain Names***

The Company owns the following active domain names: (i) quickloadz.com, (ii) quickloadz.co, (iii) quickloadz.org, (iv) quickloadz.net, (v) quickloadz.info and (vi) the-box-store.com.

### **Governmental/Regulatory Approval and Compliance**

The Company is subject to and affected by the laws and regulations of U.S. federal, state and local governmental authorities. These laws and regulations are subject to change.

### **Litigation**

The Company is not subject to any current litigation or threatened litigation.



## USE OF PROCEEDS

The following table illustrates how we intend to use the net proceeds received from this Offering. The values below are not inclusive of payments to financial and legal service providers and escrow related fees, all of which were incurred in the preparation of this Offering and are due in advance of the closing of the Offering.

Use of Proceeds	% of Proceeds if Target Offering Amount Raised	Amount if Target Offering Amount Raised	% of Proceeds if Maximum Offering Amount Raised	Amount if Maximum Offering Amount Raised
Intermediary Fees	6%	\$1,500	6%	\$64,200
Production(1)	30%	\$7,500	30%	\$321,000
Sales and Marketing (2)	35%	\$8,750	35%	\$374,500
Infrastructure (3)	29%	\$7,250	29%	\$310,300
<b>Total</b>	<b>100%</b>	<b>\$25,000</b>	<b>100%</b>	<b>\$1,070,000</b>

The Company has discretion to alter the use of proceeds set forth above to adhere to the Company's business plan and liquidity requirements. For example, economic conditions may alter the Company's general marketing or general working capital requirements.

Set forth below are detailed descriptions of how we intend to use the net proceeds of this Offering for any category in excess of ten percent (10%) in the table above.

(1) We will use these proceeds to streamline our production process and create additional inventory.

(2) Our sales and marketing efforts are handled by a small team. We will use the proceeds to hire additional sales members and engage in targeted marketing efforts.

(3) These proceeds will be used to build out the Company's infrastructure. Currently, our management handles a wide range of administrative and operational functions. We expect to hire additional employees to assist with these functions.

## DIRECTORS, OFFICERS, MANAGERS AND KEY PERSONS

The directors, officers, managers and key persons of the Company are listed below along with all positions and offices held at the Company and their principal occupation and employment responsibilities for the past three (3) years.

Name	Positions and Offices Held at the Company	Principal Occupation and Employment Responsibilities for the Last Three (3) Years	Education
Sean Jones	CEO, Co-Founder and Managing Member	CEO and Co-Founder of Quick Loadz, 2013 – Present  Responsible for sales, operations, and general CEO responsibilities  Owner Rockside Rentals, 1984- Present	Ohio University, B.S. with Honors. Engineering, 1985
Bridget Lair	Chief Financial Officer and Co-Founder	Chief Financial Officer and Co-Founder of Quick Loadz, 2013 – Present  Responsible for Financial Operations of Company  Senior Research Associate, Voinovich School of Leadership and Public Affairs, Ohio University	Ohio University, M.A. Geography, 2002; M.A., International Affairs, 2000

### Biographical Information

Sean Jones: Sean is the CEO, Co-Founder and Managing Member of the Company. He is an engineer and serial entrepreneur with several successful exits. After selling a mobile storage company to a multinational company, Sean focused on building a safer, faster, easier way to move loaded ISO containers. After designing several prototypes, Sean patented QuickLoadz in the U.S., Europe, Australia, China, India, Canada and others. He has successfully commercialized the product across multiple market sectors and has captured repeat customers from multinational enterprise companies.

Bridget Lair: Bridget is the CFO and Co-Founder of the Company. She is trained as a research scientist in ecology and international affairs. Bridget is a published author on best practices in business incubation and her research on fire ecology, land use and land cover change is published in multiple peer reviewed journals and books. She has extensive experience in statistical analysis and data management. As CFO of the Company, Bridget works closely with Sean to set Company strategy and financial planning. Before joining the Company, Bridget was a Senior Research Analyst in Leadership and Public Affairs.

### Indemnification

Indemnification is authorized by the Company to managers, officers or controlling persons acting in their professional capacity pursuant to Ohio law. Indemnification includes expenses such as attorney’s fees and, in certain circumstances, judgments, fines and settlement amounts actually paid or incurred in connection with actual or threatened actions, suits or proceedings involving such person, except in certain circumstances where a person is adjudged to be guilty of gross negligence or willful misconduct, unless a court of competent jurisdiction determines that such indemnification is fair and reasonable under the circumstances.

### Employees

The Company currently has 20 employees.

## CAPITALIZATION, DEBT AND OWNERSHIP

### Capitalization

The Company's authorized equity interests consists of 100 common membership interests (the “**Common Membership Interests**”). At the closing of this Offering, assuming only the Target Offering Amount is sold, 100 Common Membership Units will be issued and outstanding.

### *Outstanding Equity Interests*

As of the date of this Form C/A, the Company’s outstanding equity interests consists of:

Type	Common Membership Interests
Amount Outstanding	100
Voting Rights	1 vote per each membership interest percentage or a fraction thereof
How this security may limit, dilute or qualify the Security issued pursuant to Regulation CF	The Company may issue additional shares of Common Membership Interests at a later date. The issuance of such additional shares of Common Membership Interests would be dilutive, and could adversely affect the value of the Securities issued pursuant to Regulation CF.
Percentage ownership of the Company by the holders of such security (assuming conversion prior to the Offering if convertible securities).	100%

## Outstanding Debt

As of the date of this Form C/A, the Company has the following debt outstanding:

<b>Type</b>	SBA Loan (7a)
<b>Amount Outstanding</b>	\$2,608,209
<b>Interest Rate and Amortization Schedule</b>	6% per annum. Installment payments, including principal and interest of \$25,292.56 paid through March 1, 2022.
<b>Description of Collateral</b>	All assets.
<b>Other Material Terms</b>	N/A
<b>Maturity Date</b>	January 25, 2034

<b>Type</b>	SBA EIDL Loan
<b>Amount Outstanding</b>	\$423,500
<b>Interest Rate and Amortization Schedule</b>	3.75% per annum. Installment payments, including principal and interest of \$2,103 monthly will begin twenty-four (24) months from the date of issuance of the promissory note. The balance of principal and interest will be payable thirty (30) years from the date of the promissory note.
<b>Description of Collateral</b>	All assets.
<b>Maturity Date</b>	April 21, 2050

<b>Type</b>	Vehicle Loan- Ohio University Credit Union
<b>Amount Outstanding</b>	\$12,473
<b>Interest Rate and Amortization Schedule</b>	5.49% per annum Installment payments, including principal and interest, of \$493 monthly.
<b>Description of Collateral</b>	Ford 150 Vehicle
<b>Maturity Date</b>	September 23, 2023

<b>Type</b>	Microkinetics Equipment Loan
<b>Amount Outstanding</b>	\$26,666
<b>Interest Rate and Amortization Schedule</b>	5.5% per annum Installment payments, including principal and interest of \$1,075.09 monthly.
<b>Description of Collateral</b>	Equipment
<b>Maturity Date</b>	April 21, 2024

<b>Type</b>	Messer Equipment Loan
<b>Amount Outstanding</b>	59,983.43
<b>Interest Rate and Amortization Schedule</b>	5.5% per annum Installment payments, including principal and interest of \$1,075.09 monthly.
<b>Description of Collateral</b>	Equipment
<b>Maturity Date</b>	April 21, 2024

<b>Type</b>	American Express Business Line of Credit
<b>Amount Outstanding</b>	\$172,367
<b>Interest Rate and Amortization Schedule</b>	1.8-2.6% (up to three months from date of use)
<b>Description of Collateral</b>	Unsecured
<b>Maturity Date</b>	April 4, 2022

### Ownership

The table below lists the beneficial owners of twenty percent (20%) or more of the Company's outstanding voting equity securities, calculated on the basis of voting power, are listed along with the amount they own.

<b>Name</b>	<b>Amount and Type or Class Held</b>	<b>Percentage Ownership (in terms of voting power)</b>
Sean Jones	Membership Interests	77.341%
Bridget M. Lair	Membership Interests	20%

## FINANCIAL INFORMATION

Please see the financial information listed on the cover page of this Form C/A and in the financial statements attached hereto as Exhibit A, in addition to the following information.

### Operations

Quick Loadz Container System, LLC (the “**Company**”) was incorporated on April 5, 2013 under the laws of the State of Ohio, and is headquartered in Athens Ohio.

### Cash and Cash Equivalents

The Company considers short-term, highly liquid investment with original maturities of three months or less at the time of purchase to be cash equivalents. Cash consists of funds held in the Company’s checking account.

As of January 31, 2022, the Company had an aggregate of \$550,000 in cash and cash equivalents, in addition to ongoing revenue of approximately \$170,000 per month, leaving the Company with approximately 12 months of recurring runway.

### Liquidity and Capital Resources

The proceeds from the Offering are essential to our operations. We plan to use the proceeds as set forth above under the section titled “*Use of Proceeds*”, which is an indispensable element of our business strategy.

### Capital Expenditures and Other Obligations

QuickLoadz intends to purchase capital equipment costing approximately \$469,000 to be installed at its assembly plant. It is intended that bank financing will be used for these capital expenditures and not any proceeds from the Offering.

### Valuation

The Company has ascribed no pre-Offering valuation to the Company; the securities are priced arbitrarily.

### Material Changes and Other Information

This non-material amendment is filed to note the change in Escrow Agent.

### *Trends and Uncertainties*

After reviewing the above discussion of the steps the Company intends to take, potential Investors should consider whether achievement of each step within the estimated time frame will be realistic in their judgment. Potential Investors should also assess the consequences to the Company of any delays in taking these steps and whether the Company will need additional financing to accomplish them.

Please see the financial statements attached as Exhibit A for subsequent events and applicable disclosures.

## Previous Offerings of Securities

We have made the following issuances of securities within the last three years:

Security Type	Principal Amount of Securities Sold	Amount of Securities Issued	Use of Proceeds	Issue Date	Exemption from Registration Used or Public Offering
Membership Interests	\$160,000	1.333%	General Working Capital	May 10, 2021	Section 4(a)(2)
Membership Interests Acquired Pursuant to Promissory Note Conversion*	\$0	1.325%	N/A	May 10, 2021	Section 4(a)(2)

\*Converted promissory note of \$159,061.60, entered into on June 30, 2017, into Membership Interests in the Company.

See the section titled “*Capitalization and Ownership*” for more information regarding the securities issued in our previous offerings of securities.

## TRANSACTIONS WITH RELATED PERSONS AND CONFLICTS OF INTEREST

From time to time the Company may engage in transactions with related persons. Related persons are defined as any director or officer of the Company; any person who is the beneficial owner of twenty percent (20%) or more of the Company’s outstanding voting equity securities, calculated on the basis of voting power; any promoter of the Company; any immediate family member of any of the foregoing persons or an entity controlled by any such person or persons. Additionally, the Company will disclose here any transaction since the beginning of the issuer's last fiscal year, or any currently proposed transaction, to which the issuer was or is to be a party and the amount involved exceeds five percent (5%) of the aggregate amount of capital raised by the issuer in reliance on section 4(a)(6), including the Target Offering Amount of this Offering, and the counter party is either (i) any director or officer of the issuer; (ii) any person who is, as of the most recent practicable date but no earlier than 120 days prior to the date the offering statement or report is filed, the beneficial owner of twenty percent (20%) or more of the issuer's outstanding voting equity securities, calculated on the basis of voting power; (iii) if the issuer was incorporated or organized within the past three years, any promoter of the issuer; or (iv) any member of the family of any of the foregoing persons, which includes a child, stepchild, grandchild, parent, stepparent, grandparent, spouse or spousal equivalent, sibling, mother-in-law, father-in-law, son-in-law, daughter-in-law, brother-in-law, or sister-in-law, and shall include adoptive relationships. The term *spousal equivalent* means a cohabitant occupying a relationship generally equivalent to that of a spouse.

The Company has conducted the following transactions with related persons: None.

## THE OFFERING AND THE SECURITIES

### The Offering

The Company is offering a minimum amount of \$25,000 (the “**Target Offering Amount**”) and up to a maximum amount of \$1,070,000 (the “**Maximum Offering Amount**”) of Crowd SAFE (Simple Agreement for Future Equity) (the “**Securities**”) on a best efforts basis as described in this Form C/A (this “**Offering**”). We must raise an amount equal to or greater than the Target Offering Amount by April 18, 2022 (the “**Offering Deadline**”). Unless we receive investment commitments, which are fully paid for and meet all other requirements set by this Offering, in an amount not less than the Target Offering Amount by the Offering Deadline, no Securities will be sold in this Offering, all investment commitments will be cancelled and all committed funds will be returned. Potential purchasers of the Securities are referred to herein as “**Investors**” or “**you**”.

In addition to the Offering, the Company intends to concurrently undertake to raise an additional \$3,000,000 pursuant to Rule 506(b) of Regulation D by offering to sell up to \$3,000,000 in SAFEs (Simple Agreement for Future Equity) to accredited investors outside of this Offering (the “**Concurrent Offering**”). No investors in this Offering, or potential investors who learned of the Company as a result of this Offering, will be permitted to invest in the Concurrent Offering. The terms of the SAFEs in the Concurrent Offering will be different than the terms of the Crowd SAFE in this Offering.

The price of the Securities was determined arbitrarily, does not necessarily bear any relationship to the Company’s asset value, net worth, revenues or other established criteria of value, and should not be considered indicative of the actual value of the Securities. The minimum amount that an Investor may invest in the Offering is \$150 and the maximum amount that an Investor may invest in the Offering is \$107,000, each of which is subject to adjustment in the Company’s sole discretion.

In order to purchase the Securities, you must make a commitment to purchase by completing the subscription process hosted by OpenDeal Portal LLC dba Republic (the “**Intermediary**”), including complying with the Intermediary’s know your customer (KYC) and anti-money laundering (AML) policies. **If an Investor makes an investment commitment under a name that is not their legal name, they may be unable to redeem their Security indefinitely, and neither the Intermediary nor the Company are required to correct any errors or omissions made by the Investor.**

Investor funds will be held in escrow with Prime Trust, LLC until the Target Offering Amount has been met or exceeded and one or more closings occur. Investors may cancel an investment commitment until up to 48 hours prior to the Offering Deadline, or such earlier time as the Company designates pursuant to Regulation CF, using the cancellation mechanism provided by the Intermediary. **Investors using a credit card to invest must represent and warrant to cancel any investment commitment(s) by submitting a request through the Intermediary at least 48 hours prior to the Offering Deadline, instead of attempting to claim fraud or claw back their committed funds.**

The Company will notify Investors when the Target Offering Amount has been reached through the Intermediary. If the Company reaches the Target Offering Amount prior to the Offering Deadline, it may close the Offering early *provided* (i) the expedited Offering Deadline must be twenty-one (21) days from the time the Offering was opened, (ii) the Intermediary must provide at least five (5) business days’ notice prior to the expedited Offering Deadline to the Investors and (iii) the Company continues to meet or exceed the Target Offering Amount on the date of the expedited Offering Deadline.

### Material Changes

If any material change occurs related to the Offering prior to the current Offering Deadline the Company will provide notice to Investors and receive reconfirmations from Investors who have already made commitments. If an Investor does not reconfirm their investment commitment after a material change is made to the terms of the Offering within five (5) business days of receiving notice, the Investor’s investment commitment will be cancelled and the committed funds will be returned without interest or deductions. If an Investor does not cancel an investment commitment before the Target Offering Amount is reached, the funds will be released to the Company upon the closing of the Offering and the Investor will receive the Securities in exchange for their investment.



## **Intermediate Closings**

In the event an amount equal to two (2) times the Target Offering Amount is committed and meets all required terms of the Offering prior to the Offering Deadline on such date or such later time the Company designates pursuant to Rule 304(b) of Regulation CF, the Company may conduct the first of multiple closings of the Offering early, *provided* (i) the new early closing date must be twenty-one (21) days from the time the Offering was opened and (ii) that all Investors will receive notice of such early closing date at least five (5) business days prior to such new offering deadline (absent a material change that would require an extension of the Offering and reconfirmation of all investment commitments). Investors who committed on the date such notice is provided or prior to the issuance of such notice will be able to cancel their investment commitment until 48 hours before such early closing date.

If the Company conducts an initial closing (the “**Initial Closing**”), the Company agrees to only withdraw seventy percent (70%) of the proceeds that are in escrow and will only conduct such Initial Closing if there are more than twenty-one (21) days remaining before the Offering Deadline as of the date of the Initial Closing. The Company may only conduct another close (a “**Subsequent Closing**”) before the Offering Deadline if the amount of investment commitments made as of the date of such Subsequent Closing exceeds two times the Target Offering Amount as of the date of the Initial Closing and there are more than twenty-one (21) days remaining before the Offering Deadline as of the date of such Subsequent Closing.

Any investment commitments received after an intermediate closing will be released to the Company upon a subsequent closing and the Investor will receive evidence of the Securities via electronic certificate/PDF in exchange for their investment commitment as soon as practicable thereafter.

The Company has agreed to return all funds to Investors in the event a Form C-W is ultimately filed in relation to this Offering, regardless of whether multiple closings are conducted.

Investment commitments are not binding on the Company until they are accepted by the Company, which reserves the right to reject, in whole or in part, in its sole and absolute discretion, any investment commitment. If the Company rejects all or a portion of any investment commitment, the applicable prospective Investor’s funds will be returned without interest or deduction.

**PRIME TRUST, LLC, THE ESCROW AGENT SERVICING THE OFFERING, HAS NOT INVESTIGATED THE DESIRABILITY OR ADVISABILITY OF AN INVESTMENT IN THIS OFFERING OR THE SECURITIES OFFERED HEREIN. THE ESCROW AGENT MAKES NO REPRESENTATIONS, WARRANTIES, ENDORSEMENTS, OR JUDGEMENT ON THE MERITS OF THE OFFERING OR THE SECURITIES OFFERED HEREIN. THE ESCROW AGENT’S CONNECTION TO THE OFFERING IS SOLELY FOR THE LIMITED PURPOSES OF ACTING AS A SERVICE PROVIDER.**

## **The Securities**

We request that you please review this Form C/A and the Crowd SAFE instrument attached as Exhibit C, in conjunction with the following summary information.

### ***Transfer Agent and Registrar***

The Company will act as transfer agent and registrar for the Securities.

### ***Not Currently Equity Interests***

The Securities are not currently equity interests in the Company and merely provide a right to receive equity at some point in the future upon the occurrence of certain events.

### ***Dividends***

The Securities do not entitle Investors to any dividends.

## *Nominee*

The nominee of the Securities shall be Republic Investment Services LLC (the “Nominee”). The Nominee will act on behalf of the Investors as their agent and proxy in all respects. The Nominee will be entitled, among other things, to exercise any voting rights (if any) conferred upon the holder of Securities or any securities acquired upon their conversion, to execute on behalf of an investor all transaction documents related to the transaction or other corporate event causing the conversion of the Securities, and as part of the conversion process the Nominee has the authority to open an account in the name of a qualified custodian, of the Nominee’s sole discretion, to take custody of any securities acquired upon conversion of the Securities. The Nominee will take direction from a pre-disclosed party selected by the Company and designated below on any matter in which affects the Investors’ economic rights. The Nominee is not a fiduciary to the Investors and the Investors agree to indemnify the Nominee per the terms of the Security.

## *Conversion*

Upon each future equity financing resulting in proceeds to the Company of not less than \$1,000,000 (each an “**Equity Financing**”), the Securities are convertible at the option of the Company, into CF Shadow Securities, which are non-voting securities otherwise identical to those issued in such future Equity Financing except (1) they do not provide the right to vote on any matters except as required by law, (2) they require Investors to vote in accordance with the majority of the investors purchasing securities from the Company in such Equity Financing with respect to any such required vote and (3) they do not provide any inspection or information rights (other than those contemplated by Regulation CF or otherwise required by law). The Company has no obligation to convert the Securities in any Equity Financing.

### *Conversion Upon the First Equity Financing*

If the Company elects to convert the Securities upon the first Equity Financing following the issuance of the Securities, the Investor will receive the number of CF Shadow Securities equal to the greater of the quotient obtained by dividing the amount the Investor paid for the Securities (the “**Purchase Amount**”) by (a) or (b) immediately below (the “**Conversion Price**”):

(a) the quotient of \$12,000,000 divided by the aggregate number of issued and outstanding equity interests, assuming full conversion or exercise of all convertible and exercisable securities then outstanding, including convertible preferred securities and all outstanding vested or unvested options or warrants to purchase equity interests, but excluding (i) equity interests reserved for future issuance under any equity incentive or similar plan, (ii) convertible promissory notes, (iii) any Simple Agreements for Future Equity, including the Securities (collectively, “**Safes**”), and (iv) any equity interests that are issuable upon conversion of any outstanding convertible promissory notes or Safes;

OR

(b) if the pre-money valuation of the Company immediately prior to the First Equity Financing is less than or equal to the Valuation Cap, the lowest price per unit of the securities sold in such Equity Financing.

Such Conversion Price shall be deemed the “**First Equity Financing Price**”.

### *Conversion After the First Equity Financing*

If the Company elects to convert the Securities upon an Equity Financing other than the first Equity Financing following the issuance of the Securities, at the Nominee’s discretion, the Investor will receive the number of CF Shadow Securities equal to the quotient obtained by dividing (a) the Purchase Amount by (b) the First Equity Financing Price.

If there are not enough funds to pay the Investor and holders of other Crowd SAFEs that failed to act as required herein (collectively, the “**Cash-Default Investors**”) in full, then all of the Company’s available funds will be allocated with equal priority and pro rata among the Cash-Default Investors to claim in proportion to their Purchase Amounts.

### *Conversion Upon a Liquidity Event Prior to an Equity Financing*

In the case of the Company undergoing an IPO (as defined below) of its Capital Stock or a Change of Control (as defined below) of the Company (either of these events, a “**Liquidity Event**”) prior to any Equity Financing, the

Investor will receive, at the option of the Nominee and within thirty (30) days of receiving notice (whether actual or constructive), either (i) a cash payment equal to the Purchase Amount subject to the following paragraph (the “**Cash Out Option**”) or (ii) a number of units of Common Securities of the Company equal to the Purchase Amount divided by the quotient of (a) \$12,000,000 divided by (b) the number, as of immediately prior to the Liquidity Event, of units of the Company’s equity interests outstanding (on an as-converted basis), assuming the exercise or conversion of all outstanding vested and unvested options, warrants and other convertible securities, but excluding: (x) units of equity interests reserved for future issuance under any equity incentive or similar plan; (y) any Safes; (z) convertible promissory notes; and (aa) any equity securities that are issuable upon conversion of any outstanding convertible promissory notes or Safes.

In connection with the Cash Out Option, the Purchase Amount (or a lesser amount as described below) will be due and payable by the Company to the Investor immediately prior to, or concurrent with, the consummation of the Liquidity Event. If there are not enough funds to pay the Investors and the holders of other Safes (collectively, the “**Cash-Out Investors**”) in full, then all of the Company’s available funds will be distributed with equal priority and pro rata among the Cash-Out Investors in proportion to their Purchase Amounts.

“**Change of Control**” as used above, means (i) a transaction or series of related transactions in which any person or group becomes the beneficial owner of more than fifty percent (50%) of the outstanding voting securities entitled to elect the Company’s board of directors, (ii) any reorganization, merger or consolidation of the Company, in which the outstanding voting security holders of the Company fail to retain at least a majority of such voting securities following such transaction or (iii) a sale, lease or other disposition of all or substantially all of the assets of the Company.

“**IPO**” means: (A) the completion of an underwritten initial public offering of Equity Interests by the Company pursuant to: (I) a final prospectus for which a receipt is issued by a securities commission of the United States or of a province of Canada, or (II) a registration statement which has been filed with the United States Securities and Exchange Commission and is declared effective to enable the sale of Capital Stock by the Company to the public, which in each case results in such equity securities being listed and posted for trading or quoted on a recognized exchange; or (B) the Company’s initial listing of its Equity Interests (other than Equity Interests not eligible for resale under Rule 144 under the Securities Act) on a national securities exchange by means of an effective registration statement on Form S-1 filed by the Company with the SEC that registers existing Equity Interests of the Company for resale, as approved by the Company’s board of managers, where such listing shall not be deemed to be an underwritten offering and shall not involve any underwriting services; or (C) the completion of a reverse merger or take-over whereby an entity (I) whose securities are listed and posted for trading or quoted on a recognized exchange, or (II) is a reporting issuer in the United States or the equivalent in any foreign jurisdiction, acquires all of the issued and outstanding Equity Interests of the Company.

#### *Conversion Upon a Liquidity Event Following an Equity Financing*

In the case of a Liquidity Event following any Equity Financing, the Investor will receive, at the option of the Nominee and within thirty (30) days of receiving notice (whether actual or constructive), either (i) the Cash Out Option or (ii) a number of units of the most recently issued equity interests equal to the Purchase Amount divided by the First Equity Financing Price. Units of equity interests granted in connection therewith shall have the same liquidation rights and preferences as the units of equity interests issued in connection with the Company’s most recent Equity Financing.

If there are not enough funds to pay the Investors and the other Cash-Out Investors in full, then all of the Company’s available funds will be distributed with equal priority and pro rata among the Cash-Out Investors in proportion to their Purchase Amounts.

If the Company’s managers (or board of directors if the Company subsequently becomes a corporation) determine in good faith that delivery of equity interests to the Investor pursuant to Liquidity Event paragraphs above would violate applicable law, rule or regulation, then the Company shall deliver to Investor in lieu thereof, a cash payment equal to the fair market value of such equity interests, as determined in good faith by the Company’s board of directors (or other applicable governing body if the Company is a limited liability company).

#### ***Dissolution***

If there is a Dissolution Event (as defined below) before the Securities terminate, subject to the preferences applicable to any series of Preferred Securities then outstanding, the Company will distribute all proceeds legally available for

distribution with equal priority among the (i) holders of the Securities (on an as converted basis based on a valuation of Common Securities as determined in good faith by the Company's board of managers (or board of directors if the Company subsequently becomes a corporation) at the time of the Dissolution Event), (ii) all other holders of instruments sharing in the distribution of proceeds of the Company at the same priority as holders of Common Securities upon a Dissolution Event and (iii) all holders of Common Securities.

A “**Dissolution Event**” means (i) a voluntary termination of operations by the Company, (ii) a general assignment for the benefit of the Company's creditors or (iii) any other liquidation, dissolution or winding up of the Company (excluding a Liquidity Event), whether voluntary or involuntary.

### ***Termination***

The Securities terminate upon (without relieving the Company of any obligations arising from a prior breach of or non-compliance with the Securities) upon the earlier to occur of: (i) the issuance of units in the CF Shadow Securities to the Investor pursuant to the conversion provisions of the Crowd SAFE agreement or (ii) the payment, or setting aside for payment, of amounts due to the Investor pursuant to a Liquidity Event or a Dissolution Event.

### ***Voting and Control***

Neither the Securities nor the securities issuable upon the conversion of the Securities have voting rights. In addition, to facilitate the Offering to Crowd SAFE Investors being able to act together and cast a vote as a group, to the extent any securities acquired upon conversion of the Securities confer the holder with voting rights (whether provided by the Company's governing documents or by law), the Nominee (as defined above) will act on behalf of the holders as agent and proxy in all respects. The Nominee will vote consistently at the direction of the Chief Executive Officer of the Company.

The Company does not have any voting agreements in place.

The Company does not have any member or equity holder agreements in place, except for an LLC Operating Agreement, dated May 10, 2021.

### ***Anti-Dilution Rights***

The Securities do not have anti-dilution rights, which means that future equity issuances and other events will dilute the ownership percentage that the Investor may eventually have in the Company.

### ***Restrictions on Transfer***

Any Securities sold pursuant to Regulation CF being offered may not be transferred by any Investor of such Securities during the one-year holding period beginning when the Securities were issued, unless such Securities are transferred: (1) to the Company; (2) to an accredited investor, as defined by Rule 501(d) of Regulation D promulgated under the Securities Act; (3) as part of an IPO; or (4) to a member of the family of the Investor or the equivalent, to a trust controlled by the Investor, to a trust created for the benefit of a member of the family of the Investor or the equivalent, or in connection with the death or divorce of the Investor or other similar circumstances. “Member of the family” as used herein means a child, stepchild, grandchild, parent, stepparent, grandparent, spouse or spousal equivalent, sibling, mother/father/daughter/son/sister/brother-in-law, and includes adoptive relationships. Each Investor should be aware that although the Securities may legally be able to be transferred, there is no guarantee that another party will be willing to purchase them.

In addition to the foregoing restrictions, prior to making any transfer of the Securities or any equity interests into which they are convertible, such transferring Investor must either make such transfer pursuant to an effective registration statement filed with the SEC or provide the Company with an opinion of counsel reasonably satisfactory to the Company stating that a registration statement is not necessary to effect such transfer.

In addition, the Investor may not transfer the Securities or any equity interests into which they are convertible to any of the Company's competitors, as determined by the Company in good faith.

Furthermore, upon the event of an IPO, the equity interests into which the Securities are converted will be subject to a lock-up period and may not be lent, offered, pledged, or sold for up to 180 days following such IPO.

#### ***Other Material Terms***

- The Company does not have the right to repurchase the Securities.
- The Securities do not have a stated return or liquidation preference.

#### **COMMISSION AND FEES**

At the conclusion of the Offering, the issuer shall pay a fee of six percent (6%) of the amount raised in the Offering to the Intermediary.

#### **Stock, Warrants and Other Compensation**

The Intermediary will also receive compensation in the form of securities equal to two percent (2%) of the total number of the Securities sold in the Offering.

#### **TAX MATTERS**

**EACH PROSPECTIVE INVESTOR SHOULD CONSULT WITH THEIR OWN TAX AND ERISA ADVISOR AS TO THE PARTICULAR CONSEQUENCES TO THE INVESTOR OF THE PURCHASE, OWNERSHIP AND SALE OF THE INVESTOR'S SECURITIES, AS WELL AS POSSIBLE CHANGES IN THE TAX LAWS.**

**TO ENSURE COMPLIANCE WITH THE REQUIREMENTS IMPOSED BY THE INTERNAL REVENUE SERVICE, WE INFORM YOU THAT ANY TAX STATEMENT IN THIS FORM C/A CONCERNING UNITED STATES FEDERAL TAXES IS NOT INTENDED OR WRITTEN TO BE USED, AND CANNOT BE USED, BY ANY TAXPAYER FOR THE PURPOSE OF AVOIDING ANY TAX-RELATED PENALTIES UNDER THE UNITED STATES INTERNAL REVENUE CODE. ANY TAX STATEMENT HEREIN CONCERNING UNITED STATES FEDERAL TAXES WAS WRITTEN IN CONNECTION WITH THE MARKETING OR PROMOTION OF THE TRANSACTIONS OR MATTERS TO WHICH THE STATEMENT RELATES. EACH TAXPAYER SHOULD SEEK ADVICE BASED ON THE TAXPAYER'S PARTICULAR CIRCUMSTANCES FROM AN INDEPENDENT TAX ADVISOR.**

**Potential Investors who are not United States residents are urged to consult their tax advisors regarding the United States federal income tax implications of any investment in the Company, as well as the taxation of such investment by their country of residence. Furthermore, it should be anticipated that distributions from the Company to such foreign investors may be subject to United States withholding tax.**

**EACH POTENTIAL INVESTOR SHOULD CONSULT THEIR OWN TAX ADVISOR CONCERNING THE POSSIBLE IMPACT OF STATE TAXES.**

#### **LEGAL MATTERS**

Any prospective Investor should consult with its own counsel and advisors in evaluating an investment in the Offering.

#### **DISCLAIMER OF TELEVISION, RADIO, PODCAST AND STREAMING PRESENTATION**

The Company's officers may participate in the filming or recording of a various media and in the course of the filming, may present certain business information to the investor panel appearing on the show (the "**Presentation**"). The Company will not pass upon the merits of, certify, approve, or otherwise authorize the statements made in the Presentation. The Presentation commentary being made should not be viewed as superior or a substitute for the disclosures made in this Form-C. Accordingly, the statements made in the Presentation, unless reiterated in the Offering materials provided herein, should not be applied to the Company's business and operations as of the date of

this Offering. Moreover, the Presentation may involve several statements constituting puffery, that is, exaggerations not to be taken literally or otherwise as indication of factual data or historical or future performance.

#### **ADDITIONAL INFORMATION**

The summaries of, and references to, various documents in this Form C/A do not purport to be complete and in each instance reference should be made to the copy of such document which is either an appendix to this Form C/A or which will be made available to Investors and their professional advisors upon request.

Prior to making an investment decision regarding the Securities described herein, prospective Investors should carefully review and consider this entire Form C/A. The Company is prepared to furnish, upon request, a copy of the forms of any documents referenced in this Form C/A. The Company's representatives will be available to discuss with prospective Investors and their representatives and advisors, if any, any matter set forth in this Form C/A or any other matter relating to the Securities described in this Form C/A, so that prospective Investors and their representatives and advisors, if any, may have available to them all information, financial and otherwise, necessary to formulate a well-informed investment decision. Additional information and materials concerning the Company will be made available to prospective Investors and their representatives and advisors, if any, at a mutually convenient location upon reasonable request.

## SIGNATURE

Pursuant to the requirements of Sections 4(a)(6) and 4A of the Securities Act of 1933 and Regulation Crowdfunding (§ 227.100 et seq.), the issuer certifies that it has reasonable grounds to believe that it meets all of the requirements for filing on Form C/A and has duly caused this Form C/A to be signed on its behalf by the duly authorized undersigned.

/s/Sean Jones

\_\_\_\_\_  
(Signature)

Sean Jones

\_\_\_\_\_  
(Name)

Chief Executive Officer

\_\_\_\_\_  
(Title)

Pursuant to the requirements of Sections 4(a)(6) and 4A of the Securities Act of 1933 and Regulation Crowdfunding (§ 227.100 et seq.), this Form C/A has been signed by the following persons in the capacities and on the dates indicated.

/s/Sean Jones

\_\_\_\_\_  
(Signature)

Sean Jones

\_\_\_\_\_  
(Name)

Managing Member

\_\_\_\_\_  
(Title)

March 28, 2022

\_\_\_\_\_  
(Date)

### ***Instructions.***

1. The form shall be signed by the issuer, its principal executive officer or officers, its principal financial officer, its controller or principal accounting officer and at least a majority of the board of directors or persons performing similar functions.
2. The name of each person signing the form shall be typed or printed beneath the signature. Intentional misstatements or omissions of facts constitute federal criminal violations. See 18 U.S.C. 1001.

**EXHIBIT A**

*Financial Statements*





**QuickLoadz Container System, LLC.**

Unaudited financial statements  
for years ended December 31, 2020 and 2019.

With independent accountant's review report

**QuickLoadz Container System, LLC.**  
**Table of contents**  
**For years ended December 31, 2020 and 2019**  
**(Unaudited)**

---

	<b>Page</b>
Independent accountant's review report	2
Balance sheets	3
Income statements	4
Statements of changes in proprietor's capital	5
Statements of cash flows	6
Notes to the financial statements	7-14

**QuickLoadz Container System, LLC.**  
**Independent accountant's review report**  
**For years ended December 31, 2020 and 2019**  
**(Unaudited)**

---

Sean D. Jones  
QuickLoadz Container System, LLC.  
The Plains, OH

We have reviewed the accompanying financial statements of QuickLoadz Container System, LLC. (a proprietorship), which comprise the balance sheets as of December 31, 2020, and 2019 and the related statements of income, changes in proprietor's capital, and cash flows for the years then ended, and the related notes to the financial statements. A review includes primarily applying analytical procedures to owner's financial data and making inquiries of owner. A review is substantially less in scope than an audit, the objective of which is the expression of an opinion regarding the financial statements taken as a whole. Accordingly, we do not express such an opinion.

Management is responsible for the preparation and fair presentation of these financial statements in accordance with accounting principles generally accepted in the United States of America; this includes the design, implementation, and maintenance of internal control relevant to the preparation and fair presentation of financial statements that are free from material misstatement whether due to fraud or error.

*Accountant's responsibility*

Our responsibility is to conduct the review engagement in accordance with Statements on Standards for Accounting and Review Services promulgated by the Accounting and Review Services Committee of the AICPA. Those standards require us to perform procedures to obtain limited assurance as a basis for reporting whether we are aware of any material modifications that should be made to the financial statements for them to be in accordance with accounting principles generally accepted in the United States of America. We believe that the results of our procedures provide a reasonable basis for our conclusion.

*Accountant's conclusion*

Based on our review, we are not aware of any material modification that should be made to the accompanying financial statements in order for them to be in conformity with accounting principles generally accepted in the United States of America.

*Going concern*

The accompanying financial statements have been prepared assuming that the company will continue as a going concern. As discussed in the notes, certain conditions raise an uncertainty about the company's ability to continue as a going concern. The accompanying financial statements do not include any adjustments that might result from the outcome of this uncertainty. Our conclusion is not modified with respect to this matter.

*Rick Jarve*

Ricardo Jarve  
Tulsa, OK  
October 10, 2021

**QuickLoadz Container System, LLC.**  
**Balance sheets**  
**As of December 31, 2020, and 2019**  
**Expressed in US\$**  
**(Unaudited)**

	<u>2020</u>	<u>2019</u>
<b>Assets</b>		
Current assets		
Cash and cash equivalents	182,122	913,107
Accounts receivable	3,087	-
Inventory	522,393	451,271
Total current assets	<u>707,602</u>	<u>1,364,378</u>
Non-current assets		
Debt issuance cost	164,593	169,919
Property and equipment	1,220,630	463,977
Intangibles	147,262	119,633
Total non-current assets	<u>1,532,485</u>	<u>753,529</u>
Total assets	<u><u>2,240,087</u></u>	<u><u>2,117,907</u></u>
 <b>Liabilities and proprietor's capital</b>		
<b>Liabilities</b>		
Current liabilities		
Accounts payable	124,541	108,323
Loans	428,583	121,962
Advances from customers	15,000	14,044
Notes payables	-	100,000
Total current liabilities	<u>568,124</u>	<u>344,329</u>
Non-current liabilities		
Loans	2,466,157	2,784,644
Total non-current liabilities	<u>2,466,157</u>	<u>2,784,644</u>
Total liabilities	<u>3,034,281</u>	<u>3,128,973</u>
<b>Proprietor's capital</b>		
Capital	2,415,334	2,328,524
Accumulated deficit	(3,209,528)	(3,339,590)
Total proprietor's capital	<u>(794,194)</u>	<u>(1,011,066)</u>
Total liabilities and proprietor's capital	<u><u>2,240,087</u></u>	<u><u>2,117,907</u></u>

*See independent accountant's review report and the notes to the financial statements*

QuickLoadz Container System, LLC.  
**Income statements**  
**For years ended December 31, 2020 and 2019**  
**Expressed in US\$**  
**(Unaudited)**

---

	<u>2020</u>	<u>2019</u>
Sales	1,002,474	703,706
Cost of goods sold	<u>687,266</u>	<u>511,559</u>
Gross profit	<u>315,208</u>	<u>192,147</u>
<b>Operating expenses</b>		
Payroll expenses	484,651	340,910
General and administrative	289,846	210,251
Depreciation and amortization	87,442	65,855
Sales and marketing	<u>57,274</u>	<u>27,401</u>
Total operating expenses	<u>919,213</u>	<u>644,417</u>
Net operating loss	<u>(604,005)</u>	<u>(452,270)</u>
<b>Non-operating (expenses) income</b>		
Other income	307,479	-
Grant income	599,475	63,841
Interest expenses	<u>(172,887)</u>	<u>(108,991)</u>
Total non-operating income (expenses)	<u>734,067</u>	<u>(45,150)</u>
Net income (loss)	<u>130,062</u>	<u>(497,420)</u>

*See independent accountant's review report and the notes to the financial statements*

QuickLoadz Container System, LLC.  
 Statements of changes in proprietor's capital  
 For years ended December 31, 2020 and 2019  
 Expressed in US\$  
 (Unaudited)

	Capital	Accumulated deficit	Total proprietor's capital
<b>Beginning balance, January 1, 2019</b>	1,738,767	(2,842,170)	(1,103,403)
Additional capital contributed	589,757	-	589,757
Net loss	-	(497,420)	(497,420)
<b>Ending balance, December 31, 2019</b>	<b>2,328,524</b>	<b>(3,339,590)</b>	<b>(1,011,066)</b>
Additional capital contributed	86,810	-	86,810
Net income	-	130,062	130,062
<b>Ending balance, December 31, 2020</b>	<b>2,415,334</b>	<b>(3,209,528)</b>	<b>(794,194)</b>

*See independent accountant's review report and the notes to the financial statements*

QuickLoadz Container System, LLC.  
**Statements of cash flows**  
**For years ended December 31, 2020 and 2019**  
**Expressed in US\$**  
**(Unaudited)**

	<b>2020</b>	<b>2019</b>
<b>Cash flows from operating activities</b>		
Net income (loss)	130,062	(497,420)
Adjustments to reconcile net income (loss) to net cash provided (used) for operations:		
Depreciation and amortization	87,442	65,855
(Increase) decrease in assets		
Accounts receivable	(3,087)	-
Inventory	(71,122)	(301,741)
Other current assets	-	62,600
Debt issuance cost	5,326	(151,727)
Increase (decrease) in liabilities		
Accounts payable	16,218	37,713
Advances from customers	956	(33,141)
Cash flows provided (used) in operating activities	<u>165,795</u>	<u>(817,861)</u>
<b>Cash flows from investing activities</b>		
Purchase of property and equipment	(834,724)	(426,911)
Purchase of intangibles	(37,000)	(16,771)
Cash flows used in investing activities	<u>(871,724)</u>	<u>(443,682)</u>
<b>Cash flows from financing activities</b>		
Loans	(11,866)	1,433,159
Notes payables	(100,000)	100,000
Additional capital contributed	86,810	589,757
Cash flows (used) provided by investing activities	<u>(25,056)</u>	<u>2,122,916</u>
Net (decrease) increase in cash	(730,985)	861,373
Cash at beginning of year	<u>913,107</u>	<u>51,734</u>
Cash at end of year	<u><u>182,122</u></u>	<u><u>913,107</u></u>

*See independent accountant's review report and the notes to the financial statements*

## **1. Nature of operations**

QuickLoadz Container System, LLC. (the "company" or "QuickLoadz") is an Ohio limited liability company registered on April 5, 2013. The company was founded to develop and market a patented container delivery system, as well as to provide mobile storage using container delivery system. QuickLoadz's methods and ideas provide for a safer, smarter, faster way to move ISO shipping containers. The Company's headquarters are located in Athens, Ohio, and began operations in 2013.

## **2. Summary of significant accounting policies**

### *Basis of presentation*

The accompanying financial statements have been prepared in accordance with U.S. Generally Accepted Accounting Principles (US GAAP). The accompanying unaudited financial statements do not include all the information and notes required by US GAAP for complete financial statements. In the opinion of management, all adjustments considered necessary for the fair presentation of the unaudited financial statements for the years presented have been included.

### *Fiscal year*

The company operates on a December 31<sup>st</sup> year-end.

### *Going concern*

The financial statements are prepared on a going concern basis. The company's ability to continue depends on management's plans to raise additional funds and achieve profitable operations. The financial statements do not include any adjustments that might be necessary if the company is not able to continue as a going concern.

### *Use of estimates*

The preparation of the financial statement in conformity with US GAAP, requires the use of management's estimates. These estimates are subjective in nature and involve judgments that affect the reported in the financial statements and footnotes thereto. Actual results could materially differ from these estimates. It is reasonably possible that changes in estimates will occur in the near term.

### *Risks and uncertainties*

The company's business and operations are sensitive to general business and economic conditions in the United States. Several factors beyond the company's control may cause fluctuations in these conditions. Adverse conditions may include recession, downturn or otherwise, local competition or changes in consumer taste. These adverse conditions could affect the company's financial condition and the results of its operations.



**QuickLoadz Container System, LLC.**  
**Notes to the financial statements**  
**For years ended December 31, 2020 and 2019**  
**Expressed in US\$**  
**(Unaudited)**

---

The COVID-19 Pandemic has negatively impacted the macroeconomic environment in the U.S. and globally. This business, in particular, has been affected - including its operations and financial condition. Due to the evolving and uncertain nature of COVID-19, it is reasonably possible that it could materially impact the financial statements estimates, particularly those that require consideration of forecasted financial information.

The magnitude of the impact that COVID-19 has on the business going forward will depend on numerous evolving factors that we may not be able to accurately predict nor control - including the duration and extent of the pandemic; the impact of federal, state, local, and foreign governmental actions; changes in consumer behavior in response to the pandemic and such governmental actions; and economic and operating conditions faced in the pandemic's aftermath.

*Concentrations of credit risk in cash and cash equivalents*

The company maintains its cash balance in five financial institution. The balance is insured by the Federal Deposit Insurance Corporation up to \$250,000. At various times during the fiscal year, the company's cash in bank balances exceeded the Federally insured limits. As of December 31, 2020, and 2019, the company had \$ 182,122 and \$913,107 of cash and cash equivalents, respectively.

*Accounts receivable*

The company's trade receivables are recorded when billed and represent claims against third parties that will be settled in cash. The carrying value of the company's receivables, net of the allowance for doubtful accounts, represents their estimated net realizable value. As of December 31, 2020, the company had \$3,087 in account receivables.

*Inventory*

Inventories are stated at the lower of cost and net realizable value. Cost included those overheads that have been incurred in bringing the inventories to their present location and condition. Cost is calculated using the weighted average method. Net realizable value represents the estimated selling price less all estimated costs of completion and costs to be incurred in marketing, selling and distribution.

*Property and equipment*

Property and equipment are stated at cost. Depreciation is computed using the straight-line method over the estimated useful lives of the assets between 5 and 39 years. Expenditures for renewals and improvements that significantly add to the productive capacity or extend the useful life of an asset are capitalized. Repair and maintenance costs are charged to operations as incurred and major improvements are capitalized.

The company reviews the carrying value of property and equipment for impairment whenever events and circumstances indicate that the carrying value of an asset may not be recoverable from the estimated future cash flows expected to result from its use and

**QuickLoadz Container System, LLC.**  
**Notes to the financial statements**  
**For years ended December 31, 2020 and 2019**  
**Expressed in US\$**  
**(Unaudited)**

---

eventual disposition. There were no impairment losses during the years ended December 31, 2020 and 2019.

Property and equipment consisted of the following as of December 31, 2020, and 2019:

	<b>2020</b>	<b>2019</b>
Trailers	20,046	20,046
Vehicles	70,300	70,300
Equipment	789,835	733,346
Building	300,000	299,603
Leasehold improvements	808,641	32,875
Property and equipment, gross	<u>1,988,822</u>	<u>1,156,170</u>
Accumulated depreciation	<u>(768,192)</u>	<u>(692,193)</u>
Property and equipment, net	<u><u>1,220,630</u></u>	<u><u>463,977</u></u>

*Intangibles*

Intangible assets are amortized using the straight-line method over the estimated useful lives of the assets between 3 and 15 years. The company periodically evaluates the recoverability of intangible assets and takes into account events or circumstances that warrant revised estimates of useful lives or that may indicate that impairments exist. There were no impairment losses during the years ended December 31, 2020 and 2019.

Intangibles consisted of the following as of December 31, 2020, and 2019:

	<b>2020</b>	<b>2019</b>
Patent	148,127	133,933
Software license	33,560	8,682
Intangibles, gross	<u>181,687</u>	<u>142,615</u>
Accumulated amortization	<u>(34,425)</u>	<u>(22,982)</u>
Intangibles, net	<u><u>147,262</u></u>	<u><u>119,633</u></u>

*Debt issuance cost*

Debt issuance costs are amortized over the period the related obligation is outstanding using the straight-line method which is a reasonable estimate of the effective interest method. Debt issuance cost incurred on the issuance of the company's loans are included within non-current assets on the balance sheets. As of December 31, 2020, and 2019, amortization of debt issuance cost is included in interest expense in the accompanying financial statements.

**QuickLoadz Container System, LLC.**  
**Notes to the financial statements**  
**For years ended December 31, 2020 and 2019**  
**Expressed in US\$**  
**(Unaudited)**

---

*Fair value measurements*

Generally accepted accounting principles define fair value as the price that would be received to sell an asset or be paid to transfer a liability in an orderly transaction between market participants at the measurement date (exit price) and such principles also establish a fair value hierarchy that prioritizes the inputs used to measure fair value using the following definitions (from highest to lowest priority):

- Level 1: Unadjusted quoted prices in active markets that are accessible at the measurement date for identical, unrestricted assets or liabilities,
- Level 2: Observable inputs other than quoted prices included within Level 1 that are observable for the asset or liability, either directly or indirectly, including quoted prices for similar assets and liabilities in active markets; quoted prices for identical or similar assets and liabilities in markets that are not active; or other inputs that are observable or can be corroborated by observable market data by correlation or other means,
- Level 3: Prices or valuation techniques requiring inputs that are both significant to the fair value measurement and unobservable.

*Revenue recognition*

Revenues are recognized when persuasive evidence of an arrangement existed, delivery of products had occurred, the sales price was fixed or determinable and collectability was reasonably assured. The company records revenue from the sale of its products when risk of loss and title to the products transfers to the customer. Net sales are comprised of gross revenues less expected product returns, trade discounts and customer allowances, which include costs associated with off-invoice mark-downs and other price reductions.

*Income taxes*

Income from the proprietorship is combined with the income and expenses of the proprietor from other sources and reported in the proprietor's individual federal and state income tax returns. The proprietorship is not a taxpaying entity for purposes of federal and state income taxes, and thus no income taxes have been recorded in the statements. The proprietor customarily makes estimated tax payments toward his personal income tax liability from the proprietorship bank account. These payments are treated as withdrawals of capital.

*Recent accounting pronouncements*

From time to time, new accounting pronouncements are issued by the Financial Accounting Standards Board, or FASB, or other standard-setting bodies and adopted by the company as of the specified effective date. Unless otherwise determined, the company believes that the impact of recently issued standards that are not yet effective will not have a material impact on its financial position or results of operations upon adoption.

**QuickLoadz Container System, LLC.**  
**Notes to the financial statements**  
**For years ended December 31, 2020 and 2019**  
**Expressed in US\$**  
**(Unaudited)**

---

**3. Inventory**

Inventory consisted of the following as of December 31, 2020, and 2019:

	<b>2020</b>	<b>2019</b>
Raw material	495,393	424,271
Others	27,000	27,000
	<u>522,393</u>	<u>451,271</u>

**4. Accounts payables**

Accounts payables consisted of the following as of December 31, 2020, and 2019:

	<b>2020</b>	<b>2019</b>
Suppliers	<u>124,541</u>	<u>108,323</u>

Accounts payable consist of obligations of the company to suppliers of goods and services obtained in the ordinary course of business.

**5. Loans**

Loans consisted of the following as of December 31, 2020, and 2019:

	<b>2020</b>	<b>2019</b>
Current		
BizCapital BIDCO I, LLC	410,744	97,350
Small Business Administration	496	-
Ohio University Credit Union	8,747	2,830
Credit cards	8,596	21,782
Current	<u>428,583</u>	<u>121,962</u>
Non-current		
BizCapital BIDCO I, LLC	2,356,906	2,767,650
Small Business Administration	101,004	-
Ohio University Credit Union	8,247	16,994
Non-current	<u>2,466,157</u>	<u>2,784,644</u>
Loans	<u>2,894,740</u>	<u>2,906,606</u>

**QuickLoadz Container System, LLC.**  
**Notes to the financial statements**  
**For years ended December 31, 2020 and 2019**  
**Expressed in US\$**  
**(Unaudited)**

---

*BizCapital BIDCO I, LLC*

On June 25, 2019, the company received \$2,865,000 as a loan by a promissory note from BizCapital BIDCO I, LLC, a loan facilitated by the Small Business Administration (SBA) upon the company's application. The interest rate on the note fluctuates, and the initial interest rate was 8.25%, which is the prime rate in effect on the first business day of the month in which the SBA received the loan application, plus 2.75%. The company agreed to pay principal and interest payments of \$28,809 every month, beginning thirteen months after the aforementioned date of the note, and all remaining principal and accrued interest is due and payable 15 years from date of initial disbursement. As of December 31, 2020, and 2019, the remaining balance was \$2,767,650 and 2,865,000, respectively. During the years ended December 31, 2020, and 2019, interest expenses from this loan were \$147,140 and \$60,250, respectively.

*Small Business Administration*

On April 21, 2020, the company entered into a loan authorization and agreement with the SBA, as part of the federal government's COVID-19 Economic Injury Disaster Loan program, by which it received a loan of \$101,500, with an interest rate of 3.75% per annum. The company agreed to installment payments, including principal and interest, of \$496 per month, and the balance of principal and interest will be payable thirty (30) years from the date of the promissory note. As of December 31, 2020, the remaining balance was \$101,500.

*Ohio University Credit Union*

On September 20, 2019, the company entered into and signed a disbursement request and authorization, a promissory note, a business loan agreement, a limited liability company resolution to borrow/grant collateral, a commercial guaranty, a commercial security agreement, and an errors and omissions agreement, all by which the company received from Ohio University Credit Union a loan with a principal balance of \$21,165, with an interest rate on the unpaid principal balance of 5.49% per annum until paid in full. The maturity date was agreed to be October 1, 2023, and the company will pay such loan in 47 monthly payments of \$493 each. As of December 31, 2020, and 2019, the remaining balance was \$16,994 and 19,824, respectively. During the years ended December 31, 2020, and 2019, interest expenses from this loan were \$996 and \$381, respectively.

*Credit cards*

Credit cards accrue interest at a market rate.

**6. Advances from customers**

As of December 31, 2020, and 2019, the company maintains advances no older than a month received from customers for \$15,000 and \$14,044 respectively.

## **7. Notes payables**

On November 29, 2019, the company and Sean Jones entered into a secured promissory note with Sugarbush Valley, LLC, whereby both the company and Sean Jones promised to pay a total of \$100,000 as a principal amount, plus an interest of 8% per annum, plus an origination fee of \$1,000. The maturity period of such note was initially 90 days, until February 29, 2020. On April 6, 2020, the parties issued an addendum in which they agreed to extend the maturity period from February 29, 2020, until August 29, 2020, without such extension constituting a default or otherwise entailing any penalty whatsoever for the company and for Sean Jones. On November 6, 2020, this debt was fully paid.

## **8. Proprietor's capital**

The company's operating agreement was entered into by the company and Sean Jones as a single member and manager, with an initial contribution of \$350,000 in 2013 for 100% of membership interest.

As of December 31, 2020, and 2019, the proprietor made net contributions to the capital for \$589,757 and \$ 86,810, respectively.

## **9. Grants**

During 2020 and 2019, the company received grants from the State of Ohio, Development Services Agency totaling an amount of \$599,475, as financial assistance to the company for wages paid for an approved Ohio diversity and inclusion technology internship.

These grants were subject to conditions and satisfaction of legal and regulatory requirements in order to complete milestones. The company assessed that there is reasonable assurance that it will comply with the conditions attached to the grant. Grant income is recognized in the income statements on a systematic basis over the period established by the grant conditions.

## **10. Subsequent events**

### *Membership*

In May 2021, the company entered into a capital contribution and membership agreement with Sugarbush Valley, LLC and Legacy Property Holdings, Ltd., whereby both of such firms made capital contributions to and became members of the company. Sugarbush Valley, LLC became a member upon conversion of a certain note from the company dated June 30, 2017, with the principal amount and accrued interests totaling \$159,062, representing a 1.325% of membership interest. Legacy Property Holdings, Ltd. became a member of the company after paying \$160,000 in cash, with a 01.333% of membership interest. In May 2021, the company updated its operating agreement to reveal its membership interest in

**QuickLoadz Container System, LLC.**  
**Notes to the financial statements**  
**For years ended December 31, 2020 and 2019**  
**Expressed in US\$**  
**(Unaudited)**

---

accordance with the aforementioned agreements. Membership interest is currently divided as follows: Sean Jones (77.341%); Bridget M. Lair (20%); Sugarbush Valley LLC (1.325%), and; Legacy Property Holdings, Ltd. (1.333%).

*Crowdfunding offering.*

The company is offering (the "crowdfunded offering") up to \$1,070,000 in Simple Agreements for Future Equity (SAFEs). The company is attempting to raise a minimum amount of \$25,000 in this offering and up to \$1,070,00 maximum. The company must receive commitments from investors totaling the minimum amount by the offering deadline listed in the Form C, as amended in order to receive any found.

The crowdfunded offering is being made through OpenDeal Inc. (the "intermediary" aka "Republic" or "Republic.co"). The intermediary will be entitled to receive a 6% commission fee and 2% of the securities issued in the offering.

*Management's evaluation*

Management has evaluated subsequent events through October 10, 2021, the date the financial statements were available to be issued. Based on this evaluation, no additional material events were identified which require adjustment or disclosure in the financial statements.

**EXHIBIT B**

*Offering Page found on Intermediary's Portal.*



**Company Name** QuickLoadz

**Logo**



**Headline** Smartphone-controlled robotic trailers for faster, safer, easier shipping

**Hero Image**



**Tags**

**Pitch text**

### Summary

- Potential to open the bottleneck for 90% of the worlds freight
- Total addressable market of \$9.6T+
- Solves final-mile distribution problems faced by companies like Amazon
- Computer controlled, Wi-Fi enabled system automates container movement
- Aiming to save large freight end-users billions of dollars annually
- All-electric product with Hybrid Power Axle system coming soon

## Problem

# Inefficient freight transport increases costs and drags on the global economy

**90% of the world's freight** travels in over 150,000,000 sea shipping containers. This merchandise can only be loaded or unloaded at loading docks and handled with expensive equipment at special facilities. This bottlenecks freight and logistics worldwide and chokes the world economy.



## Solution

# An automated way to move sea shipping containers

*without any additional equipment*

**QuickLoadz Intermodal Robotics smartphone-controlled trailers** are built to move the world's **168,000,000 ISO containers** faster, safer, and easier than ever before—expanding freight and **greatly improving efficiencies**.

Our hardware consists of a Wi-Fi-enabled, **computer-controlled trailer** that the driver operates from their smartphone. A driver can **load or unload 60,000 lbs.** of merchandise in **3 minutes** without ever leaving their seat in the truck cab.





**Controlled with the driver's smartphone.**

**Lift Wedges raise the container over the bed.**

**Built-in chains hook into the container corners.**

**The bed is pulled underneath the container.**

**Hydraulic locks slide into the container corners instantly.**

**Loading takes just three minutes with no manual labor.**

This Wi-Fi-controlled trailer lends itself to easy coupling with any driver in any truck. It makes easy control of the system for Autonomous Trucks such as TuSimple, Waymo, Plus, Kodiak, Tesla, or Embark.

## Everyone's excited about the self-driving truck.



T E S L A +

**QuickLoadz**



WAYMO



LOCOMOTION

**But the trailer is what makes the magic happen in shipping.**

By pairing these innovations together, QuickLoadz can turn shipping upside down.

### Product

## Truck beds and trailers that automate the movement of shipping containers

The QuickLoadz system consists of a patented mechanical system that uses the structure of any standard ISO sea shipping container to load/unload:



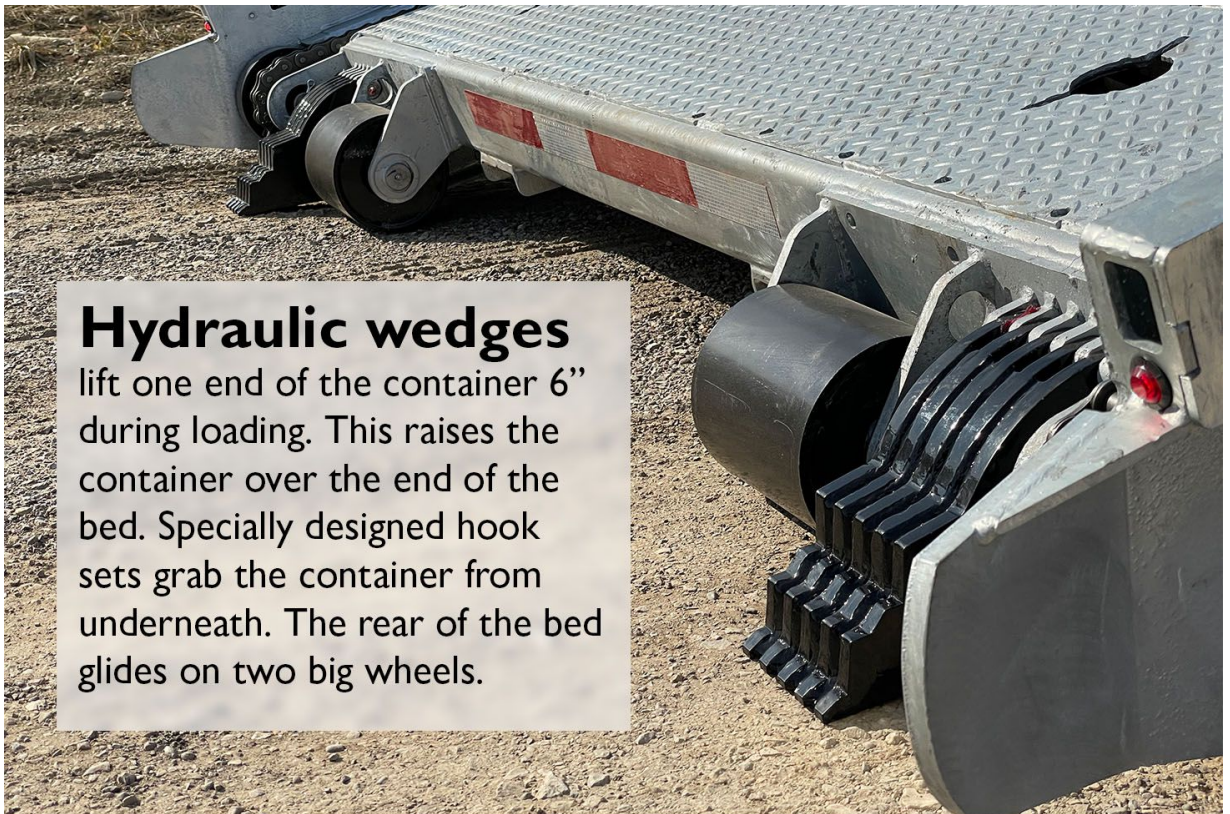

## Hydraulic wedges

lift one end of the container 6" during loading. This raises the container over the end of the bed. Specially designed hook sets grab the container from underneath. The rear of the bed glides on two big wheels.



## Both hooks

pull the bed under the stationary container. The container is pulled all the way to the front of the bed, and locked on with hydraulically-actuated pins.



## The bed tilts

back down and is ready to go in three minutes or less. This deceptively simple mechanism is the result of years of research and development.





This mechanism contains sophisticated mechanical processes to make the whole system work smoothly, a large part of our “secret sauce.”

The hardware portions of the system are patent-protected in countries all over the world, providing a deep moat against newcomers.

## The Brain Box

consists of a computer, Wi-Fi network and HD video processors for the available 6 camera inputs. The QuickLoadz Brain Box is also equipped to add GPS (location), GSM (cellular communications) and has room for future blank add-on boards.



This Brain Box controls a very sophisticated hydraulic control block that allows software control of both pressure and flow of hydraulics. In this way, units are universal between QuickLoadz models with different parameters set in the software. This system will also allow future “push and pull” of updates, locations and data much like Tesla.

# QuickLoadz Intermodal Robotics beds

are designed for mass manufacture. Across 10 different models ranging from 16,000 to 60,000 pound GVWR and 20' to 40' in length, the patented QuickLoadz hardware is standardized. Therefore, beds can be manufactured in mass and quickly assembled onto the frames needed for current orders.

In this way, QuickLoadz moves away from the need to stock finished trailers and can quickly build to order.



**The 24k Super 20**  
20' trailer for pickup trucks



**The 26k Super 40**  
40' trailer for pickup trucks



**The 40k Super Bed**  
Bed mounted on medium truck



**The 60k Super High 40**  
Trailer for big freight

## Traction

### QuickLoadz has been in hands of customers since 2015

*Thousands of containers moved, millions of miles traveled. Field testing is done. **Time to scale.***

- Current billion dollar enterprise-level customers.
- Multiple multi-unit orders.
- Sales usually doubling every year. Even in 2020, sales went up 43%.
- Development agreements with cutting-edge companies solving the world's last-mile delivery problems, such as Vaqari.
- Development agreement with self contained tiny home manufacturer Piedmont Green.
- Winner of awards from TechGrowth Ohio to Beijing, China.
- QuickLoadz units are trusted from Northern Canada to the United Arab Emirates.

# Sales

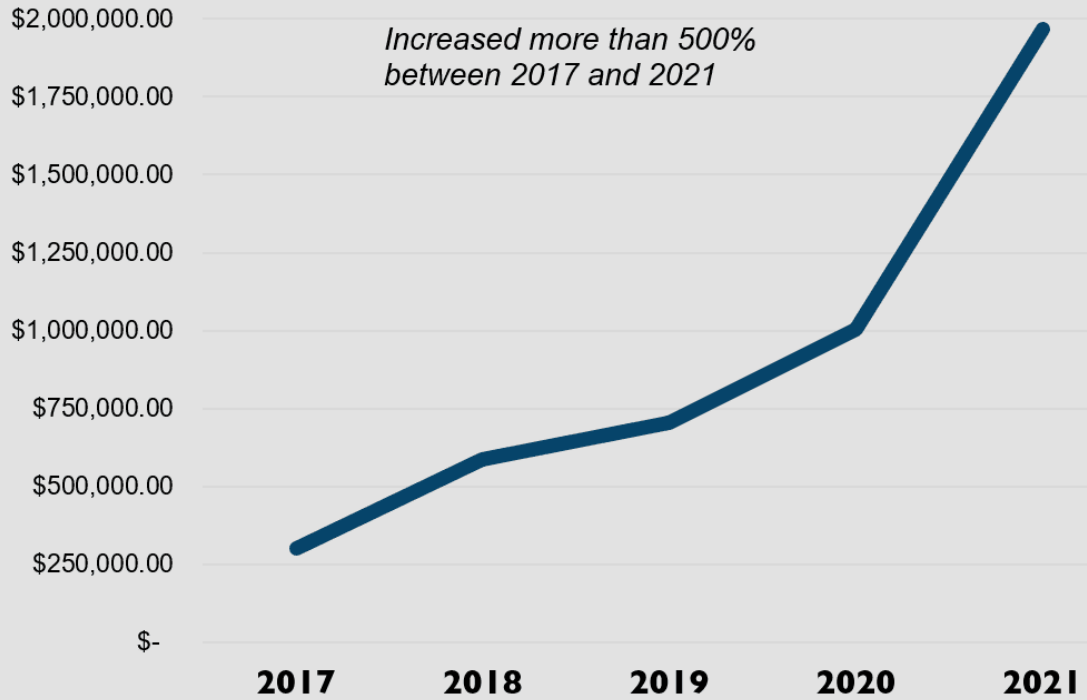

## Customers

### Our customers come in all freights and sizes

*QuickLoadz Intermodal Robotics benefits everyone in the supply chain.*

QuickLoadz shipped its first units in 2015. Since then, **tens of thousands of containers** have been delivered using every variety of our systems. Our QuickLoadz **design is customer-tested and approved, not just a concept.**



### **Some of our government customers:**

- US Army
- Idaho National Labs
- City of Everett, Washington

### **Some of our enterprise customers:**

- Britten Studios
- Irby Utilities
- Avista Utilities
- Ontario Public Power
- Middleby
- United Van Lines
- Pac-Van

### **Business Model**

## **Direct B2B sales of current models**

QuickLoadz Intermodal Robotics current models are a uniquely innovative and automated way to move sea shipping containers.

- The standard model is currently shipped with a 38 HP EFI engine (CARB compliant).
- By Q4 2021, QuickLoadz will offer as a no cost option an all electric unit.
- By Q4 2021 QuickLoadz will also offer other unique safety systems such as birds eye view 360 cameras on its trucks and trailers.



**2021**

**2022**

**2024**

**Direct sales of gasoline models**

Standard CARB-compliant 38 HP Kohler EFI engine

**Optional electric drivetrain**

E-motor replaces engine at no cost

**Lease-only  
Stealth model**

360° camera, Hybrid  
Power Axles and more

**Cloud Logistics  
Platform**

Leverages Brain Box on  
every QuickLoadz

## **The Stealth 40.**

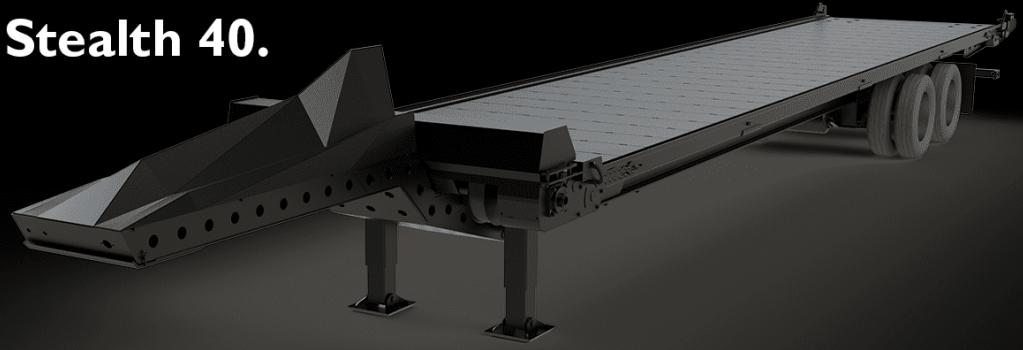

**New lease-only electric model.  
Est. 20% fuel savings and 900% return over trailer life.**

QuickLoadz is taking its all-electric unit to the next level.

The Stealth 40 will be all-electric with regenerative braking that charges as you drive down the highway. Hybrid Power Axles will also help push the truck as you accelerate. It's a trailer that turns your semi into a hybrid vehicle. Estimated 20% fuel savings are enough for the trailer to pay for itself.

This model will only be available as a lease. By leasing this unique product, QuickLoadz builds equity in its leasing pool while offering customers a superior new product at no risk.

**Subscription cloud-based logistics system**

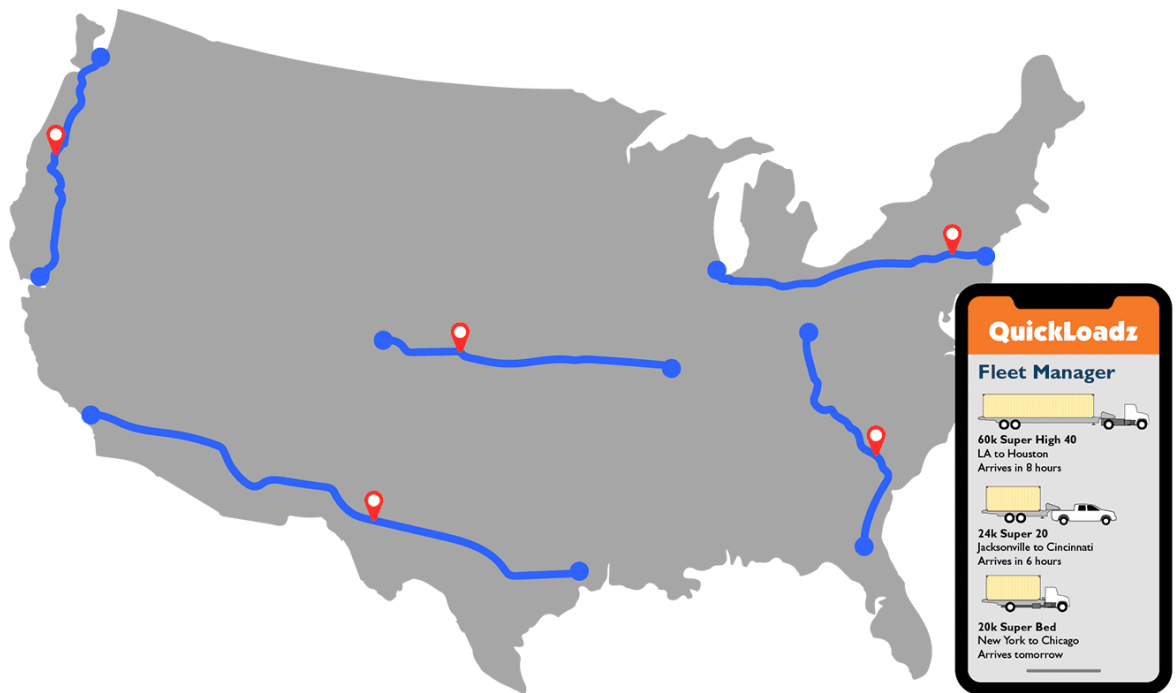

## The QuickLoadz Cloud Logistics Platform.

We're working on a catchier name.

- Every QuickLoadz has a computer with Wi-Fi, cellular and GPS
- With more software, we can create a cloud logistics platform
- Dispatchers can remotely check status of their fleet of QuickLoadz
- Where the trailer is, if the brakes hold air, if there's a flat tire, what its status is, where it dropped off its container, if there's an accident

### Market

## Transport and logistics is a \$9.6T market ripe for tech disruption

Companies like Tesla, Waymo, TuSimple and Aurora are spending billions of dollars on developing the self-driving truck. That's only half of the job: our aim is to **leverage the billions spent on autonomy and transport logistics**. With **our self-delivering load technology**, QuickLoadz does the rest.

**QuickLoadz completes container movement.**

## Help clear worldwide port congestion.

Ports are overwhelmed and are turning to automation to increase efficiencies. Quickly moving containers on the ground is the key.



## Leverage billions spent on automation.

Toyota, Volvo and OutRider are pouring billions into autonomous solutions for ports and distribution centers. QuickLoadz completes this automation.



## OutRider's solution for distribution centers.

QuickLoadz expands OutRider's solution to use sea shipping containers at ground level, trading the \$18,000 container and chassis for \$3,000 containers while expanding OutRider to ports.



Toyota and Volvo's systems require a crane





## to unload.

An automated platform only solves a small part of the problem.

Couple a QuickLoadz with their solutions, and suddenly, the entire port opens up.

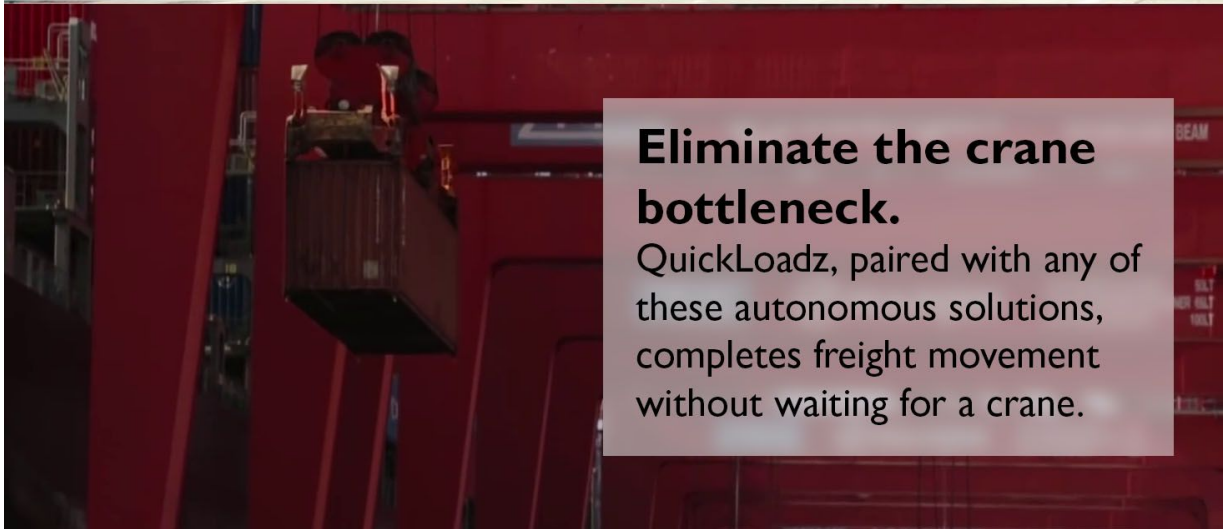

## Eliminate the crane bottleneck.

QuickLoadz, paired with any of these autonomous solutions, completes freight movement without waiting for a crane.

### Competition

## Blazing a new trail in the shipping world

Even though there are less expensive options to move empty containers, it still makes fiscal sense to purchase a QuickLoadz. Our system takes a difficult, dangerous 30 minute job using chains, winches and straps, and turns it into 3 minutes of pushing buttons on a smartphone.

### Costly alternatives



## Tow Trailer

- Only moves empty shipping containers
- Before moving, they must be emptied completely
- As you can imagine, that is extremely inconvenient
- Tow trailers have no way of pushing containers off the bed, so they must hang over the back of the trailer
- This is why they are only allowed to be transported empty



## Container Chassis

- Cannot load or unload container from itself without crane, forklift
- Container contents are trapped four feet in the air
- Can only unload at a loading dock and with expensive equipment
- Loading docks take hours to open up and hours to unload
- Chassis, truck and driver spend hundreds of hours a year waiting for their cargo to be handled instead of moving that cargo





- Also moves loaded containers without extra equipment
- Operator must control two heavy cranes on both sides simultaneously with the container precariously suspended by chains
- 2× the weight, 2× the price and 10× slower than QuickLoadz while requiring more training, maintenance and inspections regularly
- Not compatible with loading docks—there's a crane in the way

## **QuickLoadz**





**QuickLoadz**

- So automated, the driver never has to leave their seat in the truck
- Fully compatible with existing freight systems like loading docks
- Turns dangerous 30 minute job into 3 minutes of pushing buttons
- QuickLoadz customers move 2 extra containers a day
- Translates to \$100,000 extra income, four month ROI
- QuickLoadz owners see reduced driver turnover, saving thousands

QuickLoadz customers are able to do 2 more container moves a day with QuickLoadz. That translates to \$100,000 per year additional income from using a QuickLoadz over a winch trailer.

## Vision

# Creating the world's new freight and logistics platform

*Our mission is to **change the world of freight and logistics** by creating an automated way of moving sea shipping containers.*

The intermodal shipping container was invented in 1956. This simple idea of putting the merchandise in big steel boxes, instead of hand-carried on ships, entirely opened up world trade. By some estimates, the cost of international shipping dropped by 90%.

However, the handling of these containers hasn't significantly changed in 50 years. Containers still require giant cranes, loading docks and distribution centers to access their contents—until QuickLoadz Intermodal Robotics.



# QuickLoadz Intermodal Robotics

automates the movement of shipping containers and allows them to be moved from carrier to carrier in 3 minutes.



Not only does QuickLoadz streamline the movement of sea shipping containers for existing companies, QuickLoadz expands the use of intermodal freight to those that never have had access to it. Small businesses and emerging business empires can suddenly receive and ship freight just like large companies on the most efficient freight system ever devised, intermodal.

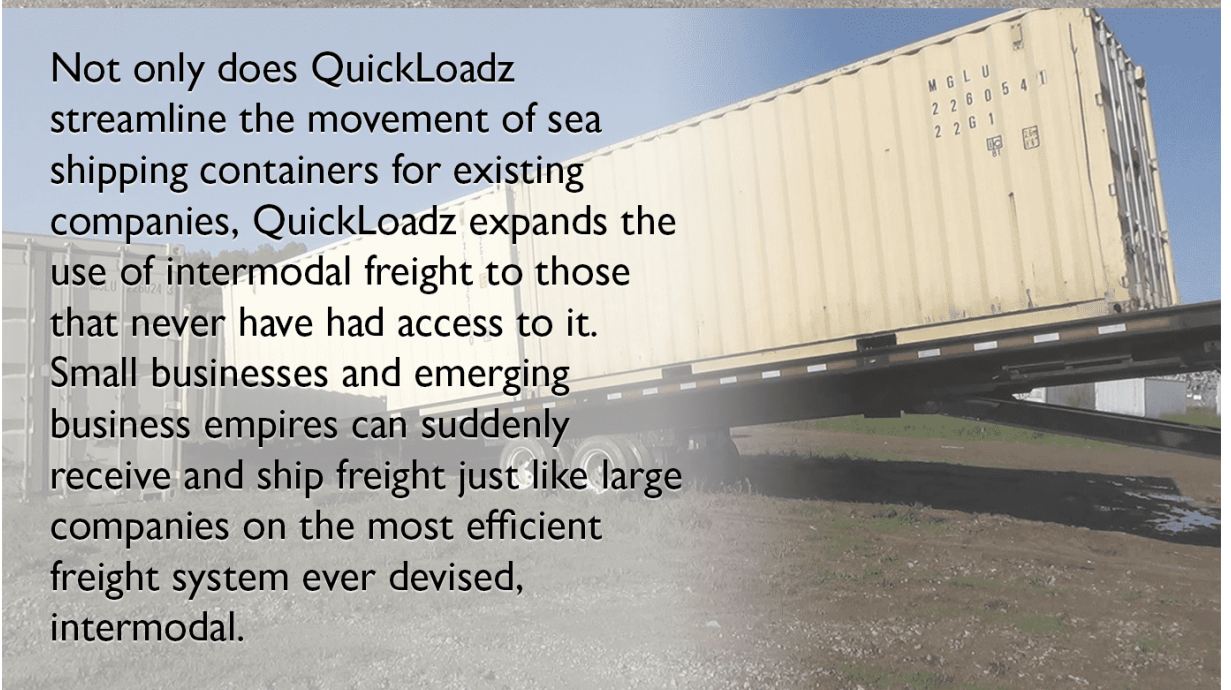

Pair any QuickLoadz with the self-driving truck and you have **end-to-end autonomous** movement of freight.

Add the Stealth 40, an all-electric trailer with Hybrid Power Axles, and you effectively turn **any semi** into a hybrid vehicle.



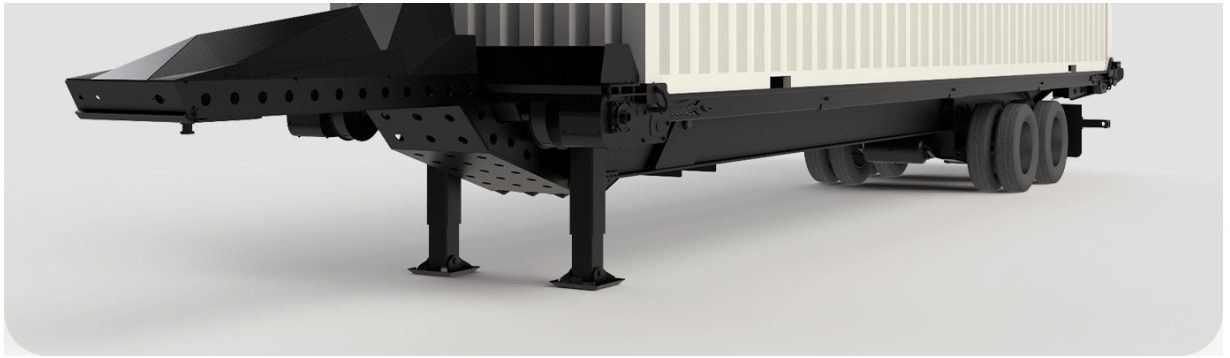

## Investors

### Raising to accelerate production and scale

QuickLoadz has been **entirely bootstrapped** until this raise.

QuickLoadz founders Sean Jones and Bridget Lair have invested \$2,793,386 in personal cash into QuickLoadz.

In addition, QuickLoadz has a \$2,850,000 loan, which it used to purchase and renovate its new 47,000 square foot facility.

QuickLoadz is raising money to scale production, add sales and marketing staff, and let the world know that there is now an easier way to move the 168,000,000 containers that are the basis of world trade.

## Founders

### Led by a serial entrepreneur with many successful exits



#### Sean Jones has a strong history of working on entrepreneurial ventures:

- *Swindlefish Saloon*—live music and dance bar
- *Rockside Rentals*—over a dozen profitable student rental housing assets renovated and sold
- *Rockside Storage*—mobile storage monopoly sold to national leader
- *Rockside Construction*—housing contractor work

#### Awards and Recognitions

- Electrical Engineering with Honors, Ohio University

- Awarded Stocker Fellowship from Ohio University
- Entrepreneur of the Year Award, TechGrowth Ohio

---

## Team



Sean  
Jones

Chief  
Executive  
Officer

Serial entrepreneur in construction, mobile storage with many successful exits.



Bridget  
Lair

Chief  
Financial  
Officer

Co-founder and data scientist, research analyst with Master's degree in global development.



Ash  
O'Brien

Director of  
Operations



Ben  
Vancouver

Production  
Manager



Phoenix  
Jones

V.P. of  
Engineering

---

## Perks

**\$1,000**

The QuickLoadz building brick toy. This 77-piece Lego™-compatible set is a replica of the 24k Super 20 trailer with Gooseneck Coupler. The fully constructed model has many of the features of the real model: a tilting bed, Lift Wedges and the Brain Box (non-functional).

---

## FAQ

**EXHIBIT C**

*Form of Security*



THIS INSTRUMENT HAS BEEN ISSUED PURSUANT TO SECTION 4(A)(6) OF THE SECURITIES ACT OF 1933, AS AMENDED (THE “**SECURITIES ACT**”), AND NEITHER IT NOR ANY SECURITIES ISSUABLE PURSUANT HERETO HAVE BEEN REGISTERED UNDER THE SECURITIES ACT OR THE SECURITIES LAWS OF ANY STATE. THESE SECURITIES MAY NOT BE OFFERED, SOLD OR OTHERWISE TRANSFERRED, PLEDGED OR HYPOTHECATED EXCEPT AS PERMITTED BY RULE 501 OF REGULATION CROWDFUNDING UNDER THE SECURITIES ACT AND APPLICABLE STATE SECURITIES LAWS OR PURSUANT TO AN EFFECTIVE REGISTRATION STATEMENT OR EXEMPTION THEREFROM.

IF THE INVESTOR LIVES OUTSIDE THE UNITED STATES, IT IS THE INVESTOR’S RESPONSIBILITY TO FULLY OBSERVE THE LAWS OF ANY RELEVANT TERRITORY OR JURISDICTION OUTSIDE THE UNITED STATES IN CONNECTION WITH ANY PURCHASE OF THE SECURITIES, INCLUDING OBTAINING REQUIRED GOVERNMENTAL OR OTHER CONSENTS OR OBSERVING ANY OTHER REQUIRED LEGAL OR OTHER FORMALITIES. THE COMPANY RESERVES THE RIGHT TO DENY THE PURCHASE OF THE SECURITIES BY ANY FOREIGN PURCHASER.

**QUICK LOADZ CONTAINER SYSTEM, LLC**

**Crowd SAFE  
(Crowdfunding Simple Agreement for Future Equity)**

**Series 2022**

THIS CERTIFIES THAT in exchange for the payment by [Investor Name] (the “Investor”, and together with all other Series 2022 Crowd SAFE holders, “Investors”) of \$[Purchase Amount] (the “Purchase Amount”) on or about [Date of Crowd SAFE], Quick Loadz Container System, LLC, an Ohio limited liability company (the “Company”), hereby issues to the Investor the right to certain interests of the Company’s Equity Interests (defined below), subject to the terms set forth below.

The “Valuation Cap” is \$12,000,000.

See Section 2 for certain additional defined terms.

**1. Events**

(a) **Equity Financing.**

(i) If an Equity Financing occurs before this instrument terminates in accordance with Sections 1(b)-(d) (“**First Equity Financing**”), the Company shall promptly notify the Investor of the closing of the First Equity Financing and of the Company’s discretionary decision to either (1) continue the term of this Crowd SAFE without converting the Purchase Amount to Equity Interests; or (2) issue to the Investor a number of the CF Shadow Series of the Equity Interests (whether Preferred Securities or another class issued by the Company), as applicable, sold in the First Equity Financing. The number of the CF Shadow Series of such Equity Interests shall equal the quotient obtained by dividing (x) the Purchase Amount by (y) the **First Equity Financing Price** (as defined below).

(ii) If the Company elects to continue the term of this Crowd SAFE past the First Equity Financing and another Equity Financing occurs before the termination of this Crowd SAFE in

accordance with Sections 1(b)-(d) (each, a “**Subsequent Equity Financing**”), the Company shall promptly notify the Investor of the closing of the Subsequent Equity Financing and of the Company’s discretionary decision to either (1) continue the term of this Crowd SAFE without converting the Investor’s Purchase Amount to Equity Interests; or (2) issue to the Investor a number of the CF Shadow Series of the Equity Interests (whether Preferred Securities or another class issued by the Company) sold in the Subsequent Equity Financing. The number of the CF Shadow Series of such Equity Interests shall equal to the quotient obtained by dividing (x) the Purchase Amount by (y) the First Equity Financing Price.

(b) **Liquidity Event.**

(i) If there is a Liquidity Event before the termination of this instrument and before any Equity Financing, the Investor must select, at its option, within thirty (30) days of receiving notice (whether actual or constructive), either (1) to receive a cash payment equal to the Purchase Amount (or a lesser amount as described below) or (2) to receive from the Company a number of Common Securities equal to the Purchase Amount (or a lesser amount as described below) divided by the Liquidity Price.

(ii) If there is a Liquidity Event after one or more Equity Financings have occurred but before the termination of this instrument, the Investor must select, at its option, within thirty (30) days of receiving notice (whether actual or constructive), either (1) to receive a cash payment equal to the Purchase Amount (or a lesser amount as described below) or (2) to receive from the Company a number of the most recent issued Equity Interests (whether Preferred Securities or another class issued by the Company) equal to the Purchase Amount divided by the First Equity Financing Price. Equity Interests granted in connection therewith shall have the same liquidation rights and preferences as the Equity Interests issued in connection with the Company’s most recent Equity Financing.

(iii) If there are not enough funds to pay the Investor and holders of other Crowd SAFEs (collectively, the “**Cash-Out Investors**”) in full, then all of the Company’s available funds will be distributed with equal priority and pro rata among the Cash-Out Investors in proportion to their Purchase Amounts. In connection with this Section 1(b), the Purchase Amount (or a lesser amount as described below) will be due and payable by the Company to the Investor immediately prior to, or concurrent with, the consummation of the Liquidity Event.

Notwithstanding Sections 1(b)(i)(2) or 1(b)(ii)(2), if the Company’s manager(s) (or board of directors if the Company becomes a corporation) determines in good faith that delivery of Equity Interests to the Investor pursuant to Section 1(b)(i)(2) or Section 1(b)(ii)(2) would violate applicable law, rule or regulation, then the Company shall deliver to Investor in lieu thereof, a cash payment equal to the fair market value of such Equity Interests, as determined in good faith by the Company’s manager(s) (or board of directors if the Company becomes a corporation).

(c) **Dissolution Event.** If there is a Dissolution Event before this instrument terminates in accordance with Sections 1(a) or 1(b), subject to the preferences applicable to any series of Preferred Securities, the Company will distribute its entire assets legally available for distribution with equal priority among the (i) Investors (on an as converted basis based on a valuation of Common Securities as determined in good faith by the Company’s manager(s) (or board of directors if the Company becomes a corporation) at the time of Dissolution Event), (ii) all other holders of instruments sharing in the assets of the Company at the same priority as holders of Common Securities upon a Dissolution Event and (iii) and all holders of Common Securities.

(d) **Termination.** This instrument will terminate (without relieving the Company or the Investor of any obligations arising from a prior breach of or non-compliance with this instrument) upon the earlier to occur: (i) the issuance of interests, whether in Equity Interests or in the CF Shadow Series or



Common Securities to the Investor pursuant to Section 1(a) or Section 1(b); or (ii) the payment, or setting aside for payment, of amounts due to the Investor pursuant to Sections 1(b) or 1(c).

## 2. *Definitions*

“**CF Shadow Series**” shall mean a non-voting series of Equity Interests that is otherwise identical in all respects to the Equity Interests (whether Preferred Securities or another class issued by the Company) issued in the relevant Equity Financing (e.g., if the Company sells Series A Preferred Securities in an Equity Financing, the Shadow Series would be Series A-CF Preferred Securities), except that:

- (i) CF Shadow Series members shall have no voting rights and shall not be entitled to vote on any matter that is submitted to a vote or for the consent of the members of the Company; and
- (ii) CF Shadow Series members have no information or inspection rights, except with respect to such rights deemed not waivable by laws.

“**Change of Control**” means (i) a transaction or series of related transactions in which any “person” or “group” (within the meaning of Sections 13(d) and 14(d) of the Securities Exchange Act of 1934, as amended), becomes the “beneficial owner” (as defined in Rule 13d-3 under the Securities Exchange Act of 1934, as amended (the “**Exchange Act**”)), directly or indirectly, of more than 50% of the outstanding voting securities of the Company having the right to vote for the election of members of the Company’s board of directors or manager(s), (ii) any reorganization, merger or consolidation of the Company, other than a transaction or series of related transactions in which the holders of the voting securities of the Company outstanding immediately prior to such transaction or series of related transactions retain, immediately after such transaction or series of related transactions, at least a majority of the total voting power represented by the outstanding voting securities of the Company or such other surviving or resulting entity or (iii) a sale, lease or other disposition of all or substantially all of the assets of the Company.

“**Common Securities**” means common limited liability company membership units or membership interests of the Company or common stock of the Company, if the Company is restructured as a corporation, including the securities issuable upon the conversion of this instrument pursuant to Section 1(a) or 1(b). For purposes of this Crowd SAFE, “common limited liability company membership units” refers to those interests in the Company that, as of the relevant event, would be last to receive a repayment of all capital contributions made in respect of such interests.

“**Dissolution Event**” means (i) a voluntary termination of operations, (ii) a general assignment for the benefit of the Company’s creditors, (iii) the commencement of a case (whether voluntary or involuntary) seeking relief under Title 11 of the United States Code (the “**Bankruptcy Code**”), or (iv) any other liquidation, dissolution or winding up of the Company (excluding a Liquidity Event), whether voluntary or involuntary.

“**Equity Financing**” shall mean the next sale (or series of related sales) by the Company of its Equity Interests to one or more third parties following the date of this instrument from which the Company receives gross proceeds of not less than \$1,000,000 cash or cash equivalent (excluding the conversion of any instruments convertible into or exercisable or exchangeable for Equity Interests, such as SAFEs or convertible promissory notes) with the principal purpose of raising capital.

“**Equity Interests**” shall mean Common Securities, Preferred Securities, any other capital or profits interest of the Company or any securities convertible into, exchangeable for or conferring the right to purchase (with or without additional consideration) Common Securities or Preferred Securities,

except in each case, (i) any security granted, issued and/or sold by the Company to any director, officer, employee, advisor or consultant of the Company in such capacity for the primary purpose of soliciting or retaining his, her or its services, (ii) any convertible promissory notes issued by the Company, and (iii) any SAFEs issued.

**“First Equity Financing Price”** shall mean (x) if the pre-money valuation of the Company immediately prior to the First Equity Financing is less than or equal to the Valuation Cap, the lowest price per share of the Equity Securities sold in the First Equity Financing or (y) if the pre-money valuation of the Company immediately prior to the First Equity Financing is greater than the Valuation Cap, the SAFE Price.

**“Fully Diluted Capitalization”** shall mean the aggregate number, as of immediately prior to the First Equity Financing, of issued and outstanding Equity Interests, assuming full conversion or exercise of all convertible and exercisable securities then outstanding, including convertible Preferred Securities and all outstanding vested or unvested options or warrants to purchase Equity Interests, but excluding (i) the issuance of all Equity Interests reserved and available for future issuance under any of the Company’s existing equity incentive plans, (ii) convertible promissory notes issued by the Company, (iii) any SAFEs, and (iv) any equity securities that are issuable upon conversion of any outstanding convertible promissory notes or SAFEs.

**“Intermediary”** means OpenDeal Portal LLC, a registered securities crowdfunding portal CRD#283874, or a qualified successor.

**“IPO”** means: (A) the completion of an underwritten initial public offering of Equity Interests by the Company pursuant to: (I) a final prospectus for which a receipt is issued by a securities commission of the United States or of a province of Canada, or (II) a registration statement which has been filed with the United States Securities and Exchange Commission and is declared effective to enable the sale of Equity Interests by the Company to the public, which in each case results in such equity securities being listed and posted for trading or quoted on a recognized exchange; (B) the Company’s initial listing of its Capital Stock (other than shares of Capital Stock not eligible for resale under Rule 144 under the Securities Act) on a national securities exchange by means of an effective registration statement on Form S-1 filed by the Company with the SEC that registers shares of existing capital stock of the Company for resale, as approved by the Company’s board of directors, where such listing shall not be deemed to be an underwritten offering and shall not involve any underwriting services; or (C) the completion of a reverse merger or take-over whereby an entity (I) whose securities are listed and posted for trading or quoted on a recognized exchange, or (II) is a reporting issuer in the United States or the equivalent in any foreign jurisdiction, acquires all of the issued and outstanding Equity Interests of the Company.

**“Liquidity Capitalization”** means the number, as of immediately prior to the Liquidity Event, of the Company’s Equity Interests (on an as-converted basis) outstanding, assuming exercise or conversion of all outstanding vested and unvested options, warrants and other convertible securities, but excluding: (i) Equity Interests reserved and available for future grant under any equity incentive or similar plan; (ii) any SAFEs; (iii) convertible promissory notes; and (iv) any equity securities that are issuable upon conversion of any outstanding convertible promissory notes or SAFEs.

**“Liquidity Event”** means a Change of Control or an IPO.

**“Liquidity Price”** means the price per unit equal to (x) the Valuation Cap divided by (y) the Liquidity Capitalization.

“**Lock-up Period**” means the period commencing on the date of the final prospectus relating to the Company’s IPO, and ending on the date specified by the Company and the managing underwriter(s). Such period shall not exceed one hundred eighty (180) days, or such other period as may be requested by the Company or an underwriter to accommodate regulatory restrictions on (i) the publication or other distribution of research reports, and (ii) analyst recommendations and opinions.

“**Preferred Securities**” means the preferred limited liability company membership units or membership interests of the Company or preferred stock of the Company, if the Company is restructured as a corporation.

“**Regulation CF**” means Regulation Crowdfunding promulgated under the Securities Act.

“**SAFE**” means any simple agreement for future equity (or other similar agreement), including a Crowd SAFE, which is issued by the Company for bona fide financing purposes and which may convert into Equity Interests in accordance with its terms.

“**SAFE Price**” means the price per unit equal to (x) the Valuation Cap divided by (y) the Fully Diluted Capitalization.

### **3. Company Representations**

(a) The Company is a limited liability company duly organized, validly existing and in good standing under the laws of the state of its organization, and has the power and authority to own, lease and operate its properties and carry on its business as now conducted.

(b) The execution, delivery and performance by the Company of this instrument is within the power of the Company and, other than with respect to the actions to be taken when equity is to be issued to the Investor, has been duly authorized by all necessary actions on the part of the Company. This instrument constitutes a legal, valid and binding obligation of the Company, enforceable against the Company in accordance with its terms, except as limited by bankruptcy, insolvency or other laws of general application relating to or affecting the enforcement of creditors’ rights generally and general principles of equity. To the knowledge of the Company, it is not in violation of (i) its current organizational documents; (ii) any material statute, rule or regulation applicable to the Company; or (iii) any material indenture or contract to which the Company is a party or by which it is bound, where, in each case, such violation or default, individually, or together with all such violations or defaults, could reasonably be expected to have a material adverse effect on the Company.

(c) The performance and consummation of the transactions contemplated by this instrument do not and will not: (i) violate any material judgment, statute, rule or regulation applicable to the Company; (ii) result in the acceleration of any material indenture or contract to which the Company is a party or by which it is bound; or (iii) result in the creation or imposition of any lien upon any property, asset or revenue of the Company or the suspension, forfeiture, or nonrenewal of any material permit, license or authorization applicable to the Company, its business or operations.

(d) No consents or approvals are required in connection with the performance of this instrument, other than: (i) approvals from the Company’s members or board of managers; (ii) any qualifications or filings under applicable securities laws; and (iii) necessary corporate approvals for the authorization of interests of CF Shadow Series issuable pursuant to Section 1.

(e) If the Company, prior to the conversion of this instrument, is restructured as a corporation, then it shall reserve from its authorized but unissued shares of Equity Interests for issuance and delivery

upon the conversion of this instrument, such number of shares of the Equity Interests as necessary to effect the conversion contemplated by this instrument, and, from time to time, will take all steps necessary to amend its charter to provide sufficient authorized numbers of shares of the Equity Interests issuable upon the conversion of this instrument. All such shares shall be duly authorized, and when issued upon any such conversion, shall be validly issued, fully paid and non-assessable, free and clear of all liens, security interests, charges and other encumbrances or restrictions on sale and free and clear of all preemptive rights, except encumbrances or restrictions arising under federal or state securities laws.

(f) The Company is (i) not required to file reports pursuant to Section 13 or Section 15(d) of the Exchange Act, (ii) not an investment company as defined in Section 3 of the Investment Company Act of 1940 (the “**Investment Company Act**”), and is not excluded from the definition of investment company by Section 3(b) or Section 3(c) of the Investment Company Act, (iii) not disqualified from selling securities under Rule 503(a) of Regulation CF, (iv) not barred from selling securities under Section 4(a)(6) of the Securities Act due to a failure to make timely annual report filings, (vi) not planning to engage in a merger or acquisition with an unidentified company or companies, and (vii) organized under, and subject to, the laws of a state or territory of the United States or the District of Columbia.

(g) The Company has, or will shortly after the issuance of this instrument, engage a transfer agent registered with the U.S. Securities and Exchange Commission to act as the sole registrar and transfer agent for the Company with respect to the Crowd SAFE.

#### **4. *Investor Representations***

(a) The Investor has full legal capacity, power and authority to execute and deliver this instrument and to perform its obligations hereunder. This instrument constitutes a valid and binding obligation of the Investor, enforceable in accordance with its terms, except as limited by bankruptcy, insolvency or other laws of general application relating to or affecting the enforcement of creditors’ rights generally and general principles of equity.

(b) The Investor has been advised that this instrument and the underlying securities have not been registered under the Securities Act or any state securities laws and are offered and sold hereby pursuant to Section 4(a)(6) of the Securities Act. The Investor understands that neither this instrument nor the underlying securities may be resold or otherwise transferred unless they are registered under the Securities Act and applicable state securities laws or pursuant to Rule 501 of Regulation CF, in which case certain state transfer restrictions may apply.

(c) The Investor is purchasing this instrument and the securities to be acquired by the Investor hereunder for its own account for investment, not as a nominee or agent, and not with a view to, or for resale in connection with, the distribution thereof, and the Investor has no present intention of selling, granting any participation in, or otherwise distributing the same. The Investor understands that the Securities have not been, and will not be, registered under the Securities Act or any state securities laws, by reason of specific exemptions under the provisions thereof which depend upon, among other things, the bona fide nature of the investment intent and the accuracy of each Investor’s representations as expressed herein.

(d) The Investor acknowledges, and is purchasing this instrument in compliance with, the investment limitations set forth in Rule 100(a)(2) of Regulation CF, promulgated under Section 4(a)(6)(B) of the Securities Act.

(e) The Investor acknowledges that the Investor has received all the information the Investor has requested from the Company and the Investor considers necessary or appropriate for deciding whether

to acquire this instrument and the underlying securities, and the Investor represents that the Investor has had an opportunity to ask questions and receive answers from the Company regarding the terms and conditions of this instrument and the underlying securities and to obtain any additional information necessary to verify the accuracy of the information given to the Investor. In deciding to purchase this instrument, the Investor is not relying on the advice or recommendations of the Company or of the Intermediary and the Investor has made its own independent decision that an investment in this instrument and the underlying securities is suitable and appropriate for the Investor. The Investor understands that no federal or state agency has passed upon the merits or risks of an investment in this instrument and the underlying securities or made any finding or determination concerning the fairness or advisability of this investment.

(f) The Investor understands and acknowledges that as a Crowd SAFE investor, the Investor shall have no voting, information or inspection rights, aside from any disclosure requirements the Company is required to make under relevant securities regulations.

(g) The Investor understands that no public market now exists for any of the securities issued by the Company, and that the Company has made no assurances that a public market will ever exist for this instrument and the securities to be acquired by the Investor hereunder.

(h) The Investor is not (i) a citizen or resident of a geographic area in which the purchase or holding of the Crowd SAFE and the underlying securities is prohibited by applicable law, decree, regulation, treaty, or administrative act, (ii) a citizen or resident of, or located in, a geographic area that is subject to U.S. or other applicable sanctions or embargoes, or (iii) an individual, or an individual employed by or associated with an entity, identified on the U.S. Department of Commerce's Denied Persons or Entity List, the U.S. Department of Treasury's Specially Designated Nationals List, the U.S. Department of State's Debarred Parties List or other applicable sanctions lists. Investor hereby represents and agrees that if Investor's country of residence or other circumstances change such that the above representations are no longer accurate, Investor will immediately notify Company. Investor further represents and warrants that it will not knowingly sell or otherwise transfer any interest in the Crowd SAFE or the underlying securities to a party subject to U.S. or other applicable sanctions.

(i) If the Investor is not a United States person (as defined by Section 7701(a)(30) of the Internal Revenue Code of 1986, as amended), the Investor hereby represents that it has satisfied itself as to the full observance of the laws of its jurisdiction in connection with any invitation, subscription and payment for, and continued ownership of, its beneficial interest in the Crowd SAFE and the underlying securities will not violate any applicable securities or other laws of the Investor's jurisdiction, including (i) the legal requirements within its jurisdiction for the subscription and the purchase of its beneficial interest in the Crowd SAFE; (ii) any foreign exchange restrictions applicable to such subscription and purchase; (iii) any governmental or other consents that may need to be obtained; and (iv) the income tax and other tax consequences, if any, that may be relevant to the purchase, holding, conversion, redemption, sale, or transfer of its beneficial interest in the Crowd SAFE and the underlying securities. The Investor acknowledges that the Company has taken no action in foreign jurisdictions with respect to the Crowd SAFE (and the Investor's beneficial interest therein) and the underlying securities.

(j) If the Investor is a corporate entity: (i) such corporate entity is duly incorporated, validly existing and in good standing under the laws of the state of its incorporation, and has the power and authority to enter into this Crowd SAFE; (ii) the execution, delivery and performance by the Investor of this Crowd SAFE is within the power of the Investor and has been duly authorized by all necessary actions on the part of the Investor; (iii) to the knowledge of the Investor, it is not in violation of its current organizational documents, any material statute, rule or regulation applicable to the Investor; and (iv) the performance of this Crowd SAFE does not and will not violate any material judgment, statute, rule or regulation applicable

to the Investor; result in the acceleration of any material indenture or contract to which the Investor is a party or by which it is bound, or otherwise result in the creation or imposition of any lien upon the Purchase Amount.

(k) The Investor further acknowledges that it has read, understood, and had ample opportunity to ask Company questions about its business plans, “Risk Factors,” and all other information presented in the Company’s Form C and the offering documentation filed with the SEC.

(l) The Investor represents that the Investor understands the substantial likelihood that the Investor will suffer a **TOTAL LOSS** of all capital invested, and that Investor is prepared to bear the risk of such total loss.

## ***5. Transfer Restrictions.***

(a) The Investor hereby agrees that during the Lock-up Period it will not, without the prior written consent of the managing underwriter: (A) lend; offer; pledge; sell; contract to sell; sell any option or contract to purchase; purchase any option or contract to sell; grant any option, right, or warrant to purchase; or otherwise transfer or dispose of, directly or indirectly, any Equity Interests or any securities convertible into or exercisable or exchangeable (directly or indirectly) for Equity Interests (whether such interests or any such securities are then owned by the Investor or are thereafter acquired); or (B) enter into any swap or other arrangement that transfers to another, in whole or in part, any of the economic consequences of ownership of such securities; whether any such transaction described in clause (A) or (B) above is to be settled by delivery of Equity Interests or other securities, in cash, or otherwise.

(b) The foregoing provisions of Section 5(a) will: (x) apply only to the IPO and will not apply to the sale of any of the Company’s securities issued to an underwriter pursuant to an underwriting agreement; (y) not apply to the transfer of any Company’s securities to any trust for the direct or indirect benefit of the Investor or the immediate family of the Investor, provided that the trustee of the trust agrees to be bound in writing by the restrictions set forth herein, and provided further that any such transfer will not involve a disposition for value; and (z) be applicable to the Investor only if all managers, officers and directors of the Company are subject to the same restrictions and the Company uses commercially reasonable efforts to obtain a similar agreement from all members individually owning more than 5% of the outstanding Common Securities or any securities convertible into or exercisable or exchangeable (directly or indirectly) for Common Securities. Notwithstanding anything herein to the contrary, the underwriters in connection with the IPO are intended third-party beneficiaries of Section 5(a) and will have the right, power and authority to enforce the provisions hereof as though they were a party hereto. The Investor further agrees to execute such agreements as may be reasonably requested by the underwriters in connection with the IPO that are consistent with Section 5(a) or that are necessary to give further effect thereto.

(c) In order to enforce the foregoing covenant, the Company may impose stop transfer instructions with respect to the Investor’s registrable securities of the Company (and the Company securities or securities of every other person subject to the foregoing restriction) until the end of the Lock-up Period. The Investor agrees that a legend reading substantially as follows will be placed on all certificates representing all of the Investor’s registrable securities of the Company (and the securities of the Company held by every other person subject to the restriction contained in Section 5(a)):

THE SECURITIES REPRESENTED BY THIS CERTIFICATE ARE SUBJECT TO A LOCK-UP PERIOD BEGINNING ON THE EFFECTIVE DATE OF THE COMPANY’S REGISTRATION STATEMENT FILED UNDER THE SECURITIES ACT OF 1933, AS AMENDED, AS SET FORTH IN AN AGREEMENT BETWEEN THE COMPANY

AND THE ORIGINAL HOLDER OF THESE SECURITIES, A COPY OF WHICH MAY BE OBTAINED AT THE COMPANY'S PRINCIPAL OFFICE. SUCH LOCK-UP PERIOD IS BINDING ON TRANSFEREES OF THESE SECURITIES.

(d) Without in any way limiting the representations and warranties set forth in Section 4 above, the Investor further agrees not to make any disposition of all or any portion of this instrument or the underlying securities unless and until the transferee has agreed in writing for the benefit of the Company to make the representations and warranties set out in Section 4 and the undertaking set out in Section 5(a) and:

(i) There is then in effect a registration statement under the Securities Act covering such proposed disposition and such disposition is made in accordance with such registration statement; or

(ii) The Investor shall have notified the Company of the proposed disposition and shall have furnished the Company with a detailed statement of the circumstances surrounding the proposed disposition and, if reasonably requested by the Company, the Investor shall have furnished the Company with an opinion of counsel reasonably satisfactory to the Company that such disposition will not require registration of such securities under the Securities Act.

(e) The Investor agrees that it shall not make any disposition of this instrument or any underlying securities to any of the Company's competitors, as determined by the Company in good faith.

(f) The Investor understands and agrees that the Company will place the legend set forth below or a similar legend on any book entry or other forms of notation evidencing this Crowd SAFE and any certificates evidencing the underlying securities, together with any other legends that may be required by state or federal securities laws, the Company's organizational documents, any other agreement between the Investor and the Company or any agreement between the Investor and any third party:

THIS INSTRUMENT HAS BEEN ISSUED PURSUANT TO SECTION 4(A)(6) OF THE SECURITIES ACT OF 1933, AS AMENDED (THE "SECURITIES ACT"), AND NEITHER IT NOR ANY SECURITIES ISSUABLE PURSUANT HERETO HAVE BEEN REGISTERED UNDER THE SECURITIES ACT OR THE SECURITIES LAWS OF ANY STATE. THESE SECURITIES MAY NOT BE OFFERED, SOLD OR OTHERWISE TRANSFERRED, PLEDGED OR HYPOTHECATED EXCEPT AS PERMITTED BY RULE 501 OF REGULATION CROWDFUNDING UNDER THE SECURITIES ACT AND APPLICABLE STATE SECURITIES LAWS OR PURSUANT TO AN EFFECTIVE REGISTRATION STATEMENT OR EXEMPTION THEREFROM.

## **6. *Miscellaneous***

(a) The Investor agrees to execute the Nominee Rider and Waiver, attached hereto as Exhibit A contemporaneously and in connection with the purchase of this Crowd SAFE.

(b) The Investor agrees to take any and all actions determined in good faith by the Company's board of managers or equivalent governance body to be advisable to reorganize this instrument and any Equity Interests issued pursuant to the terms of this instrument into a special purpose vehicle or other entity designed to aggregate the interests of holders of Crowd SAFEs.

(c) Any provision of this instrument may be amended, waived or modified only upon the written consent of either (i) the Company and the Investor, or (ii) the Company and the majority of the Investors (calculated based on the Purchase Amount of each Investors Crowd SAFE).

(d) Any notice required or permitted by this instrument will be deemed sufficient when delivered personally or by overnight courier or sent by email to the relevant address listed on the signature page, or 48 hours after being deposited in the U.S. mail as certified or registered mail with postage prepaid, addressed to the party to be notified at such party's address listed on the signature page, as subsequently modified by written notice.

(e) The Investor is not entitled, as a holder of this instrument, to vote or receive dividends or be deemed the holder of Equity Interests for any purpose, nor will anything contained herein be construed to confer on the Investor, as such, any of the rights of a member of the Company or any right to vote for the election of directors/manager(s) or upon any matter submitted to member at any meeting thereof, or to give or withhold consent to any corporate action or to receive notice of meetings, or to receive subscription rights or otherwise until interests have been issued upon the terms described herein.

(f) Neither this instrument nor the rights contained herein may be assigned, by operation of law or otherwise, by either party without the prior written consent of the other; *provided, however*, that this instrument and/or the rights contained herein may be assigned without the Company's consent by the Investor to any other entity who directly or indirectly, controls, is controlled by or is under common control with the Investor, including, without limitation, any general partner, managing member, officer or director of the Investor, or any venture capital fund now or hereafter existing which is controlled by one or more general partners or managing members of, or units in the same management company with, the Investor; and *provided, further*, that the Company may assign this instrument in whole, without the consent of the Investor, in connection with a reincorporation to change the Company's domicile or organizational form.

(g) In the event any one or more of the terms or provisions of this instrument is for any reason held to be invalid, illegal or unenforceable, in whole or in part or in any respect, or in the event that any one or more of the terms or provisions of this instrument operate or would prospectively operate to invalidate this instrument, then such term(s) or provision(s) only will be deemed null and void and will not affect any other term or provision of this instrument and the remaining terms and provisions of this instrument will remain operative and in full force and effect and will not be affected, prejudiced, or disturbed thereby.

(h) All securities issued under this instrument may be issued in whole or fractional parts, in the Company's sole discretion.

(i) All rights and obligations hereunder will be governed by the laws of the State of Ohio, without regard to the conflicts of law provisions of such jurisdiction.

(j) Any dispute, controversy or claim arising out of, relating to or in connection with this instrument, including the breach or validity thereof, shall be determined by final and binding arbitration administered by the American Arbitration Association (the "AAA") under its Commercial Arbitration Rules and Mediation Procedures ("**Commercial Rules**"). The award rendered by the arbitrator shall be final, non-appealable and binding on the parties and may be entered and enforced in any court having jurisdiction. There shall be one arbitrator agreed to by the parties within twenty (20) days of receipt by respondent of the request for arbitration or, in default thereof, appointed by the AAA in accordance with its Commercial Rules. The place of arbitration shall be Columbus, Ohio. Except as may be required by law or to protect a legal right, neither a party nor the arbitrator may disclose the existence, content or results of any arbitration without the prior written consent of the other parties.



(k) The parties acknowledge and agree that for United States federal and state income tax purposes this Crowd SAFE is, and at all times has been, intended to be characterized as stock, and more particularly as common stock for purposes of Sections 304, 305, 306, 354, 368, 1036 and 1202 of the Internal Revenue Code of 1986, as amended. Accordingly, the parties agree to treat this Crowd SAFE consistent with the foregoing intent for all United States federal and state income tax purposes (including, without limitation, on their respective tax returns or other informational statements).

(l) The Investor agrees any action contemplated by this Crowd SAFE and requested by the Company must be completed by the Investor within thirty (30) calendar days of receipt of the relevant notice (whether actual or constructive) to the Investor.

*(Signature page follows)*

IN WITNESS WHEREOF, the undersigned have caused this instrument to be duly executed and delivered.

**QUICK LOADZ CONTAINER SYSTEM, LLC**

By:

Name: Sean Jones

Title: Chief Executive Officer

Address: 5850 Industrial Drive, Athens, Ohio 45780

Email: sjones@quickloadz.com

**INVESTOR:**

By:

Name:

**Exhibit A – Nominee Rider and Waiver**

**Nominee Rider and Waiver**

Republic Investment Services LLC (f/k/a NextSeed Services, LLC) (the “**Nominee**”) is hereby appointed to act on behalf of the Investor as agent and proxy in all respects under the Crowd SAFE Series 2022 issued by Quick Loadz Container System, LLC (the “**Security**”), to receive all notices and communications on behalf of the Investor, cause the Security or any securities which may be acquired upon conversion thereof (the “**Conversion Securities**”) to be custodied with a qualified custodian, and, to the extent the Securities or Conversion Securities are entitled to vote at any meeting or take action by consent, Nominee is authorized and empowered to vote and act on behalf of Investor in all respects thereto until the expiry of the Term (as defined below) (collectively the “**Nominee Services**”). Defined terms used in this Nominee Rider are controlled by the Security unless otherwise defined.

Nominee shall vote all such Securities and Conversion Securities consistently at the direction of the Chief Executive Officer of Quick Loadz Container System, LLC. Neither Nominee nor any of its affiliates nor any of their respective officers, partners, equity holders, managers, officers, directors, employees, agents or representatives shall be liable to Investor for any action taken or omitted to be taken by it hereunder, or in connection herewith or therewith, except for damages caused by its or their own recklessness or willful misconduct.

Upon any conversion of the Securities into Conversion Securities of the Company, in accordance with the terms of the Securities, Nominee will execute and deliver to the Issuer all transaction documents related to such transaction or other corporate event causing the conversion of the Securities in accordance therewith; *provided*, that such transaction documents are the same documents to be entered into by all holders of other Securities of the same class issued by the Company that will convert in connection with the equity financing or corporate event and being the same as the purchasers in the equity financing or corporate transaction. The Investor acknowledges and agrees, as part of the process, the Nominee may open an account in the name of the Investor with a qualified custodian and allow the qualified custodian to take custody of the Conversion Securities in exchange for a corresponding beneficial interest held by the Investor. Upon any such conversion or changing of title, Nominee will take reasonable steps to send notice to the Investor, using the last known contact information of such Investor.

The “**Term**” the Nominee Services will be provided will be the earlier of the time which the Securities or any Conversion Securities are (i) terminated, (ii) registered under the Exchange Act, or (iii) the time which the Nominee, the Investor and the Company mutually agree to terminate the Nominee Services.

To the extent you provide the Issuer with any personally identifiable information in connection with your election to invest in the Securities, the Issuer and its affiliates may share such information with the Nominee, the Intermediary, and the appointed transfer agent for the Securities solely for the purposes of facilitating the offering of the Securities and for each party to provide services with respect to the ownership and administration of the Securities. Investor irrevocably consents to such uses of Investor’s personally identifiable information for these purposes during the Term and Investor acknowledges that the use of such personally identifiable information is necessary for the Nominee to provide the Nominee Services.

*(Remainder of Page Intentionally Blank – Signature Page to Follow)*

IN WITNESS WHEREOF, the undersigned have caused this instrument to be duly executed and delivered.

**INVESTOR:**

By:  
Name:  
Date:

**NOMINEE:**

**Republic Investment Services LLC**

By:  
Name: Youngro Lee, CEO  
Date:

**COMPANY:**

By:  
Name:  
Date:

**EXHIBIT D**

*Video Transcript*

What's QuickLoadz?

QuickLoadz is a revolutionary automated trailer that is computer controlled and Wi-Fi enabled to allow a driver to move loaded shipping containers in three minutes without ever leaving their seat in the truck cab.

90% of the world's freight travels in standardized sea shipping containers. This is called intermodal freight and it is the basis for world trade. A \$9.6 trillion dollar market. Imagine that 90% of everything everyone buys travels in these sea shipping containers. Now imagine that one company in the world has figured out a way to make moving these containers from one place to another fast, safe and easy without any additional equipment.

QuickLoadz opens up the world to intermodal freight in a way never before possible. QuickLoadz allows any container to be moved anywhere without need for additional infrastructure such as loading docks, warehouses and cranes. Farmers can eliminate grain trailers, grain elevators and go straight from field to international shipping. Every small manufacturer or retail store can suddenly have dynamic 1/10-cost containerized warehouses—warehouses that they can ship all over the world. In emergency situations, relief supplies and containerized hospitals can be deployed rapidly, bringing the supplies and dropping them at ground level where needed. Parking lots become distribution centers. Massive infrastructure for trans-loading and storage are no longer needed. Logistics takes a giant leap forward in cost reduction and efficiency.

QuickLoadz is the last piece to create the new world of freight. A world where distribution centers can “pop-up,” expand, or contract where needed. A world where the autonomous truck can work with a QuickLoadz to deliver entire container loads of freight in 3 minutes without anyone touching the load.

QuickLoadz is all alone in this chance to revolutionize a 9.6 trillion dollar logistics market. QuickLoadz has no competition, has worldwide patents and is looking for partners to accelerate. QuickLoadz is cash flow positive and its customers include the US Army, Pac-Van, United Van Lines, and more.

QuickLoadz will change the world of freight and logistics in ways still not thought of. That's QuickLoadz. Want to come along?

**EXHIBIT E**

*Testing the Waters Communications*

**Company Name** QuickLoadz

**Logo**



**Headline** Smartphone-controlled robotic trailers for faster, safer, easier shipping

**Hero Image**



**Tags**

**Pitch text**

### Summary

- Potential to open the bottleneck for 90% of the worlds freight
- Total addressable market of \$9.6T+
- Solves final-mile distribution problems faced by companies like Amazon
- Computer controlled, Wi-Fi enabled system automates container movement
- Aiming to save large freight end-users billions of dollars annually
- All-electric product with Hybrid Power Axle system coming soon



## Problem

# Inefficient freight transport increases costs and drags on the global economy

**90% of the world's freight** travels in over 150,000,000 sea shipping containers. This merchandise can only be loaded or unloaded at loading docks and handled with expensive equipment at special facilities. This bottlenecks freight and logistics worldwide and chokes the world economy.



## Solution

# An automated way to move sea shipping containers

*without any additional equipment*

**QuickLoadz Intermodal Robotics smartphone-controlled trailers** are built to move the world's **168,000,000 ISO containers** faster, safer, and easier than ever before—expanding freight and **greatly improving efficiencies**.

Our hardware consists of a Wi-Fi-enabled, **computer-controlled trailer** that the driver operates from their smartphone. A driver can **load or unload 60,000 lbs.** of merchandise in **3 minutes** without ever leaving their seat in the truck cab.



**Controlled with the driver's smartphone.**

**Lift Wedges raise the container over the bed.**

**Built-in chains hook into the container corners.**

**The bed is pulled underneath the container.**

**Hydraulic locks slide into the container corners instantly.**

**Loading takes just three minutes with no manual labor.**

This Wi-Fi-controlled trailer lends itself to easy coupling with any driver in any truck. It makes easy control of the system for Autonomous Trucks such as TuSimple, Waymo, Plus, Kodiak, Tesla, or Embark.

## Everyone's excited about the self-driving truck.



T E S L A +

**QuickLoadz**



WAYMO



LOCOMOTION

**But the trailer is what makes the magic happen in shipping.**

By pairing these innovations together, QuickLoadz can turn shipping upside down.

### Product

## Truck beds and trailers that automate the movement of shipping containers

The QuickLoadz system consists of a patented mechanical system that uses the structure of any standard ISO sea shipping container to load/unload:



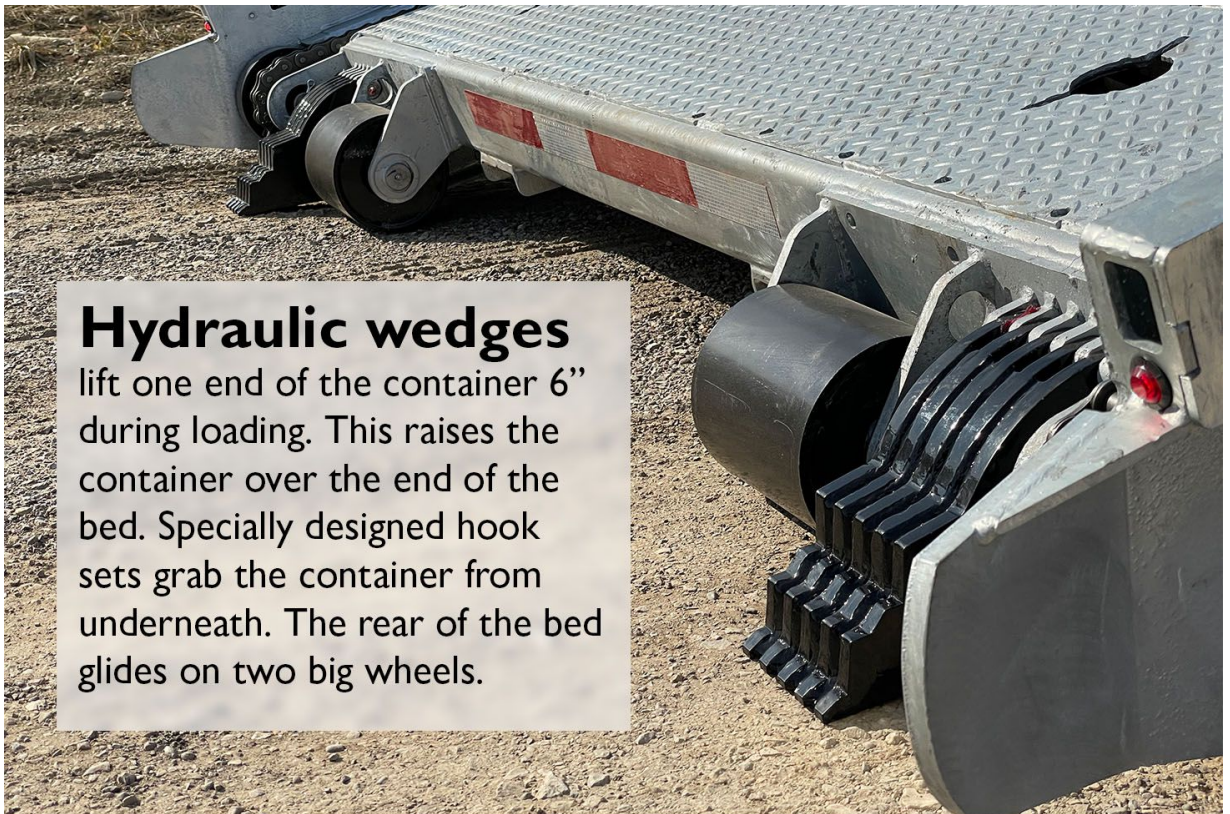

## Hydraulic wedges

lift one end of the container 6" during loading. This raises the container over the end of the bed. Specially designed hook sets grab the container from underneath. The rear of the bed glides on two big wheels.



## Both hooks

pull the bed under the stationary container. The container is pulled all the way to the front of the bed, and locked on with hydraulically-actuated pins.



## The bed tilts

back down and is ready to go in three minutes or less. This deceptively simple mechanism is the result of years of research and development.





This mechanism contains sophisticated mechanical processes to make the whole system work smoothly, a large part of our “secret sauce.”

The hardware portions of the system are patent-protected in countries all over the world, providing a deep moat against newcomers.

## The Brain Box

consists of a computer, Wi-Fi network and HD video processors for the available 6 camera inputs. The QuickLoadz Brain Box is also equipped to add GPS (location), GSM (cellular communications) and has room for future blank add-on boards.



This Brain Box controls a very sophisticated hydraulic control block that allows software control of both pressure and flow of hydraulics. In this way, units are universal between QuickLoadz models with different parameters set in the software. This system will also allow future “push and pull” of updates, locations and data much like Tesla.

# QuickLoadz Intermodal Robotics beds

are designed for mass manufacture. Across 10 different models ranging from 16,000 to 60,000 pound GVWR and 20' to 40' in length, the patented QuickLoadz hardware is standardized. Therefore, beds can be manufactured in mass and quickly assembled onto the frames needed for current orders.

In this way, QuickLoadz moves away from the need to stock finished trailers and can quickly build to order.



**The 24k Super 20**  
20' trailer for pickup trucks



**The 26k Super 40**  
40' trailer for pickup trucks



**The 40k Super Bed**  
Bed mounted on medium truck



**The 60k Super High 40**  
Trailer for big freight

## Traction

### QuickLoadz has been in hands of customers since 2015

*Thousands of containers moved, millions of miles traveled. Field testing is done. **Time to scale.***

- Current billion dollar enterprise-level customers.
- Multiple multi-unit orders.
- Sales usually doubling every year. Even in 2020, sales went up 43%.
- Development agreements with cutting-edge companies solving the world's last-mile delivery problems, such as Vaqari.
- Development agreement with self contained tiny home manufacturer Piedmont Green.
- Winner of awards from TechGrowth Ohio to Beijing, China.
- QuickLoadz units are trusted from Northern Canada to the United Arab Emirates.

# Sales

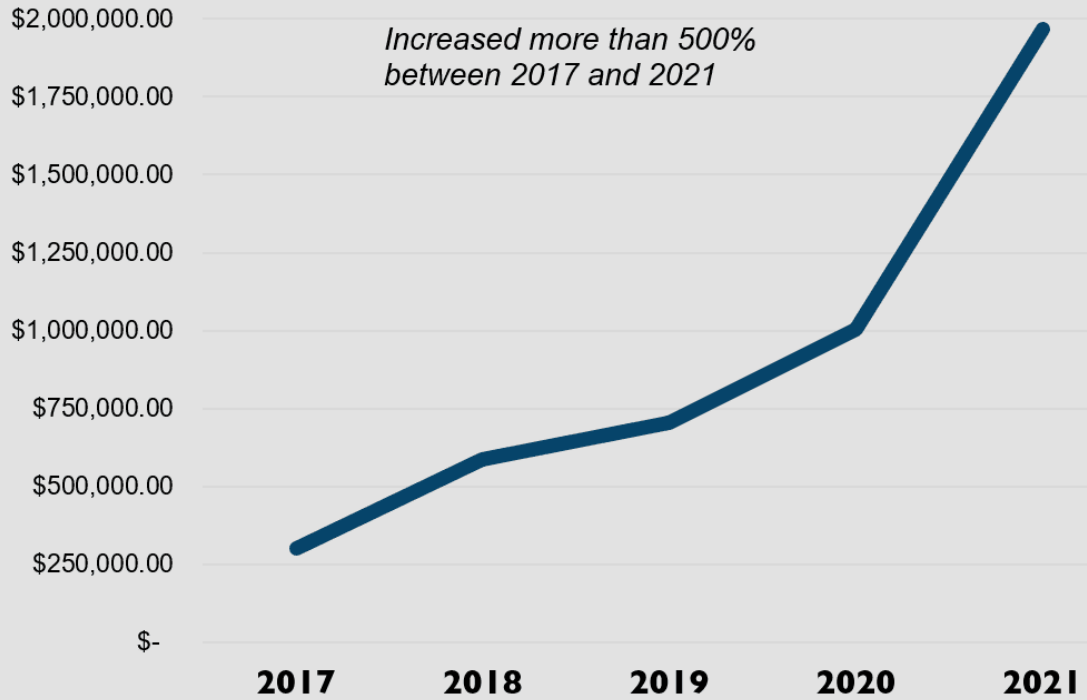

## Customers

### Our customers come in all freights and sizes

*QuickLoadz Intermodal Robotics benefits everyone in the supply chain.*

QuickLoadz shipped its first units in 2015. Since then, **tens of thousands of containers** have been delivered using every variety of our systems. Our QuickLoadz **design is customer-tested and approved, not just a concept.**



### **Some of our government customers:**

- US Army
- Idaho National Labs
- City of Everett, Washington

### **Some of our enterprise customers:**

- Britten Studios
- Irby Utilities
- Avista Utilities
- Ontario Public Power
- Middleby
- United Van Lines
- Pac-Van

### **Business Model**

## **Direct B2B sales of current models**

QuickLoadz Intermodal Robotics current models are a uniquely innovative and automated way to move sea shipping containers.

- The standard model is currently shipped with a 38 HP EFI engine (CARB compliant).
- By Q4 2021, QuickLoadz will offer as a no cost option an all electric unit.
- By Q4 2021 QuickLoadz will also offer other unique safety systems such as birds eye view 360 cameras on its trucks and trailers.

**2021**

**2022**

**2024**

**Direct sales of gasoline models**

Standard CARB-compliant 38 HP Kohler EFI engine

**Optional electric drivetrain**

E-motor replaces engine at no cost

**Lease-only  
Stealth model**

360° camera, Hybrid  
Power Axles and more

**Cloud Logistics  
Platform**

Leverages Brain Box on  
every QuickLoadz



## **The Stealth 40.**

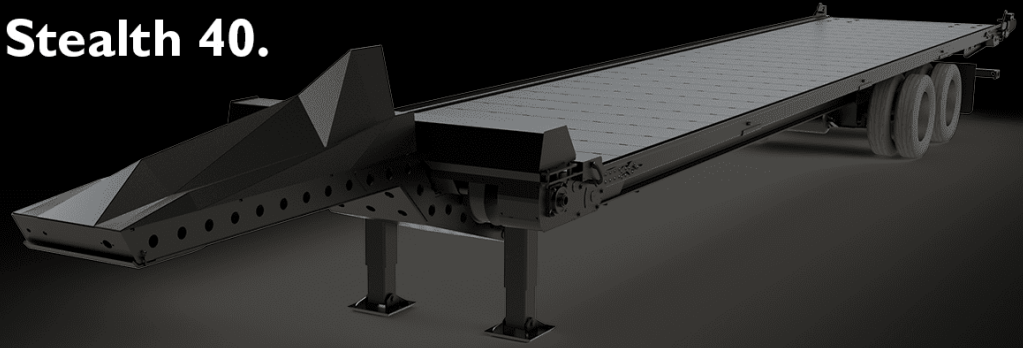

**New lease-only electric model.  
Est. 20% fuel savings and 900% return over trailer life.**

QuickLoadz is taking its all-electric unit to the next level.

The Stealth 40 will be all-electric with regenerative braking that charges as you drive down the highway. Hybrid Power Axles will also help push the truck as you accelerate. It's a trailer that turns your semi into a hybrid vehicle. Estimated 20% fuel savings are enough for the trailer to pay for itself.

This model will only be available as a lease. By leasing this unique product, QuickLoadz builds equity in its leasing pool while offering customers a superior new product at no risk.

**Subscription cloud-based logistics system**

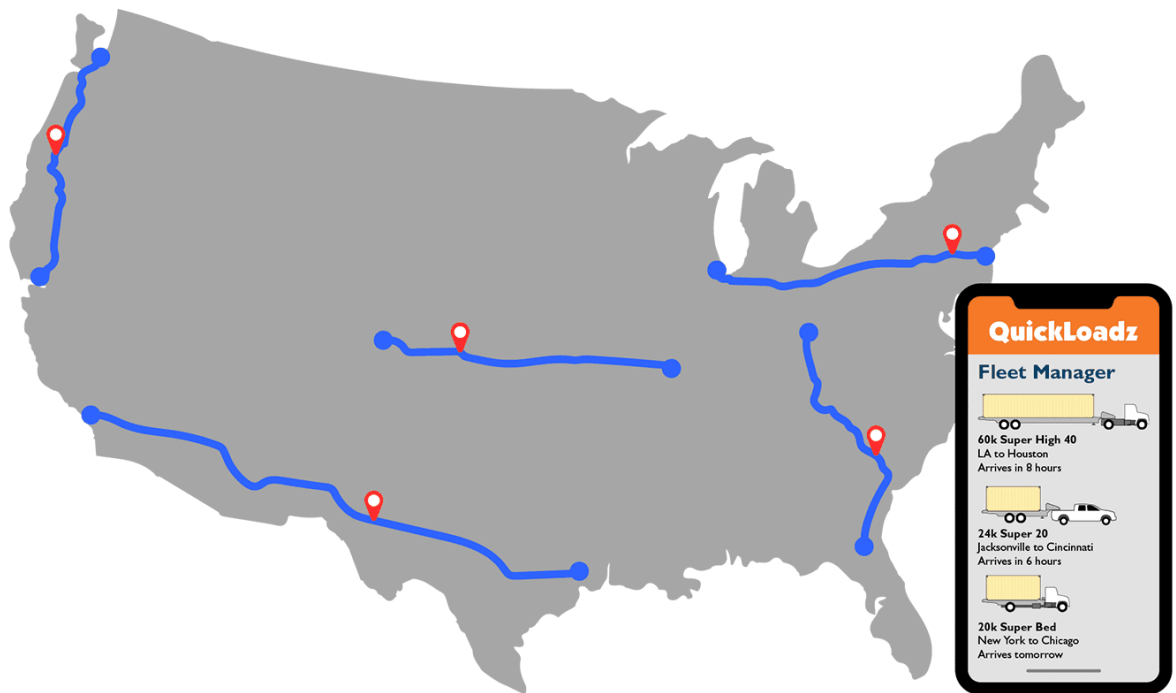

## The QuickLoadz Cloud Logistics Platform.

We're working on a catchier name.

- Every QuickLoadz has a computer with Wi-Fi, cellular and GPS
- With more software, we can create a cloud logistics platform
- Dispatchers can remotely check status of their fleet of QuickLoadz
- Where the trailer is, if the brakes hold air, if there's a flat tire, what its status is, where it dropped off its container, if there's an accident

### Market

## Transport and logistics is a \$9.6T market ripe for tech disruption

Companies like Tesla, Waymo, TuSimple and Aurora are spending billions of dollars on developing the self-driving truck. That's only half of the job: our aim is to **leverage the billions spent on autonomy and transport logistics**. With **our self-delivering load technology**, QuickLoadz does the rest.

**QuickLoadz completes container movement.**

## Help clear worldwide port congestion.

Ports are overwhelmed and are turning to automation to increase efficiencies. Quickly moving containers on the ground is the key.



## Leverage billions spent on automation.

Toyota, Volvo and OutRider are pouring billions into autonomous solutions for ports and distribution centers. QuickLoadz completes this automation.



## OutRider's solution for distribution centers.

QuickLoadz expands OutRider's solution to use sea shipping containers at ground level, trading the \$18,000 container and chassis for \$3,000 containers while expanding OutRider to ports.



Toyota and Volvo's systems require a crane





## to unload.

An automated platform only solves a small part of the problem. Couple a QuickLoadz with their solutions, and suddenly, the entire port opens up.

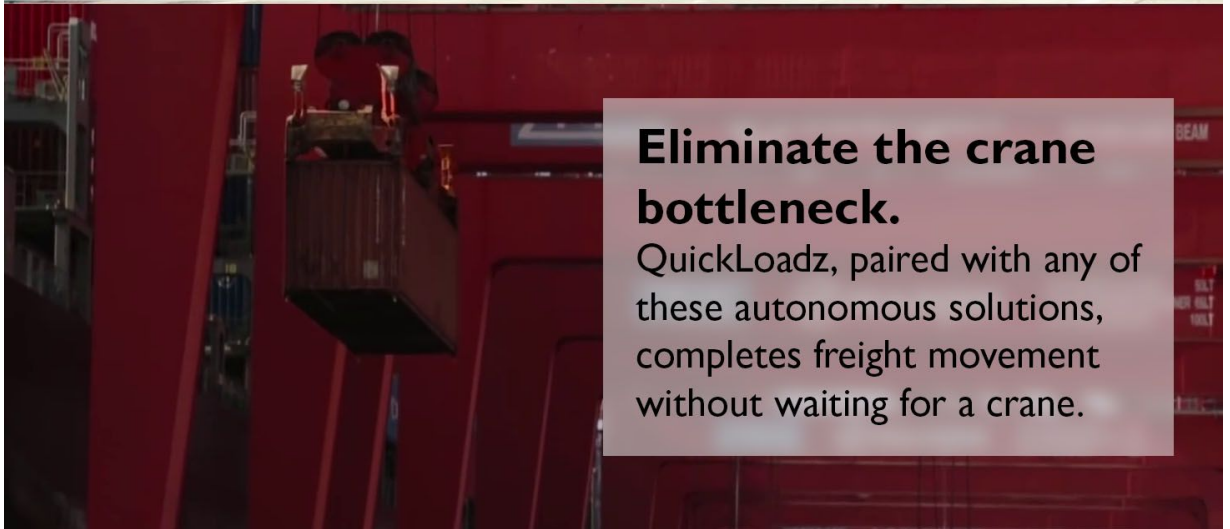

## Eliminate the crane bottleneck.

QuickLoadz, paired with any of these autonomous solutions, completes freight movement without waiting for a crane.

### Competition

## Blazing a new trail in the shipping world

Even though there are less expensive options to move empty containers, it still makes fiscal sense to purchase a QuickLoadz. Our system takes a difficult, dangerous 30 minute job using chains, winches and straps, and turns it into 3 minutes of pushing buttons on a smartphone.

### Costly alternatives



## Tow Trailer

- Only moves empty shipping containers
- Before moving, they must be emptied completely
- As you can imagine, that is extremely inconvenient
- Tow trailers have no way of pushing containers off the bed, so they must hang over the back of the trailer
- This is why they are only allowed to be transported empty



- Cannot load or unload container from itself without crane, forklift
- Container contents are trapped four feet in the air
- Can only unload at a loading dock and with expensive equipment
- Loading docks take hours to open up and hours to unload
- Chassis, truck and driver spend hundreds of hours a year waiting for their cargo to be handled instead of moving that cargo





- Also moves loaded containers without extra equipment
- Operator must control two heavy cranes on both sides simultaneously with the container precariously suspended by chains
- 2× the weight, 2× the price and 10× slower than QuickLoadz while requiring more training, maintenance and inspections regularly
- Not compatible with loading docks—there's a crane in the way

## **QuickLoadz**



**QuickLoadz**

- So automated, the driver never has to leave their seat in the truck
- Fully compatible with existing freight systems like loading docks
- Turns dangerous 30 minute job into 3 minutes of pushing buttons
- QuickLoadz customers move 2 extra containers a day
- Translates to \$100,000 extra income, four month ROI
- QuickLoadz owners see reduced driver turnover, saving thousands

QuickLoadz customers are able to do 2 more container moves a day with QuickLoadz. That translates to \$100,000 per year additional income from using a QuickLoadz over a winch trailer.



## Vision

# Creating the world's new freight and logistics platform

*Our mission is to **change the world of freight and logistics** by creating an automated way of moving sea shipping containers.*

The intermodal shipping container was invented in 1956. This simple idea of putting the merchandise in big steel boxes, instead of hand-carried on ships, entirely opened up world trade. By some estimates, the cost of international shipping dropped by 90%.

However, the handling of these containers hasn't significantly changed in 50 years. Containers still require giant cranes, loading docks and distribution centers to access their contents—until QuickLoadz Intermodal Robotics.

# QuickLoadz Intermodal Robotics

automates the movement of shipping containers and allows them to be moved from carrier to carrier in 3 minutes.



Not only does QuickLoadz streamline the movement of sea shipping containers for existing companies, QuickLoadz expands the use of intermodal freight to those that never have had access to it. Small businesses and emerging business empires can suddenly receive and ship freight just like large companies on the most efficient freight system ever devised, intermodal.

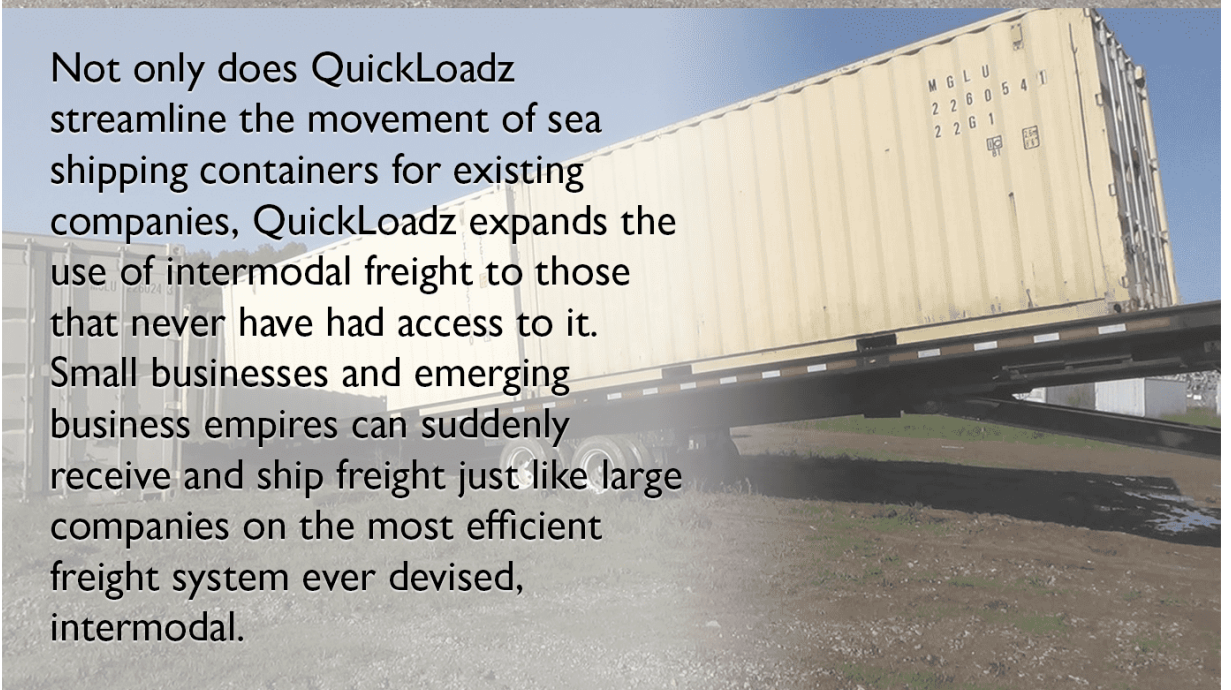

Pair any QuickLoadz with the self-driving truck and you have **end-to-end autonomous** movement of freight.

Add the Stealth 40, an all-electric trailer with Hybrid Power Axles, and you effectively turn **any semi** into a hybrid vehicle.



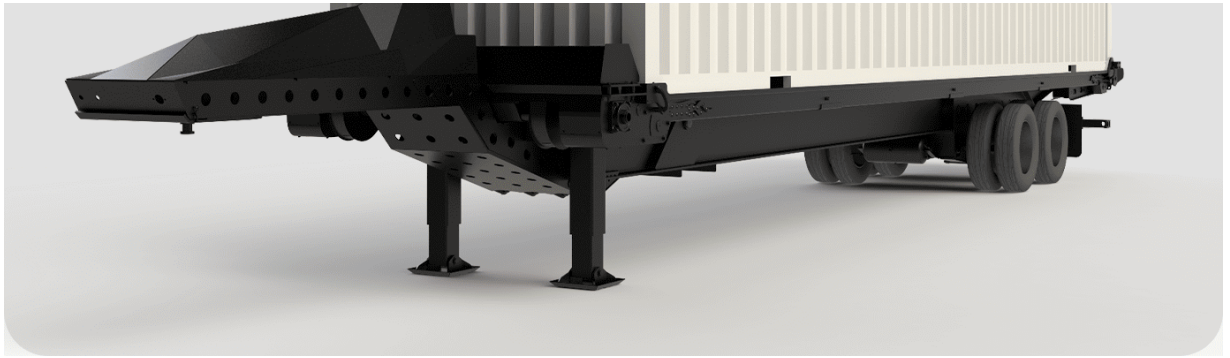

## Investors

### Raising to accelerate production and scale

QuickLoadz has been **entirely bootstrapped** until this raise.

QuickLoadz founders Sean Jones and Bridget Lair have invested \$2,793,386 in personal cash into QuickLoadz.

In addition, QuickLoadz has a \$2,850,000 loan, which it used to purchase and renovate its new 47,000 square foot facility.

QuickLoadz is raising money to scale production, add sales and marketing staff, and let the world know that there is now an easier way to move the 168,000,000 containers that are the basis of world trade.

## Founders

### Led by a serial entrepreneur with many successful exits



#### Sean Jones has a strong history of working on entrepreneurial ventures:

- *Swindlefish Saloon*—live music and dance bar
- *Rockside Rentals*—over a dozen profitable student rental housing assets renovated and sold
- *Rockside Storage*—mobile storage monopoly sold to national leader
- *Rockside Construction*—housing contractor work

#### Awards and Recognitions

- Electrical Engineering with Honors, Ohio University

- Awarded Stocker Fellowship from Ohio University
- Entrepreneur of the Year Award, TechGrowth Ohio

---

## Team



Sean  
Jones

Chief  
Executive  
Officer

Serial entrepreneur in construction, mobile storage with many successful exits.



Bridget  
Lair

Chief  
Financial  
Officer

Co-founder and data scientist, research analyst with Master's degree in global development.



Ash  
O'Brien

Director of  
Operations



Ben  
Vancouver

Production  
Manager



Phoenix  
Jones

V.P. of  
Engineering

---

## Perks

**\$1,000**

The QuickLoadz building brick toy. This 77-piece Lego™-compatible set is a replica of the 24k Super 20 trailer with Gooseneck Coupler. The fully constructed model has many of the features of the real model: a tilting bed, Lift Wedges and the Brain Box (non-functional).

---

## FAQ





Sean Jones <sjones@quickloadz.com>

### A solution to the supply crisis

Sean Jones <SJones@quickloadz.com>  
To: Sean Jones <SJones@quickloadz.com>

Thu, Jan 27, 2022 at 4:45 PM

----- Forwarded message -----

From: **QuickLoadz** <gjones@quickloadz.com>  
Date: Tue, Nov 16, 2021 at 10:02 AM  
Subject: A solution to the supply crisis  
To: [sjones@quickloadz.com](mailto:sjones@quickloadz.com) <[sjones@quickloadz.com](mailto:sjones@quickloadz.com)>

**Invest in the company that could solve the port crisis and automate the future.**

Shipping containers are backed up.

One company builds the trailer that can automatically move shipping containers in minutes. **Fox Business** has the story, with Jeff Flock:



**You can invest in QuickLoadz.**

Invest in the company that can complete the new world of freight. You can invest with just \$150. We have a crowdfunding campaign on Republic.co

right here: <https://republic.co/quickloadz>

[More Information](#) • [Help Me Choose](#)

*"If you move containers, you need QuickLoadz. It is the fastest, safest, simplest system for moving sea shipping containers ever devised."*

Sales Team

888 304 3946 ext 1

[sales@quickloadz.com](mailto:sales@quickloadz.com)

[www.QuickLoadz.com](http://www.QuickLoadz.com)

If you would no longer like to receive these emails, [click here to unsubscribe](#).

--  
cid:image001.png@01D49911.4B318FA0  
Sean Jones  
SJones@QuickLoadz.com  
CEO QuickLoadz Container Moving Systems  
888 304 3946 ext 4  
5850 Industrial Drive  
Athens, OH 45701



---

**QuickLoadz**  7A03C172FF304538B4B12A5C47B5983D.png  
7K