



Berylline

An Excellent Investment Opportunity

Contact
Dennis Dresser
President

248-343-3074

dmdresser@comcast.net
www.beryllineusa.com

The Problem

I am a Boomer, a Biker

I loved to ride!

It was cool and fun!

But, I can't hold a big bike as I used to...

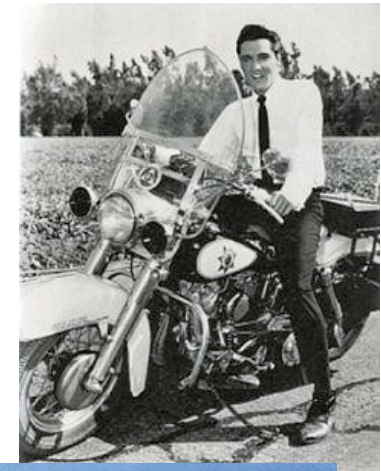
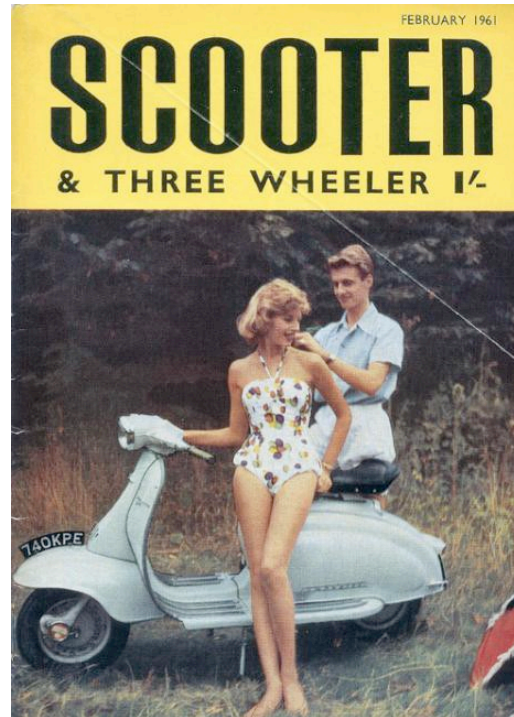

Current Solutions

I want something:

- Looks cool and fun to ride
- Easy to use
- Inexpensive
- “Green” and Great for next generation

There is nothing available in marketplace today!



\$4,999



\$18,995



\$23,349



\$34,339



he Solution

erylline F2A Hybrid cooter

Plug-in Parallel Hybrid System (PHEV)
200cc Engine and 2 KW AC Motor
Top Speed/Hybrid Mode: 60 MPH
Top Speed/EV Mode: 30 MPH
EV Range: 20 Miles
100 MPG

96.5"(L) x 59"(W) x 44.1"(H)
(Fits a Full Size Truck with Long Box)
430 LB



Target Market: The Baby Boomers

Smart Money Magazine
The Graying of the Boomers Will Change the World

The Smart Money Is on the 50+ Crowd
Robert Love, AARP The Magazine, June/July 2014

- 50 to 80 Million strong
- Control over 70% of the disposable income
- \$7 Billion just in online shopping
- Third largest economy in the world

THE GRAYING OF THE BOOMERS WILL CHANGE THE WORLD

During the stock market booms of the 1990s and the mid-2000s, many boomers undoubtedly thought their retirement would meld the best of the Buffets (Warren and Jimmy), combining fat portfolios with tropical ease. But since the 2008 crash, many are coping with shriveled savings and diminished expectations. According to a recent MetLife survey, only half feel that their retirement savings are on track. While most are willing to keep working to close their financial gaps, that choice isn't always in their hands. Disability rates for Americans in late middle age are worsening, subjugating many workers' earning power, just when they need it most, says demographer Neil Howe, founder of consulting firm LifeCourse Associates. Multiply these personal challenges by, well, 78 million, and their importance becomes obvious. Already, the cost of Social Security and Medicare benefits for boomers is the angry elephant in the room in any debate over government spending. But there's plenty of silver lining, too. More empty nesters, whether in need of a job or just hankering to be their own boss, are hanging out a shingle—giving the economy a jolt. Indeed, 45- to 64-year-olds composed 48 percent of all new entrepreneurs in 2011. "Contrary to the popular opinion," says Scott Shane, economics professor at Case Western Reserve University, entrepreneurship "increases as people get older." And so, studies say, does happiness: The AARP Thriving index, which measures emotional well-being, suggests that people's happiness reaches its lowest point at ages 51 to 55 and starts peaking after 65.

Steve Jobs was a baby boomer. So are George Clooney, Oprah and the Boss. So are President Obama, Hillary Clinton and Mitt Romney. There's a case to be made, in fact, that the past 20 years represented an apogee for the generation of Americans born between 1946 and 1964—as they reached their peak earning years while taking hold of the levers of corporate, political and cultural power. But for all the clout this generation has wielded in its prime, the way boomers collectively exit their prime could have an even bigger impact on the country. Boomers are plowing into their retirement years, ready or (very often) not. And how they cope with the challenges of the transition will shape our economy for decades to come. After all, at 78 million strong, boomers are a demographic T. Rex whose every move has a ground-shaking impact.

PHOTOGRAPH BY GLENN COOPER



Percentage of baby boomers who expect to work until age 70 or later

Year	Percentage
2006	16%
2011	23%
2016	5%

SOURCE: EMPLOYEE BENEFIT RESEARCH INSTITUTE

Research shows that happiness drops at midlife, but peaks at the start of retirement.

Age	Very Happy (%)
40-45	22%
46-50	17%
51-55	15%
56-60	17%
61-65	18%
66-70	24%

SOURCE: AARP



Market Opportunities

The Niche Market

- Florida roll out (The Villages and Del Webb Communities)

Expand to additional markets

- Southern California, Arizona (Rancho Mirage, Del Webb and Coastal Rental Markets)

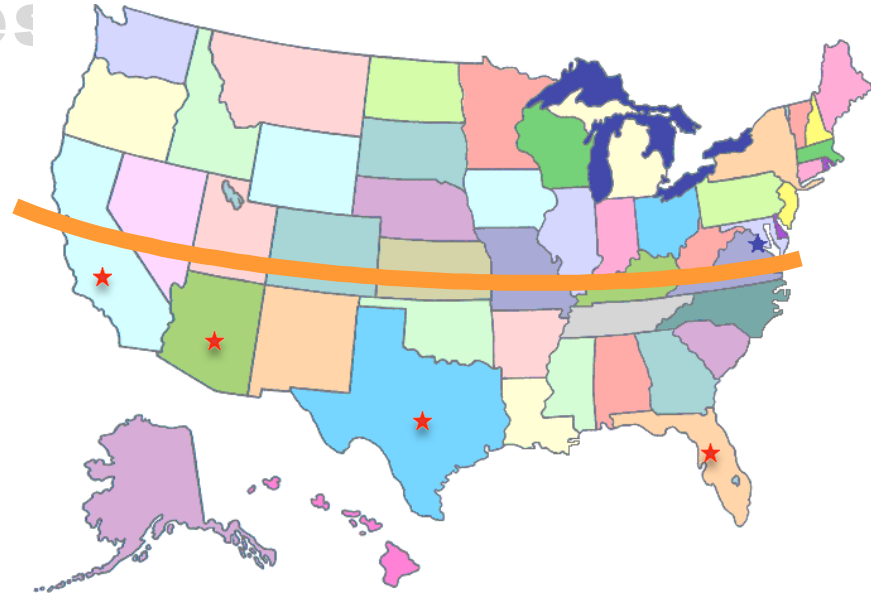

Total Market Size

- Motorcycle/Scooter: Revenue: \$6.3 Billion Total Unit Sale: 500,695
- Golf Cart: Revenue: \$894.2 Million Total Unit Sale: 75,981

Projected Sales: between 5,800 to 11,500 units per year

'raction

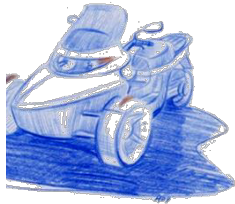

9: Concept /
sibility Study



2011: First Concept
Vehicle Complete

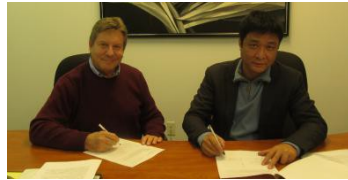

2012: Signed partnership
agreement with Wanhu
Industries in China



2014: Production
Intent prototype
complete



2015 & 2016:
Marketing,
Dealership, and
Geographic
Campaign



2017: Production
Model Design
Update



Team

Chris Dresser, President

Former GT Automotive CEO, 30 Years+ Industry Experience

Sean Chambers, Vice President

Former Alternative Automotive President, 25 Years Of Building Custom Cars

Eric Weber, CFO

Former GT Automotive CFO, 30 Years+ Industry Experience

Henry Li, Chief Engineer

Years in Automotive Styling, Design Release and Manufacturing

Chris Dresser, Sales&Marketing

BA, OU, 6 Years Industry Experience

Steve Nelson, Regional Sales

Years in Sales, Former ATT sales director

Robert Kapatais, Mechanical Design

Years in Mechanical Design

Steve Wilkonski/RDS Studio, Styling

Business Owner, 25 Years in Automotive Design

Kevin Moore, Technician

Years+ In Building and Equipment Maintenance, Motorcycle Repairs

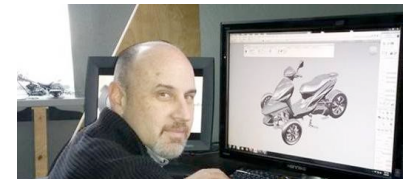
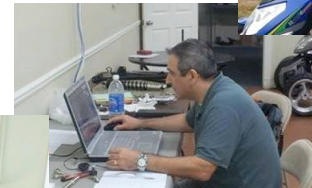

Berylline Supporting Structure

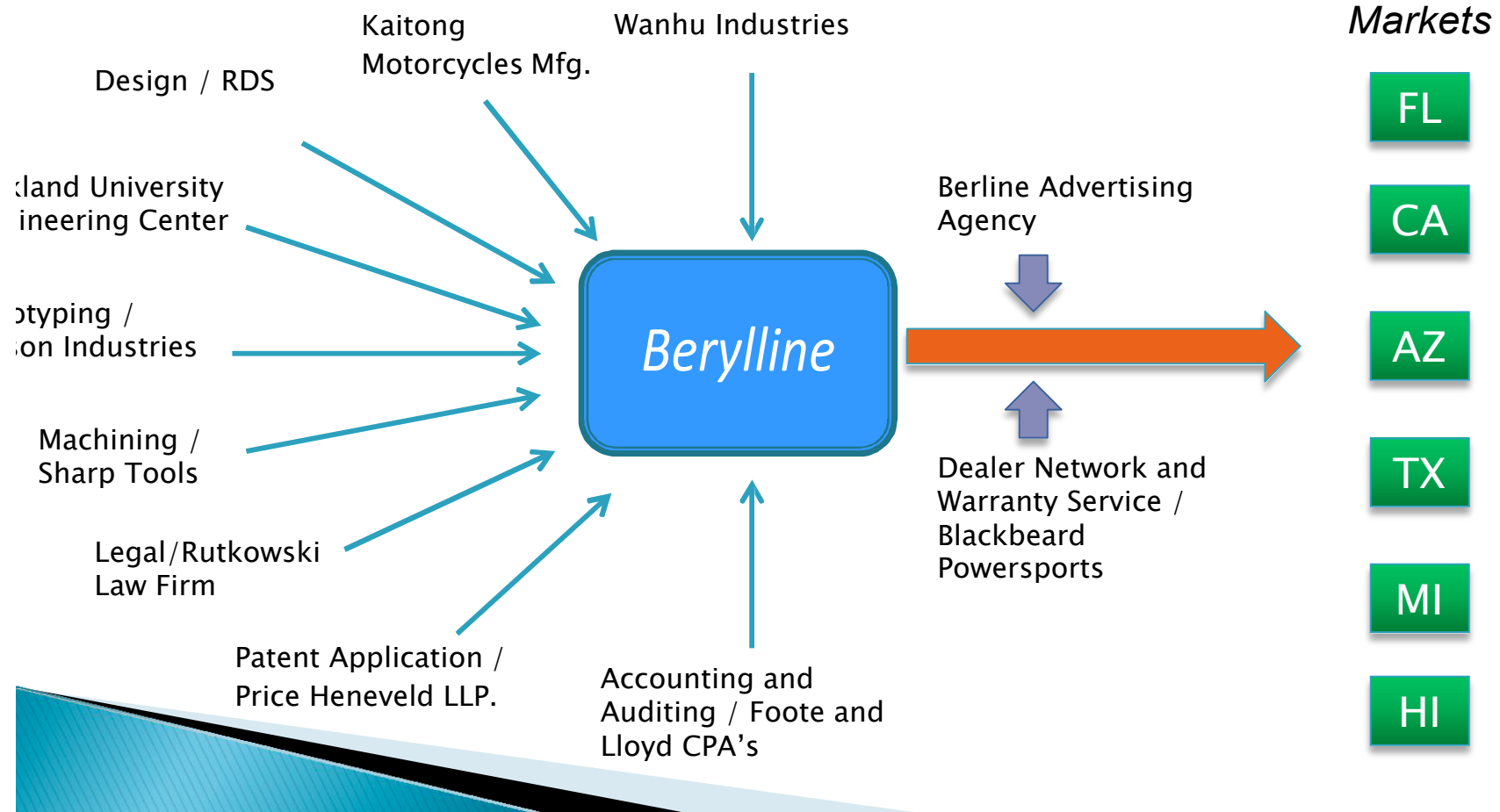

Timeline

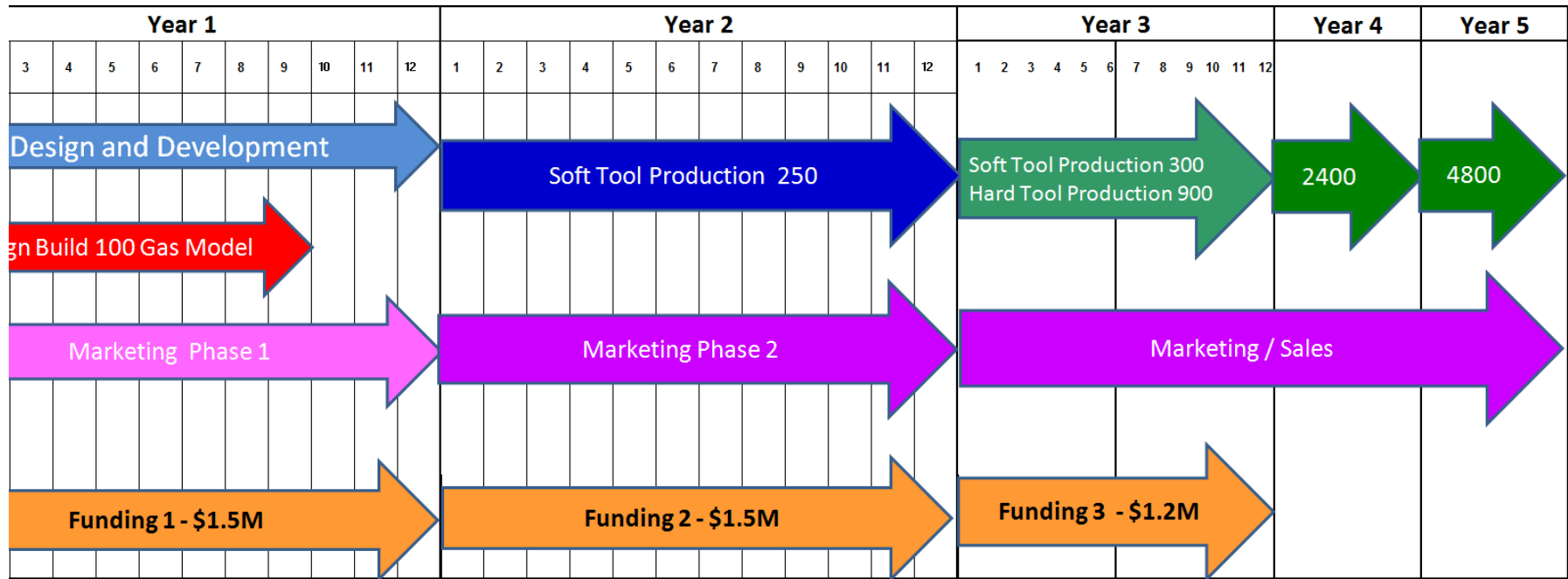

investment

Capital to Raise: \$4.2 Million

Current Investors:

Founder's Cash Investment: \$150,000

Wanhu Industries: \$100,000

MEDC: \$43,600

Key Use of Proceeds:

Product Development: \$1.1 Million

Marketing and Operation \$1.9 Million

Production Tooling: \$1.2 Million

Total: \$ 4.2 Million



Investor Return

Current Status and Valuation

- Production Intent Prototype Completed
- 3 Marketing Studies Completed
- Partnership with WH Industry / China Signed
- Supply Agreement with KT Motorcycle /China Signed
- Oakland University EFI Development Complete

Current Valuation: \$5 Million

End of 5 Year Status and Valuation

- Production 6,000 units
- Revenue \$31.7M

IPO: Company Valuation: \$50 Million

Investment Return in 5 Years: **1,000%**

Berylline Is An Excellent Investment Opportunity

Product Description

Berylline F2A Hybrid Scooter



- Plug-in, 200cc / 2KW Parallel Hybrid Powertrain
- Front 2 Wheel set up with non-tilt and stable in all conditions.
- 2 Function Modes: EV and Hybrid
- Capacity: 2 Passengers / 300LB
- Electric Mode Top Speed: 30 MPH
- Electric Mode Range: 20 Miles
- Gas Mode Top Speed: 60 MPH
- Target Fuel Consumption: 100 MPG*

Product Comparison



Wheel Design Comparison

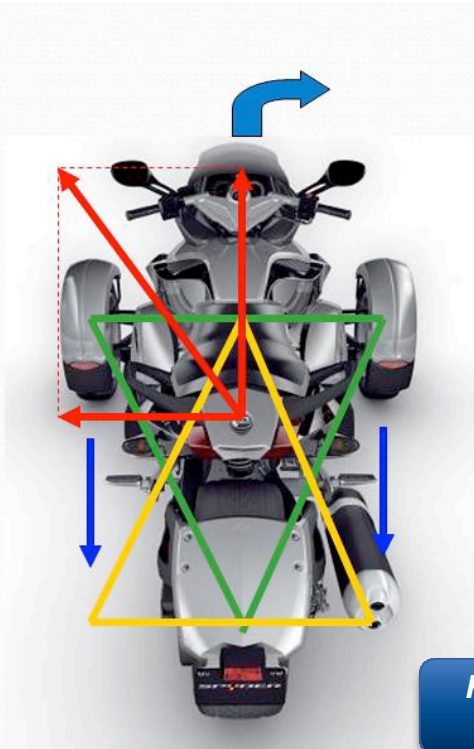

Generally speaking, the difference between Front 2 Wheel Type and Rear 2 Wheels Setup are:

- Front 2 wheel type is safer for cornering.
- Front 2 wheel type has better braking performance because 70% of braking power is from front wheels.
- Front 2 wheel type is safer during emergency braking.

MP3 Like “Lean/Tilt”
Type Vehicle



Front 2 wheel design is more suitable for personal use vehicle, while rear 2 wheel design is fit better for slower commercial type vehicle.

Competition

Competition And Comparison



Berylline F2A

Type: Hybrid
MSRP: \$5,999
Range: 160Miles/1.6Gal.
Top Speed: 60 MPH
Length: 96.5 Inch
Width: 59 Inch



Arcimoto SRK

Electric
\$11,900
70 Miles
85 MPH
106 Inch
61 Inch

Arcimoto recently raised **19.5 million** dollar in its IPO. This further validated the market.



Piaggio MP3 125 Hybrid Scooter

Hybrid
\$9,000
460 Miles /3.3Gal.
50 MPH (est.)
84.25 Inch
30 Inch

Difference of Piaggio MP3 vs Berylline F2A:
MP3 has a leaning front suspension which requires a two wheel scooter riding skill.

The MP3 Hybrid Scooter currently is NOT

die in us

Berylline 3P Hybrid System Layout

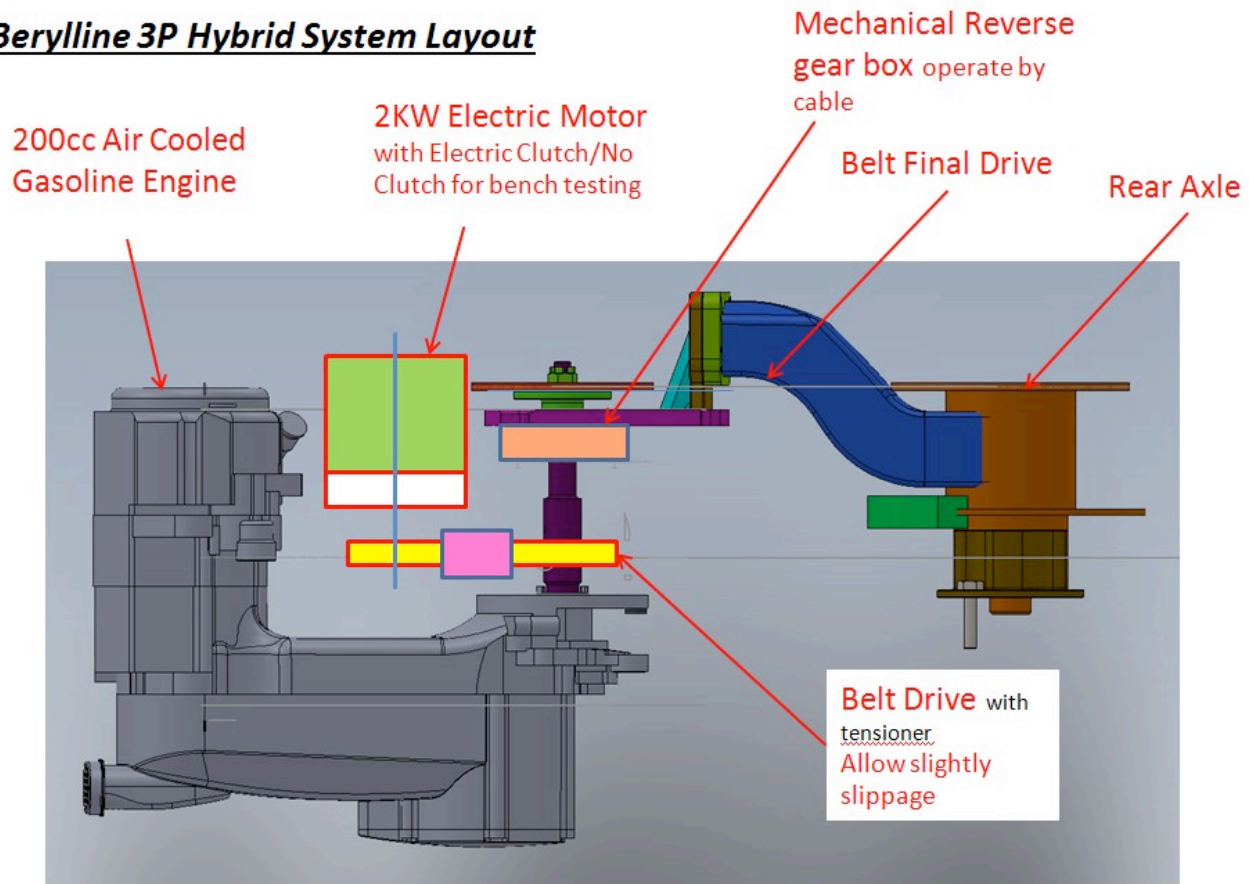

Berylline Hybrid System Objective

Improved overall powertrain performance with higher power output

Reduce overall exhaust emission

Added safety feature: 2 system can be independently operated to provide back up for each other.

Utilize existing technology to improve system reliability

More common components to improve serviceability.

Commercial advantage: Improve the flexibility for Berylline to select supplier in broader base and maintaining the competitive advantage

System Features Comparing to Gasoline Engine:

2KW AC motor designed to work with existing engine.

Provide vehicle launch assist

Provide Re-generative brake feature

Provide EV driving mode.



System Control Design

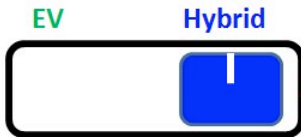

Junction Box

KT Motor Controller

KT System Controller

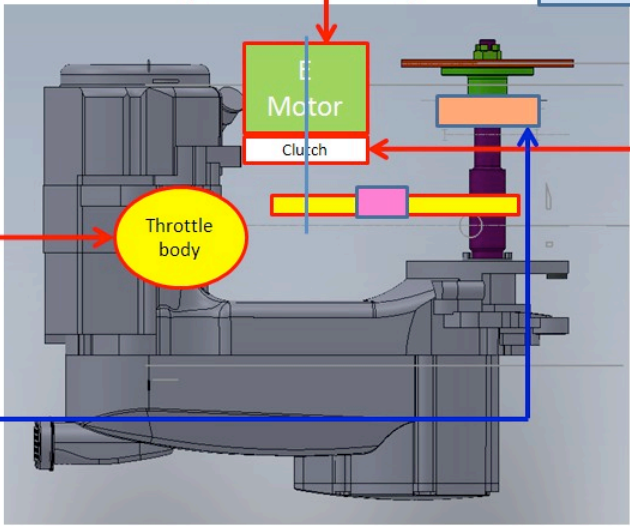

Forward

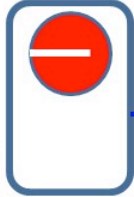

Reverse





Engine Supplier: Zhejiang Jinlang Power Co., Ltd. (Est. Cost: 250USD)

Make	Zhejiang Jinlang Power Co., Ltd.
Model	JL1P65QML
Type	Single cylinder/4-stroke/forced air-cooled
Bore x Stroke	65 x 60 mm
Displacement(ml)	199.1
Compression ratio	9.7:1
Max power(kw/rmp)	9.7/7500
Max torque(N.m/rmp)	13.8/6000
Min idling speed(r/min)	1500

Electric Motor Requirements (Est. Cost: 100USD)

Machine type	BLDC machine
Normal voltage	48V
maximum Current	50A
Efficiency	>80%
Max power(kw/rmp)	2/2500
Max torque(N.m/rmp)	7.6Nm/2500
Maximum speed(r/min)	7500rpm

Hybrid Systems

Ferrari LaFerrari

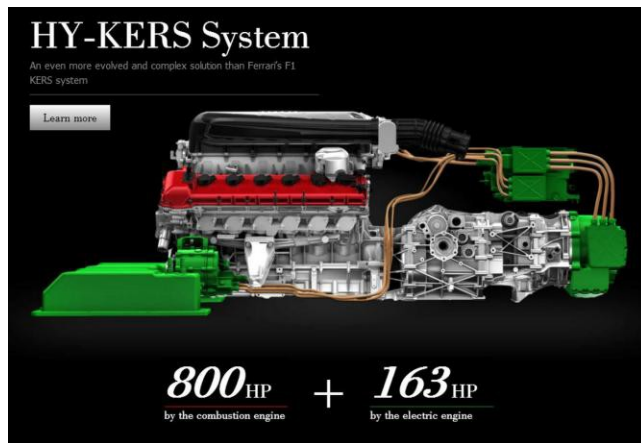

Honda/Acura NSX

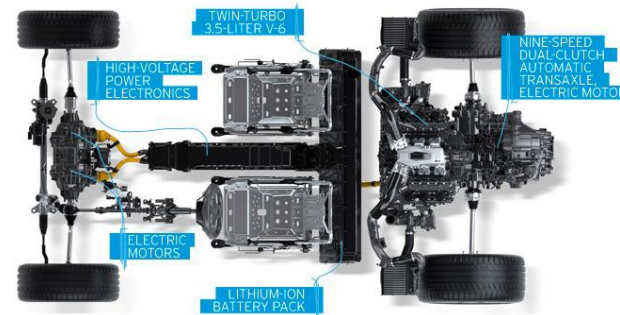

ew Product Design Update



Future Product Expansion



Pure Electric



Gasoline



Removable Roof



Berylline Future Product Plan

(Confidential)

F2A, 200cc Engine + 2KW Motor



Common Chassis



F2B, 50cc Engine + 1KW Motor

Berylline 3P Flex Hybrid System

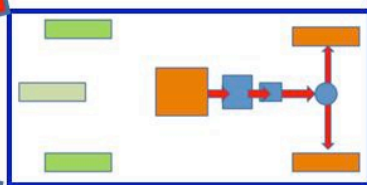

G4: 4 Wheel Hybrid Golf Cart for US



U4: 4 Wheel Utility Vehicle for US



Berylline WH Commercial 3 wheel vehicle

Berylline Accessory Plan

(Confidential)



Detachable Roof with Solar Cell



Detachable Front Rack (F2A)



Detachable Golf Bag Case (F2A)



Custom Seat
with Backrest



Detachable Rear
Storage Case



Berylline Helmet



Berylline Jacket and T-Shirt



Berylline Commercial Vehicle Application 1



Berylline Commercial Vehicle Application 2

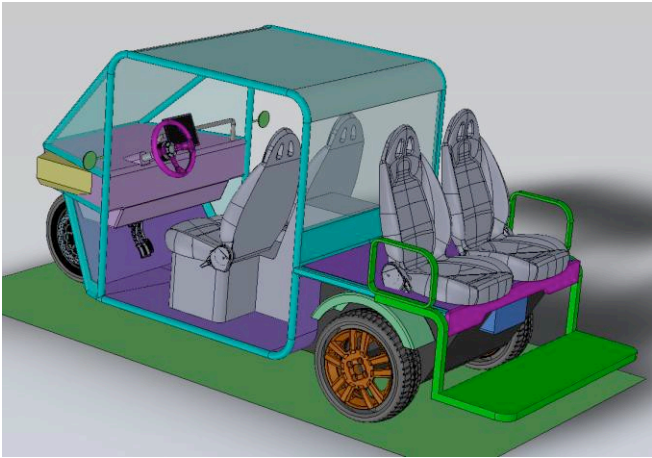
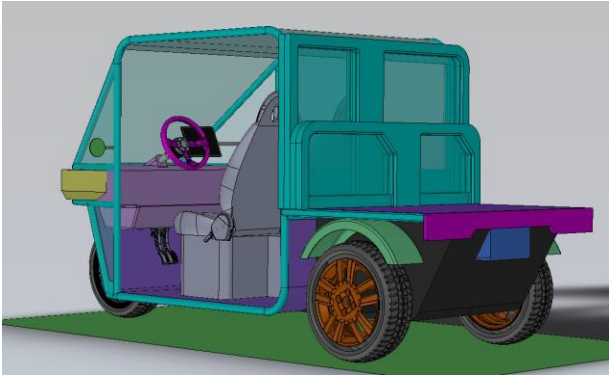

Marketing Segmentation

Berylline
F2A
Scooter



Personal

Berylline
Commercial
Vehicle



Commercial

Manufacturing Planning: New Parts and Process

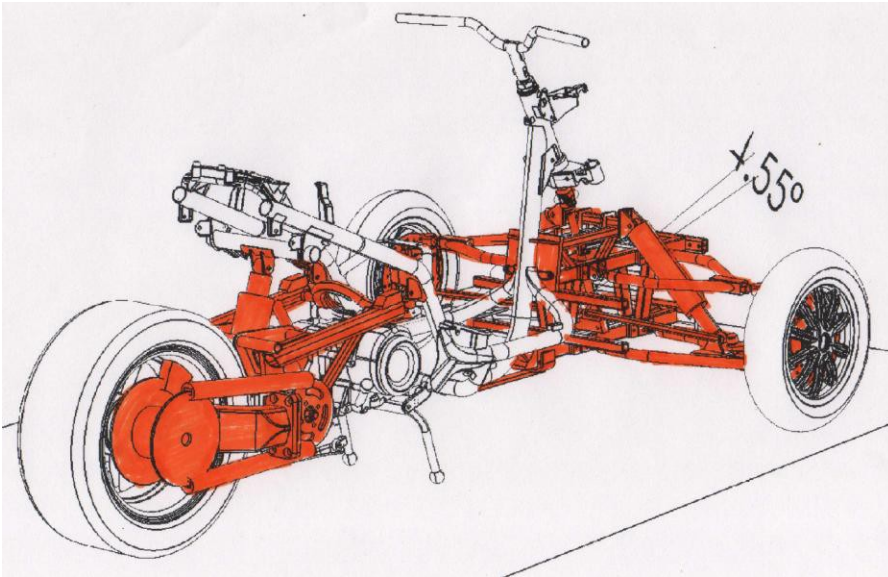

Station	Job Description	Tool
1	Unboxing	
	Load base scooter to fixture	Load assist with end effector
2	Install LH and RH LCA	Processing fixture/Cart
	Chassis	Air RA SS1
		Torque check/Click wrench1
	Install LH and RH UCA	Air RA SS1 (Same tool)
	Install LH/RH front knuckle	Torque check/Click wrench1 (Same Tool)
	Install LH/RH LCA/LCA cotter pins	Air RA SS
	Torque check/Click wrench2	
3	Flip both UCA/LCA detail, Install LH/RH Shock/Spring Amy.	Plier1
	Chassis	Air RA SS
		Torque check/Click wrench3
	Install LH/RH Tie Rod	Air RA SS
	Install Tie Rod cotter pins	Torque check/Click wrench3
	Connecting/Secure LH/RH brake hose	Pliers
Bleeding Frt Brake	Hand Tube Nut Wrench	
4	Install LH/RH supporting brackets	Hand Wrench
	Trim	Air Pistol
		Install LH/RH food board
	Install front exterior sub frame	Air RA SS
	Sub assemble LH/RH running lights to front fascia	Air Pistol
	Install front fascia	Air Pistol
Connecting Harness to LH/RH running lights		
5	Install hood	Air Pistol
	Install Tire Asm	Air Pause Pistol
	Final	Torque check/Click Wrench
Sub Assemble LH/RH Fender to bracket		Air Pistol
Install LH/RH Fender		Air RA SS
6	Transfer vehicle to Alignment Machine	Lift Assist with end effector
	Set front Alignment, Camber and Toe	Hand Wrench
Alignment	Roll vehicle to floor	
	7	Add 0.3 Gal. Gas
QA	Starting vehicle and check all electrical functions.	
	0.5 mile road testing.	
8	QA: Light Repairs	
9	Crating	Load Assist with End effector

Manufacturing Planning: R&D, Future Facility Expansion

Phase 1: Michigan Assembly
Future R&D Center

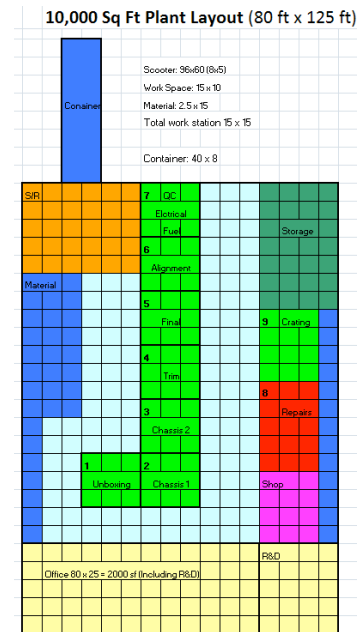

Phase 2 Manufacturing Expansion:

Metal Stamping Solution (40,000 Sq Ft)
5720 Clyde Rhyne Dr,
Sanford, NC 27330

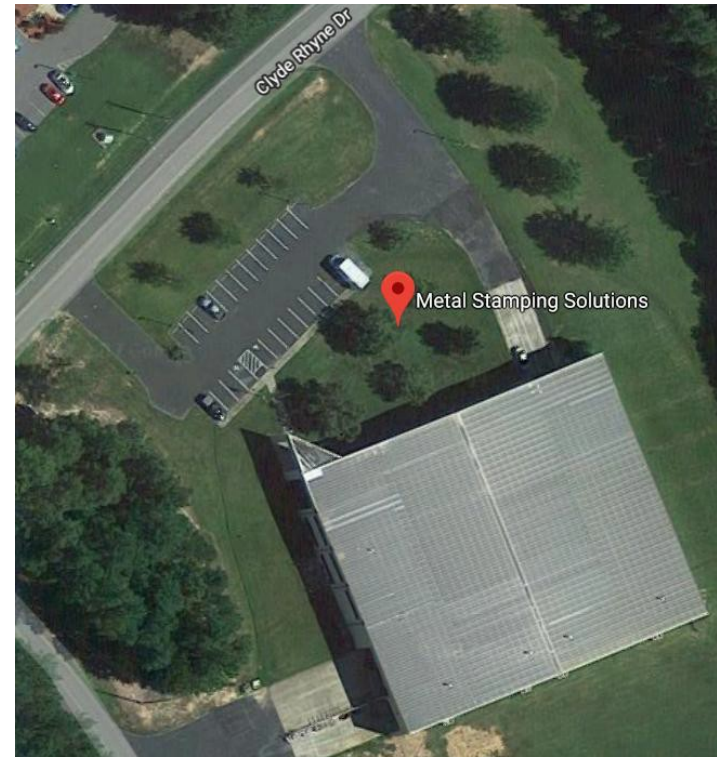
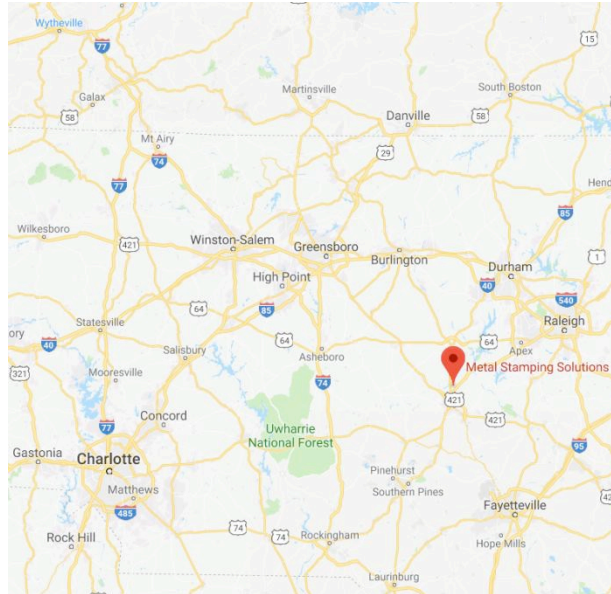

**Marketing Strategy and
Case Study: The Villages**



Market Opportunities

The BERLINE Marketing Report

(available Upon Request)

Berline Group is founded in 1982. It is a full-service marketing, advertising and digital communications firm with annual billings in excess of \$50 million.

<http://www.berline.com/>

7 Potential Target Market Segment Identified

1. Retired seniors living in senior communities.
2. Active senior motorcyclists who want to continue or relive that experience.
3. Adults with vacation/second homes who would consider the Berylline for convenience, sport and economy.
4. Returned / Former motorcycle riders (licensed) who want a safer, less risky experience.
5. Rental companies can offer the Berylline as an economical alternative for local/temporary urban transportation in addition to campgrounds, parks, and tourist destinations.
6. Adults who are reluctant to ride a motorcycle will consider the Berylline because of the safety, speed, and energy benefits.
7. Adults who are interested in the motorcycle experience and were especially motivated by the hybrid capability of the Berylline.

- **Total Market Size**

- Motorcycle/Scooter: Revenue: \$6.3 Billion Total Unit Sale: 500,695
- Golf Cart: Revenue: \$894.2 Million Total Unit Sale: 75,981

- **Projected Sales: between 5,800 to 11,500 units per year**



2 Previous Survey Age Group Data

Troy Traffic Jam - Classic Car Show
August, 2015, Troy, Michigan

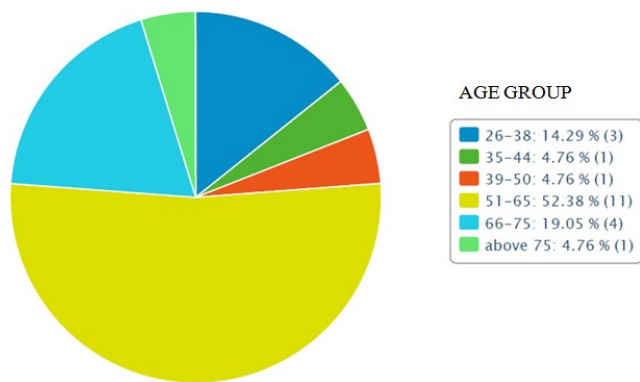

Woodward Dream Cruise - 2015
August, 2015, Birmingham, Michigan

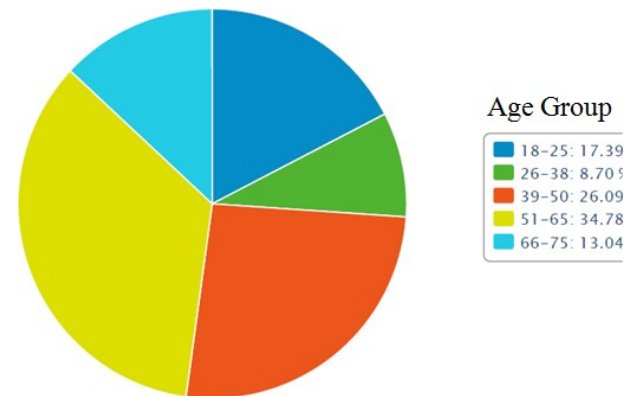

The Fastest-Growing U.S. City Is a Senior Community

Americans over 55 are flocking to the Villages, a sprawling retiree utopia that just keeps growing

by Patrick Clark

[Play Video](#)

Case Study: The Villages, Florida

The latest estimates from the U.S. Census Bureau are in, and the fastest-growing city in the U.S. is not an oil boomtown or a magnet for new immigrants, but a senior living community outside Orlando, Fla., with a reputation for attracting active retirees.

The Villages, a sprawling senior community of 114,000 residents, increased 5.4 percent in the year ended July 2014, making it the country's fastest-growing metro for the second straight year. That's triple the growth rate for the state of Florida and far faster than Myrtle Beach, S.C., the second fastest-growing U.S. city, which expanded 3.2 percent.

America's Fastest Growing Cities

Estimated population growth for the year-ending July 1, 2014

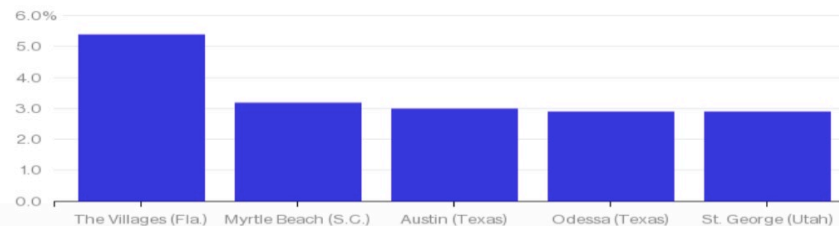

Financial



Financial

Year Income Statement

Unit Cost:	\$2967
Shipping and Warranty:	\$350
MSRP:	\$5,999
Dealer Profit Margin:	\$900
Unit Profit:	\$1,782 (29.7%)
Break Even Point:	860 Units

	2018	2019	%	2020	%	2021	%	2022	%
Total Unit Sale	0	250		1200		2400		4800	
F2A Sport	0.0	0.0		1,799,700.0		3,599,400.0		7,198,800.0	
F2A Tour	0.0	1,749,750.0		6,299,100.0		12,598,200.0		25,196,400.0	
Accessories	0.0	50,000.0		240,000.0		480,000.0		960,000.0	
Less: returns	0.0	(87,487.5)		(404,940.0)		(809,880.0)		(1,619,760.0)	
Total Sales	0.0	1,712,262.5	100%	7,933,860.0	100%	15,867,720.0	100%	31,735,440.0	100%
Cost Of Sales									
Total Cost of Sales	80,144.2	1,443,085.1	84%	6,068,887.4	76%	11,675,082.7	74%	22,688,973.3	71%
Gross Margin	(80,144.2)	269,177.4	16%	1,864,972.6	24%	4,192,637.3	26%	9,046,466.7	29%
Selling, General & Admin Costs									
Total S,G & A Costs	788,260.0	1,104,759.4	65%	1,418,259.4	18%	2,028,759.7	13%	2,381,260.0	8%
Operating Income (Loss)	(868,404.2)	(835,582.0)	-49%	446,713.2	6%	2,163,877.6	14%	6,665,206.7	21%
EBITDA	(872,804.2)	(835,582.0)	-49%	436,713.2	6%	2,138,877.6	13%	6,640,206.7	21%
Net Income (Loss)	(872,804.2)	(835,582.0)	-49%	436,713.2	6%	1,844,028.0	12%	4,382,536.4	14%

Arcimoto Raises \$20 Million in Reg A+ Crowdfunding Offer, Will Trade on ASDAQ Under Symbol FUV

1 f 12 in 58 G+ 2 t Y 73 SHARES

September 20, 2017 @ 1:38 pm By JD Alois



Arcimoto says it raised almost \$20 million in a Reg A+ crowdfunding round that closed on September 15th

WR Hambrecht. Arcimoto said the company was shooting for \$10 million but "landed almost double that". Arcimoto added that it will trade on NASDAQ under ticker symbol FUV (IE Fun Utility Vehicle) reportedly tomorrow (September 1st).

CASE STUDY: ARCIMOTO

Arcimoto, Inc. (FUV)

NasdaqCM - NasdaqCM Delayed Price. Currency in USD

[Add to watchlist](#)

3.88 +0.14 (+3.74%)

At close: January 8 3:59PM EST

- Summary
- Chart NEW
- Conversations
- Statistics
- Profile
- Financials
- Options
- Holders
- Historical Data
- Analysts

Previous Close	3.74	Market Cap	61.583M
Open	4.12	Beta	N/A
Bid	2.72 x 1000	PE Ratio (TTM)	N/A
Ask	5.94 x 200	EPS (TTM)	-0.19
Day's Range	3.73 - 4.12	Earnings Date	N/A
52 Week Range	2.54 - 6.35	Forward Dividend & Yield	N/A (N/A)
Volume	65,274	Ex-Dividend Date	N/A
Avg. Volume	51,156	1y Target Est	N/A



Trade prices are not sourced from all markets