

KNOW
HOW
good
YOUR
network
CAN BE.™

TOLLGRADE™

Enabling the Digital Edge

*Tollgrade's strategy
for long-term growth*

TOLLGRADE®

KNOW
HOW
good
YOUR
network
CAN BE.™



Our Customer's Network

TOLLGRADE

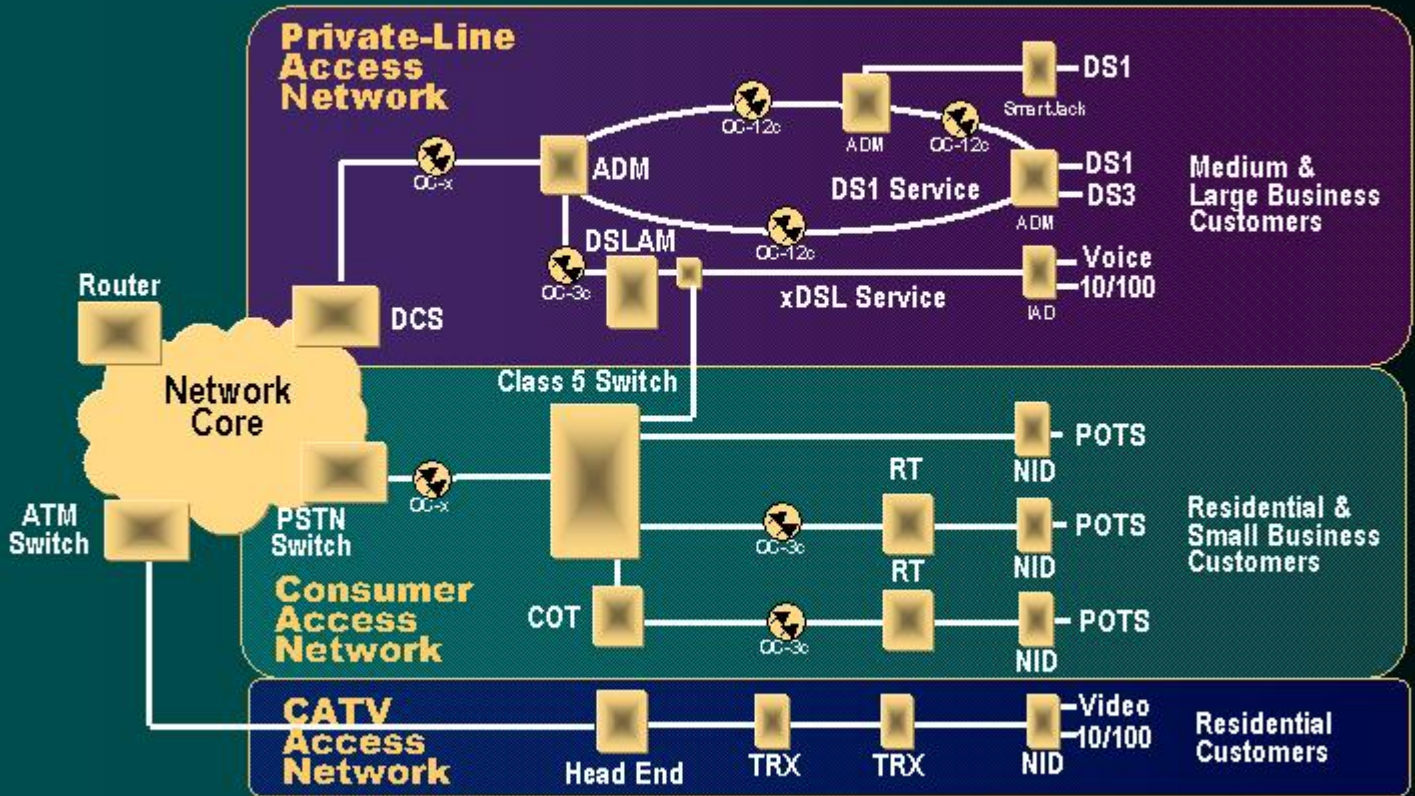

64RD 092 01 3

Core Product Families

Broadband Edge T&M Solutions



Consumer Access T&M Solutions



Lucent LoopCare*
Nortel AccessCare*



CATV Access T&M Solutions



Professional
Services

*Per OEM/Reseller Agreements.

Revenues by Product Family (dollars in millions)

TOLLGRADE

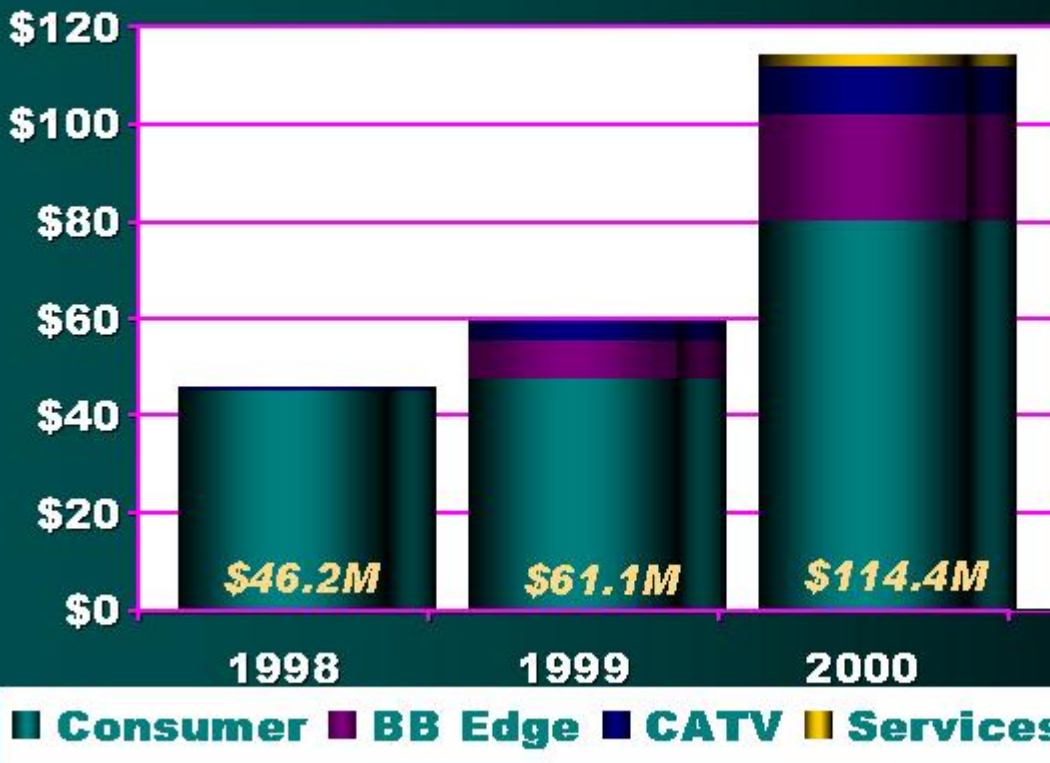

KNOW HOW
good
YOUR
network
CAN BE.™

64RD 092 01 5

Our Focus Moving Forward

Providing our customers with leading edge test & management solutions which...

- Enable the competitive rollout of digital broadband services.
 - High Speed Internet
 - Voice over Broadband
 - Digital Video
- Fully leverage the investments in their existing access network infrastructure.
 - Incumbent Centralized Test & Management Systems
 - Recently Deployed DSLAMs and NGDLCs

64RD 092 01 6

KNOW
HOW
good
YOUR
network
CAN BE.™



A Shift in the Market

- Currently, the market is shifting from a focus of *building capacity* in the network's core to *filling capacity* at the edge.
- **As a result...**

KNOW
HOW
good
YOUR
network
CAN BE.™

...Our Customers are Buying More...

TOLLGRADE

DLC Equipment

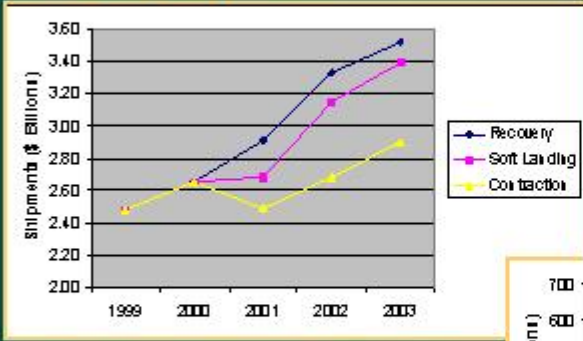

Source: RHK Telecommunications Industry Analysis

IAD/Gateways

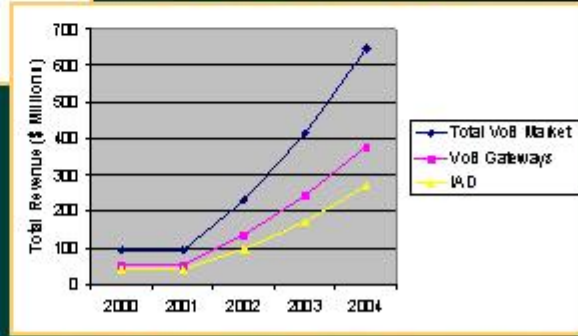

Source: RHK Telecommunications Industry Analysis

64RD 092 01 8

KNOW
HOW
good
YOUR
network
CAN BE.™



...to Drive Increased Deployments of...

TOLLGRADE

Internet Services

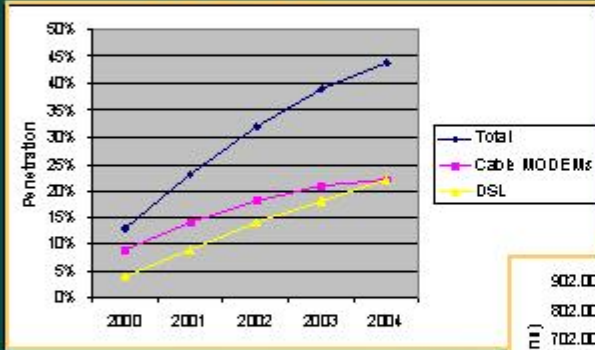

Source: RHK Telecommunications Industry Analysis

VoB Services

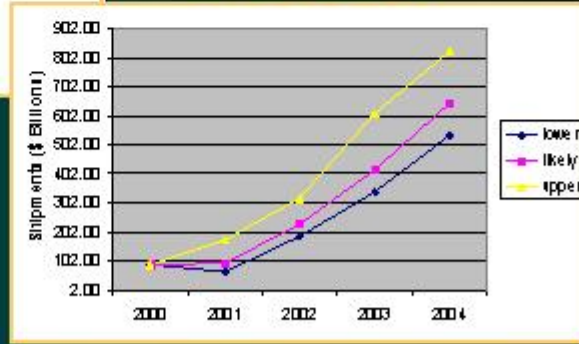

Source: RHK Telecommunications Industry Analysis

64RD 092 01 9

KNOW
HOW
good
YOUR
network
CAN BE.™



The Positive Impact

- This increased investment in the broadband edge provides unique growth potential for Tollgrade by leveraging:
 - *Its market dominance – in partnership with Lucent – with Consumer Access T&M solutions.*
 - *Its unmatched ability to integrate test into access network elements, including NGDLCs and DSLAMs*
 - *Its company-wide applications knowledge of testing broadband services over the copper/coax loop.*

BARD 092 11 10

KNOW
HOW
good
YOUR
network
CAN BE.™



Our High-Level Strategies

- ***Digital LTS***
 - Enable the RBOC's competitive management of the Digital Consumer through the evolution of their existing Consumer Access T&M solutions.
- ***IMU Anywhere***
 - Maximize the global presence of Tollgrade's broadband edge solutions through win/win relationships with industry leading Access Network Element and Private-Line T&M suppliers.
- ***Digital w/o a Dispatch***
 - Enable our customer's ability to accelerate broadband service deployments by enhancing their existing access network T&M solutions to include IP/ATM service verification.

KNOW
HOW
good
YOUR
network
CAN BE.™



Financial Statements

Balance Sheet (Dollars in Thousands)

June 30, 2001

December 31, 2000

Assets

Current Assets

Cash and Investments	\$76,417	\$58,830
Accounts Receivable	18,190	19,590
Inventories	24,980	30,499
Other	2,201	10,721

Total Current Assets	\$121,788	\$119,640
-----------------------------	------------------	------------------

Other	\$17,664	\$11,635
-------	----------	----------

Total Assets	\$139,452	\$131,275
---------------------	------------------	------------------

Financial Statements

Balance Sheet (Dollars in Thousands)

	June 30, 2001	December 31, 2000
Liabilities and Shareholders' Equity		
Total Liabilities	\$5,003	\$8,515
Total Shareholders' Equity	\$134,449	\$122,760
Total Liabilities and Shareholders' Equity	\$139,452	\$131,275

Financial Statements

Statement of Cash Flows (Dollars in Thousands)

First Half 2001

First Half 2000

Cash Flows from Operating Activities

Net Income	\$9,559	\$12,378
Adjustments to reconcile Net Income to Cash	13,979	<2,161>

Net Cash Provided by Operating Activities

\$23,538 \$10,217

Cash Flows from Investing Activities

Capital Expenditures	<\$2,436>	<\$2,217>
----------------------	-----------	-----------

Cash Flows from Financing Activities

Proceeds from the exercise of Stock Options	1,045	8,742
---	-------	-------

Financial Statements

Statement of Cash Flows continued (Dollars in Thousands)

	First Half 2001	First Half 2000
Net Increase in Cash and Cash Equivalents	22,147	16,742
Cash and Cash Equivalents at Beginning of Period	61,580	31,922
Cash and Cash Equivalents at End of Period	\$83,727	\$48,664

Financial Statements

Second Quarter Statement of Operations (Dollars in Thousands)

	2001 Actual	% of Total Revenue	2000 Actual	% of Total Revenue
Net Product Sales	\$ 21,776	100%	\$ 29,667	100%
Gross Profit	\$12,211	56.1%	\$ 18,253	61.5%
Total Operating Expenses	\$ 6,704	30.8%	\$ 7,621	25.7%
Net Income	\$ 3,803	17.5%	\$ 7,154	24.1%
Weighted average shares and equivalents: diluted	13,404,290		13,318,461	
Diluted E.P.S.	\$.28		\$.54	
Analysts Consensus Estimate (excluding charge)	\$.30			

Financial Statements

First Half Statement of Operations (Dollars in Thousands)

	2001 Actual	% of Total Revenue	2000 Actual	% of Total Revenue
Net Product Sales	\$ 49,766	100%	\$ 52,084	100%
Gross Profit	\$27,926	56.1%	\$ 32,299	62.0%
Total Operating Expenses	\$14,043	28.2%	\$13,973	26.8%
Net Income	\$ 9,559	19.2%	\$ 12,378	23.8%
Weighted average shares and equivalents: diluted	13,391,030		13,217,634	
Diluted E.P.S.	\$.71		\$.94	
Analysts Consensus Estimate (excluding charge)	\$.73			

KNOW
HOW
good
YOUR
network
CAN BE.™

TOLLGRADE®